



 Read this manual carefully before operating this vehicle.

OWNER'S MANUAL



TZR50

2AS-F819D-E0

 **Read this manual carefully before operating this vehicle. This manual should stay with this vehicle if it is sold.**

Welcome to the Yamaha world of motorcycling!

As the owner of the TZR50, you are benefiting from Yamaha's vast experience and newest technology regarding the design and manufacture of high-quality products, which have earned Yamaha a reputation for dependability.

Please take the time to read this manual thoroughly, so as to enjoy all advantages of your TZR50. The Owner's Manual does not only instruct you in how to operate, inspect and maintain your motorcycle, but also in how to safeguard yourself and others from trouble and injury.

In addition, the many tips given in this manual will help keep your motorcycle in the best possible condition. If you have any further questions, do not hesitate to contact your Yamaha dealer.

The Yamaha team wishes you many safe and pleasant rides. So, remember to put safety first!

Yamaha continually seeks advancements in product design and quality. Therefore, while this manual contains the most current product information available at the time of printing, there may be minor discrepancies between your motorcycle and this manual. If there is any question concerning this manual, please consult a Yamaha dealer.



 **WARNING**

Please read this manual carefully and completely before operating this motorcycle.

IMPORTANT MANUAL INFORMATION

EAU10132

Particularly important information is distinguished in this manual by the following notations:

	This is the safety alert symbol. It is used to alert you to potential personal injury hazards. Obey all safety messages that follow this symbol to avoid possible injury or death.
	A WARNING indicates a hazardous situation which, if not avoided, could result in death or serious injury.
	A NOTICE indicates special precautions that must be taken to avoid damage to the vehicle or other property.
TIP	A TIP provides key information to make procedures easier or clearer.

IMPORTANT MANUAL INFORMATION

EAUS1172

**TZR50
OWNER'S MANUAL
©2012 by MBK INDUSTRIE
1st edition, April 2012
All rights reserved.
Any reprinting or unauthorized use
without the written permission of
MBK INDUSTRIE
is expressly prohibited.
Printed in Netherlands.**

TABLE OF CONTENTS

SAFETY INFORMATION.....1-1

DESCRIPTION.....2-1

Left view3-1

Right view3-1

Controls and instruments3-1

INSTRUMENT AND CONTROL

FUNCTIONS3-1

Main switch/steering lock.....3-1

Indicator and warning lights3-2

Turn signal indicator light3-2

Neutral indicator light3-2

Oil level warning light3-2

Coolant temperature warning
light3-3

Engine trouble warning light3-3

Speedometer unit3-3

Tachometer3-4

Handlebar switches3-4

Pass switch3-5

Dimmer switch3-5

Turn signal switch3-5

Horn switch3-5

Engine stop switch3-5

Start switch3-5

Clutch lever.....3-5

Shift pedal.....3-6

Brake lever.....3-6

Brake pedal.....3-6

Fuel tank cap.....3-7

Fuel3-8

Fuel tank breather/overflow hose.....3-9

Catalytic converter.....3-9

2-stroke engine oil3-10

Fuel cock3-11

Starter (choke) lever3-12

Seat.....3-12

Anti-theft device housing.....3-13

Rear view mirrors.....3-13

Sidestand.....3-14

Ignition circuit cut-off system3-14

FOR YOUR SAFETY –

PRE-OPERATION CHECKS4-1

OPERATION AND IMPORTANT

RIDING POINTS.....5-1

Starting a cold engine5-1

Starting a warm engine5-2

Shifting.....5-2

Tips for reducing fuel
consumption.....5-3

Engine break-in.....5-3

Parking.....5-4

PERIODIC MAINTENANCE AND

ADJUSTMENT6-1

Owner's tool kit.....6-1

Periodic maintenance chart for
the emission control system6-3

General maintenance and
lubrication chart6-4

Removing and installing cowlings
and panels.....6-8

Checking the spark plug6-11

Transmission oil6-13

Coolant6-14

Air filter element.....6-17

Adjusting the carburetor6-17

Adjusting the engine idling
speed.....6-18

Adjusting the throttle grip
free play.....6-18

Tires6-19

Cast wheels6-21

Adjusting the clutch lever
free play.....6-21

Checking the front brake lever
free play.....6-22

Adjusting the brake pedal
free play.....6-22

Adjusting the shift pedal position...6-22

Brake light switches6-23

Checking the front and rear
brake pads6-23

Checking the brake fluid level6-24

Changing the brake fluid6-25

Drive chain slack.....6-25

Cleaning and lubricating the drive
chain.....6-27

TABLE OF CONTENTS

Checking and lubricating the cables.....6-28	Care7-1
Checking and lubricating the throttle grip and cable.....6-28	Storage7-3
Adjusting the Autolube pump.....6-28	
Checking and lubricating the brake and shift pedals.....6-29	SPECIFICATIONS8-1
Checking and lubricating the brake and clutch levers.....6-29	CONSUMER INFORMATION9-1
Checking and lubricating the sidestand.....6-30	Identification numbers9-1
Checking the front fork.....6-31	Vehicle identification number.....9-1
Checking the steering.....6-31	Model label9-1
Checking the wheel bearings6-32	
Battery6-32	
Replacing the fuse.....6-33	
Replacing the headlight bulb.....6-34	
Replacing the tail/brake light bulb6-35	
Replacing a front turn signal light bulb.....6-35	
Replacing a rear turn signal light bulb.....6-36	
Replacing the license plate light bulb.....6-36	
Troubleshooting6-37	
Troubleshooting charts6-38	
MOTORCYCLE CARE AND STORAGE.....7-1	
Matte color caution.....7-1	



SAFETY INFORMATION

EAU10289

Be a Responsible Owner

As the vehicle's owner, you are responsible for the safe and proper operation of your motorcycle.

Motorcycles are single-track vehicles. Their safe use and operation are dependent upon the use of proper riding techniques as well as the expertise of the operator. Every operator should know the following requirements before riding this motorcycle. He or she should:

- Obtain thorough instructions from a competent source on all aspects of motorcycle operation.
- Observe the warnings and maintenance requirements in this Owner's Manual.
- Obtain qualified training in safe and proper riding techniques.
- Obtain professional technical service as indicated in this Owner's Manual and/or when made necessary by mechanical conditions.

Safe Riding

Perform the pre-operation checks

each time you use the vehicle to make sure it is in safe operating condition. Failure to inspect or maintain the vehicle properly increases the possibility of an accident or equipment damage. See page 4-1 for a list of pre-operation checks.

- This motorcycle is designed to carry the operator and a passenger.
- The failure of motorists to detect and recognize motorcycles in traffic is the predominating cause of automobile/motorcycle accidents. Many accidents have been caused by an automobile driver who did not see the motorcycle. Making yourself conspicuous appears to be very effective in reducing the chance of this type of accident.

Therefore:

- Wear a brightly colored jacket.
- Use extra caution when you are approaching and passing through intersections, since intersections are the most likely places for motorcycle accidents to occur.

- Ride where other motorists can see you. Avoid riding in another motorist's blind spot.
- Many accidents involve inexperienced operators. In fact, many operators who have been involved in accidents do not even have a current motorcycle license.
- Make sure that you are qualified and that you only lend your motorcycle to other qualified operators.
- Know your skills and limits. Staying within your limits may help you to avoid an accident.
- We recommend that you practice riding your motorcycle where there is no traffic until you have become thoroughly familiar with the motorcycle and all of its controls.
- Many accidents have been caused by error of the motorcycle operator. A typical error made by the operator is veering wide on a turn due to excessive speed or undercornering (insufficient lean angle for the speed).



- Always obey the speed limit and never travel faster than warranted by road and traffic conditions.
- Always signal before turning or changing lanes. Make sure that other motorists can see you.
- The posture of the operator and passenger is important for proper control.
 - The operator should keep both hands on the handlebar and both feet on the operator footrests during operation to maintain control of the motorcycle.
 - The passenger should always hold onto the operator, the seat strap or grab bar, if equipped, with both hands and keep both feet on the passenger footrests. Never carry a passenger unless he or she can firmly place both feet on the passenger footrests.
- Never ride under the influence of alcohol or other drugs.
- This motorcycle is designed for on-road use only. It is not suitable

for off-road use.

Protective Apparel

The majority of fatalities from motorcycle accidents are the result of head injuries. The use of a safety helmet is the single most critical factor in the prevention or reduction of head injuries.

- Always wear an approved helmet.
- Wear a face shield or goggles. Wind in your unprotected eyes could contribute to an impairment of vision that could delay seeing a hazard.
- The use of a jacket, heavy boots, trousers, gloves, etc., is effective in preventing or reducing abrasions or lacerations.
- Never wear loose-fitting clothes, otherwise they could catch on the control levers, footrests, or wheels and cause injury or an accident.
- Always wear protective clothing that covers your legs, ankles, and feet. The engine or exhaust system become very hot during or

after operation and can cause burns.

- A passenger should also observe the above precautions.

Avoid Carbon Monoxide Poisoning

All engine exhaust contains carbon monoxide, a deadly gas. Breathing carbon monoxide can cause headaches, dizziness, drowsiness, nausea, confusion, and eventually death.

Carbon Monoxide is a colorless, odorless, tasteless gas which may be present even if you do not see or smell any engine exhaust. Deadly levels of carbon monoxide can collect rapidly and you can quickly be overcome and unable to save yourself. Also, deadly levels of carbon monoxide can linger for hours or days in enclosed or poorly ventilated areas. If you experience any symptoms of carbon monoxide poisoning, leave the area immediately, get fresh air, and **SEEK MEDICAL TREATMENT.**

- Do not run engine indoors. Even if you try to ventilate engine exhaust with fans or open windows and doors, carbon monoxi-



SAFETY INFORMATION

de can rapidly reach dangerous levels.

- Do not run engine in poorly ventilated or partially enclosed areas such as barns, garages, or carports.
- Do not run engine outdoors where engine exhaust can be drawn into a building through openings such as windows and doors.

Loading

Adding accessories or cargo to your motorcycle can adversely affect stability and handling if the weight distribution of the motorcycle is changed. To avoid the possibility of an accident, use extreme caution when adding cargo or accessories to your motorcycle. Use extra care when riding a motorcycle that has added cargo or accessories. Here, along with the information about accessories below, are some general guidelines to follow if loading cargo to your motorcycle:

The total weight of the operator, passenger, accessories and cargo must not exceed the maximum load limit.

Operation of an overloaded vehicle could cause an accident.

Maximum load:
196 kg (432 lb)

When loading within this weight limit, keep the following in mind:

- Cargo and accessory weight should be kept as low and close to the motorcycle as possible. Securely pack your heaviest items as close to the center of the vehicle as possible and make sure to distribute the weight as evenly as possible on both sides of the motorcycle to minimize imbalance or instability.
- Shifting weights can create a sudden imbalance. Make sure that accessories and cargo are securely attached to the motorcycle before riding. Check accessory mounts and cargo restraints frequently.
- Properly adjust the suspension for your load (suspension-adjustable models only), and

check the condition and pressure of your tires.

- Never attach any large or heavy items to the handlebar, front fork, or front fender. These items, including such cargo as sleeping bags, duffel bags, or tents, can create unstable handling or a slow steering response.
- **This vehicle is not designed to pull a trailer or to be attached to a sidecar.**

Genuine Yamaha Accessories

Choosing accessories for your vehicle is an important decision. Genuine Yamaha accessories, which are available only from a Yamaha dealer, have been designed, tested, and approved by Yamaha for use on your vehicle. Many companies with no connection to Yamaha manufacture parts and accessories or offer other modifications for Yamaha vehicles. Yamaha is not in a position to test the products that these aftermarket companies produce. Therefore, Yamaha can neither endorse nor recommend the use



of accessories not sold by Yamaha or modifications not specifically recommended by Yamaha, even if sold and installed by a Yamaha dealer.

Aftermarket Parts, Accessories, and Modifications

While you may find aftermarket products similar in design and quality to genuine Yamaha accessories, recognize that some aftermarket accessories or modifications are not suitable because of potential safety hazards to you or others. Installing aftermarket products or having other modifications performed to your vehicle that change any of the vehicle's design or operation characteristics can put you and others at greater risk of serious injury or death. You are responsible for injuries related to changes in the vehicle.

Keep the following guidelines in mind, as well as those provided under "Loading" when mounting accessories.

- Never install accessories or carry cargo that would impair the performance of your motorcycle. Carefully inspect the accessory

before using it to make sure that it does not in any way reduce ground clearance or cornering clearance, limit suspension travel, steering travel or control operation, or obscure lights or reflectors.

- Accessories fitted to the handlebar or the front fork area can create instability due to improper weight distribution or aerodynamic changes. If accessories are added to the handlebar or front fork area, they must be as lightweight as possible and should be kept to a minimum.
- Bulky or large accessories may seriously affect the stability of the motorcycle due to aerodynamic effects. Wind may attempt to lift the motorcycle, or the motorcycle may become unstable in cross winds. These accessories may also cause instability when passing or being passed by large vehicles.
- Certain accessories can displace the operator from his or

her normal riding position. This improper position limits the freedom of movement of the operator and may limit control ability, therefore, such accessories are not recommended.

- Use caution when adding electrical accessories. If electrical accessories exceed the capacity of the motorcycle's electrical system, an electric failure could result, which could cause a dangerous loss of lights or engine power.

Aftermarket Tires and Rims

The tires and rims that came with your motorcycle were designed to match the performance capabilities and to provide the best combination of handling, braking, and comfort. Other tires, rims, sizes, and combinations may not be appropriate. Refer to page 6-19 for tire specifications and more information on replacing your tires.



SAFETY INFORMATION

Transporting the Motorcycle

Be sure to observe following instructions before transporting the motorcycle in another vehicle.

- Remove all loose items from the motorcycle.
 - Check that the fuel cock (if equipped) is in the “OFF” position and that there are no fuel leaks.
 - Point the front wheel straight ahead on the trailer or in the truck bed, and choke it in a rail to prevent movement.
 - Shift the transmission in gear (for models with a manual transmission).
 - Secure the motorcycle with tie-downs or suitable straps that are attached to solid parts of the motorcycle, such as the frame or upper front fork triple clamp (and not, for example, to rubber-mounted handlebars or turn signals, or parts that could break). Choose the location for the straps carefully so the straps will not rub against painted surfaces during transport.
- The suspension should be compressed somewhat by the tie-downs, if possible, so that the motorcycle will not bounce excessively during transport.

Left view

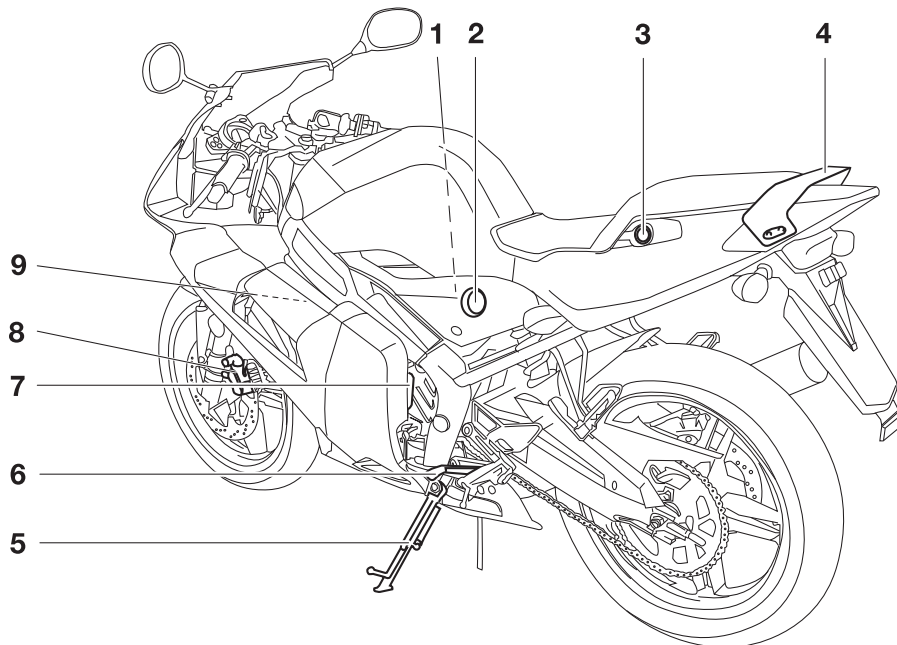

1. Air filter (page 6-17)
2. Fuel cock lever (page 3-11)
3. Seat lock (page 3-12)
4. Grab bar (page 3-12)
5. Sidestand (page 3-14)
6. Shift pedal (page 3-6)
7. Coolant reservoir (page 6-14)
8. Front brake pads (page 6-23)

9. Coolant reservoir cap (page 6-14)

DESCRIPTION

EAU10420

Right view

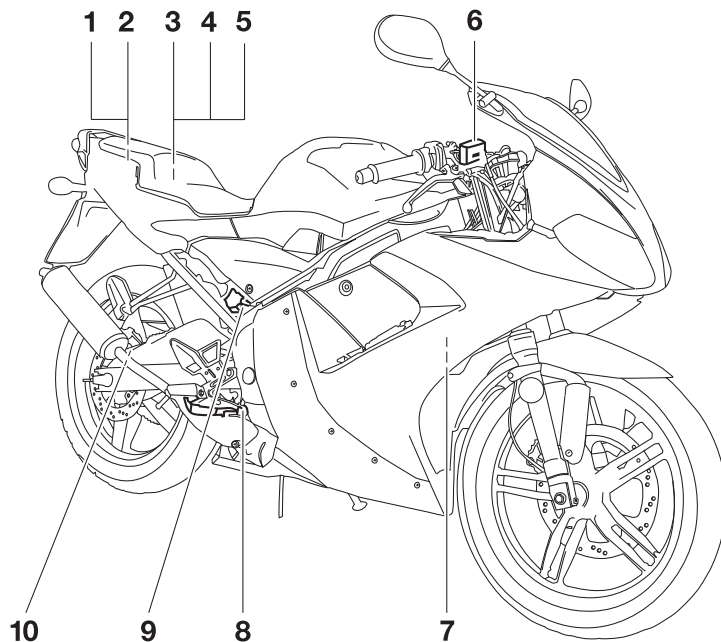

- 1. Anti-theft device housing (page 3-13)
- 2. Owner's tool kit (page 6-1)
- 3. Battery (page 6-32)
- 4. Main fuse (page 6-33)
- 5. 2-stroke engine oil tank cap (page 3-10)
- 6. Front brake fluid reservoir (page 6-24)
- 7. Radiator cap (page 6-14)
- 8. Brake pedal (page 3-6)

- 9. Rear brake fluid reservoir (page 6-24)
- 10. Rear brake pads (page 6-23)

Controls and instruments

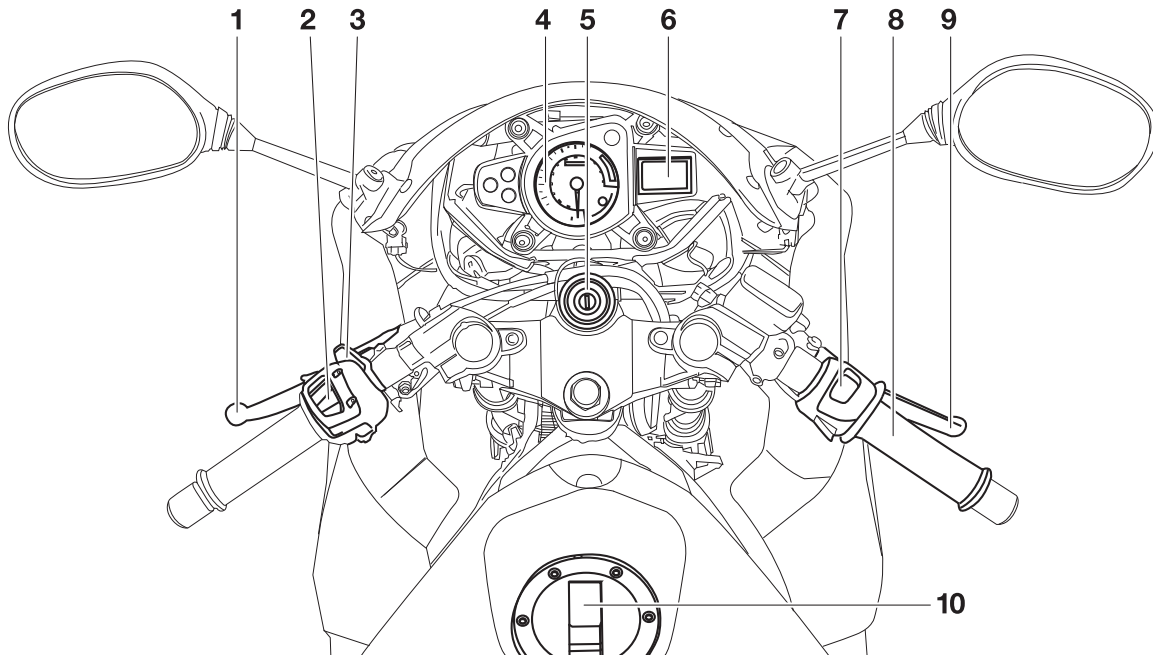

- 1. Clutch lever (page 3-5)
- 2. Left handlebar switches (page 3-4)
- 3. Starter (choke) lever (page 3-12)
- 4. Tachometer (page 3-4)
- 5. Main switch/steering lock (page 3-1)
- 6. Speedometer unit (page 3-3)
- 7. Right handlebar switches (page 3-4)
- 8. Throttle grip (page 6-18)

- 9. Front brake lever (page 3-6)
- 10. Fuel tank cap (page 3-7)

INSTRUMENT AND CONTROL FUNCTIONS

Main switch/steering lock

EAU10460

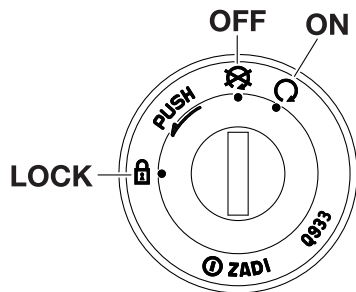

The main switch/steering lock controls the ignition and lighting systems, and is used to lock the steering. The various positions are described below.

ON

EAU10640

All electrical circuits are supplied with power, and the engine can be started. The key cannot be removed.

TIP



The headlight, meter lighting and tail-light come on automatically when the engine is started.

OFF

All electrical systems are off. The key can be removed.

EAU10661

WARNING

Never turn the key to “” or “” while the vehicle is moving. Otherwise the electrical systems will be switched off, which may result in loss of control or an accident.

EWA10061

LOCK

The steering is locked, and all electrical systems are off. The key can be removed.

EAU10683

To lock the steering

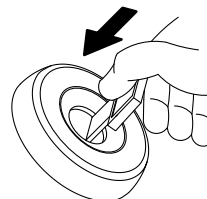

1

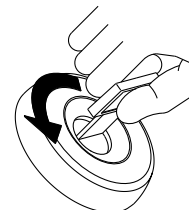

2



1. Push
2. Turn

1. Turn the handlebars all the way to the left.
2. Push the key in from the “” position, and then turn it to “” while still pushing it.
3. Remove the key.

INSTRUMENT AND CONTROL FUNCTIONS

To unlock the steering

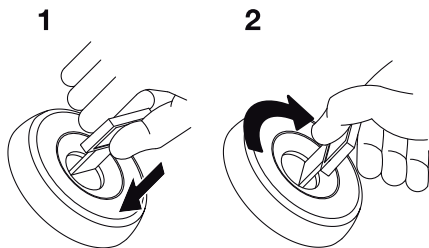

1. Push
2. Turn

Push the key in, and then turn it to “” while still pushing it.

EAU11004

Indicator and warning lights

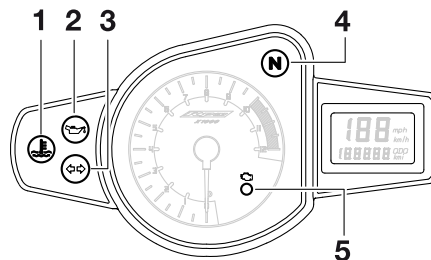

1. Coolant temperature warning light “”
2. Oil level warning light “”
3. Turn signal indicator light “ ”
4. Neutral indicator light “**N**”
5. Engine trouble warning light “”

EAU11020

Turn signal indicator light “ ”

This indicator light flashes when the turn signal switch is pushed to the left or right.

EAU11060

Neutral indicator light “**N**”

This indicator light comes on when the transmission is in the neutral position.

EAU1062

Oil level warning light “”

This warning light comes on when the key is in the “” position or if the oil level in the 2-stroke engine oil tank is low during operation. If the warning light comes on during operation, stop immediately and fill the oil tank with 2-stroke engine oil of either JASO grade “FC” or ISO grades “EG-C” or “EG-D”. The warning light should go off after the 2-stroke engine oil tank has been refilled.

TIP

_____ If the warning light does not come on when the key is in the “” position or does not go off after the 2-stroke engine oil tank has been refilled, have an Yamaha dealer check the electrical circuit. _____

ECA16291

NOTICE

Do not operate the vehicle until you know that the engine oil level is sufficient.

INSTRUMENT AND CONTROL FUNCTIONS

Coolant temperature warning light

EAU11446

“”

This warning light comes on if the engine overheats. If this occurs, stop the engine immediately and allow the engine to cool.

The electrical circuit of the warning light can be checked by turning the key to “”. The warning light should come on for a few seconds, and then go off.

If the warning light does not come on initially when the key is turned to “”, or if the warning light remains on, have a Yamaha dealer check the electrical circuit.

ECA10021

NOTICE

Do not continue to operate the engine if it is overheating.

TIP

- For radiator-fan-equipped vehicles, the radiator fan(s) automatically switch on or off according to the coolant temperature in the radiator.

- If the engine overheats, see page 6-39 for further instructions.

Engine trouble warning light “”

EAUS1540

This warning light flashes if a problem is detected in the electrical circuit monitoring the engine. If this occurs, have a Yamaha dealer check the self-diagnosis system.

The electrical circuit of the warning light can be checked by turning the key to “”. If the warning light does not come on for a few seconds, then go off, have a Yamaha dealer check the electrical circuit.

Speedometer unit

EAU11621

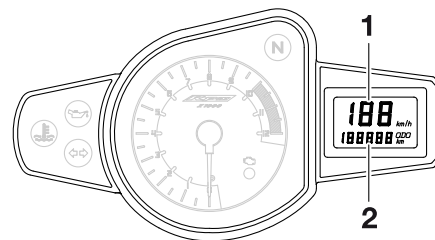

1. Speedometer
2. Odometer

UK ONLY

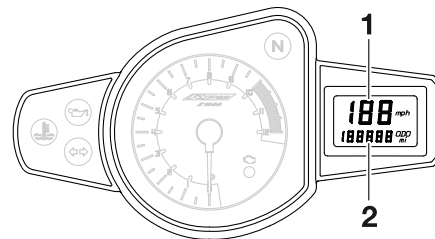

1. Speedometer
2. Odometer

INSTRUMENT AND CONTROL FUNCTIONS

The speedometer unit is equipped with a speedometer and an odometer. The speedometer shows riding speed. The odometer shows the total distance traveled.

EAU11851

Tachometer

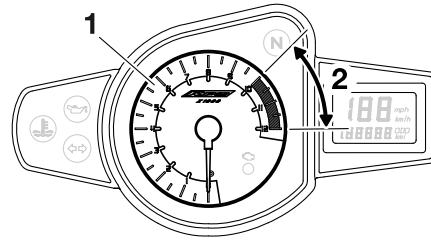

1. Tachometer
2. Tachometer red zone

The electric tachometer allows the rider to monitor the engine speed and keep it within the ideal power range.

ECA10031

NOTICE

Do not operate the engine in the tachometer red zone.

Red zone: 10000 r/min and above

EAU12348

Handlebar switches Left

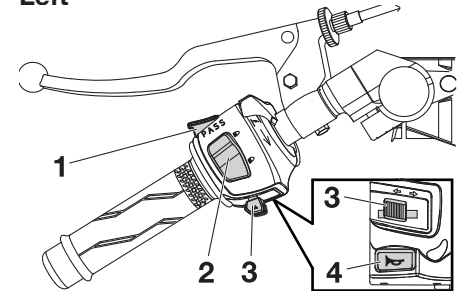

1. Pass switch "PASS"
2. Dimmer switch "☰/☱"
3. Turn signal switch "↔/↔"
4. Horn switch "📢"

Right

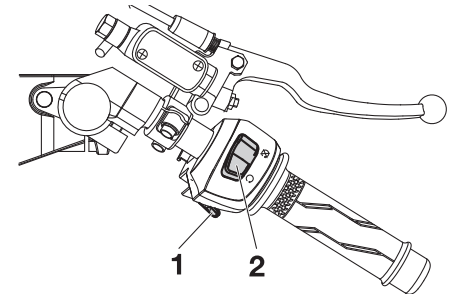

1. Start switch "🌀"
2. Engine stop switch "⊙/⊗"

INSTRUMENT AND CONTROL FUNCTIONS



Pass switch “PASS”

EAU12360

Press this switch to flash the headlight.



Dimmer switch “ / ”

EAU12400

Set this switch to “” for the high beam and to “” for the low beam.

Turn signal switch “ / ”

EAU12460

To signal a right-hand turn, push this switch to “”. To signal a left-hand turn, push this switch to “”. When released, the switch returns to the center position. To cancel the turn signal lights, push the switch in after it has returned to the center position.



Horn switch “”

EAU12500

Press this switch to sound the horn.

Engine stop switch “ / ”

EAU12660

Set this switch to “” before starting the engine. Set this switch to “” to stop the engine in case of an emergency, such as when the vehicle over-

turns or when the throttle cable is stuck.

Start switch “”

EAU12711

Push this switch to crank the engine with the starter. See page 5-1 for starting instructions prior to starting the engine.

Clutch lever

EAU31640

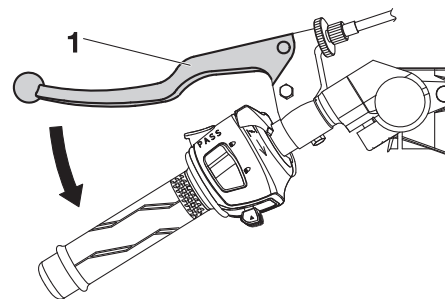

1. Clutch lever

The clutch lever is located at the left handlebar grip. To disengage the clutch, pull the lever toward the handlebar grip. To engage the clutch, release the lever. The lever should be pulled rapidly and released slowly for smooth clutch operation.

The clutch lever is equipped with a clutch switch, which is part of the starting circuit cut-off system. (See page 3-14).

INSTRUMENT AND CONTROL FUNCTIONS

EAU12871

Shift pedal

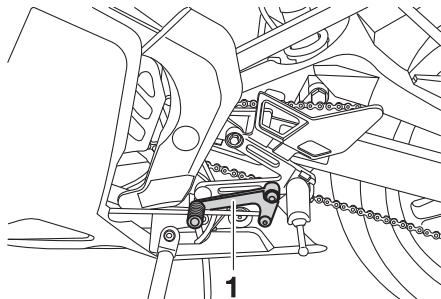

1. Shift pedal

The shift pedal is located on the left side of the motorcycle and is used in combination with the clutch lever when shifting the gears of the 6-speed constant-mesh transmission equipped on this motorcycle.

EAU12890

Brake lever

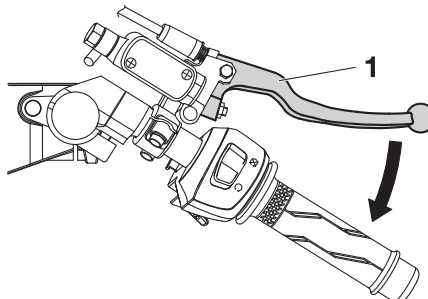

1. Brake lever

The brake lever is located at the right handlebar grip. To apply the front brake, pull the lever toward the handlebar grip.

EAU12941

Brake pedal

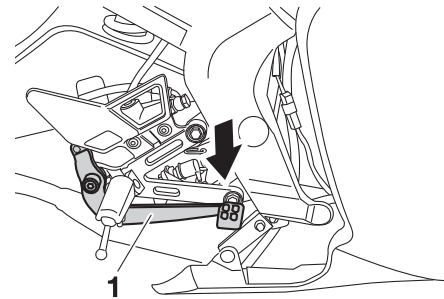

1. Brake pedal

The brake pedal is on the right side of the motorcycle. To apply the rear brake, press down on the brake pedal.

3

INSTRUMENT AND CONTROL FUNCTIONS

EAU13074

EWA11091

Fuel tank cap

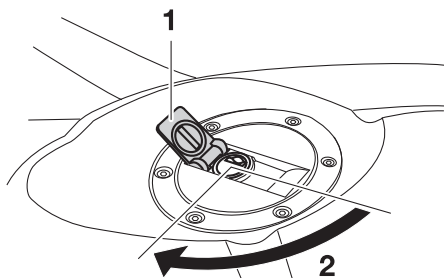

1. Fuel tank cap lock cover
2. Unlock

To open the fuel tank cap

Open the fuel tank cap lock cover, insert the key into the lock, and then turn it 1/4 turn clockwise. The lock will be released and the fuel tank cap can be opened.

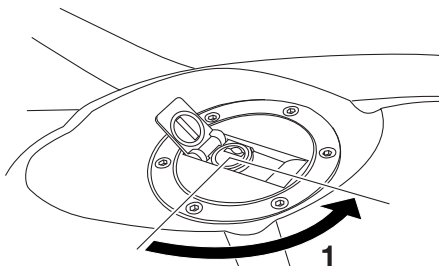

1. Lock

To close the fuel tank cap

1. Push the fuel tank cap into position with the key inserted in the lock.
2. Turn the key counterclockwise to the original position, remove it, and then close the lock cover.

TIP

The fuel tank cap cannot be closed unless the key is in the lock. In addition, the key cannot be removed if the cap is not properly closed and locked.

WARNING

Make sure that the fuel tank cap is properly closed after filling fuel. Leaking fuel is a fire hazard.

INSTRUMENT AND CONTROL FUNCTIONS

EAU13212

Fuel

Make sure there is sufficient gasoline in the tank.

EWA10881

WARNING

Gasoline and gasoline vapors are extremely flammable. To avoid fires and explosions and to reduce the risk of injury when refueling, follow these instructions.

1. Before refueling, turn off the engine and be sure that no one is sitting on the vehicle. Never refuel while smoking, or while in the vicinity of sparks, open flames, or other sources of ignition such as the pilot lights of water heaters and clothes dryers.
2. Do not overfill the fuel tank. Stop filling when the fuel reaches the bottom of the filler tube. Because fuel expands when it heats up, heat from the engine or the sun can cause fuel to spill out of the fuel tank.

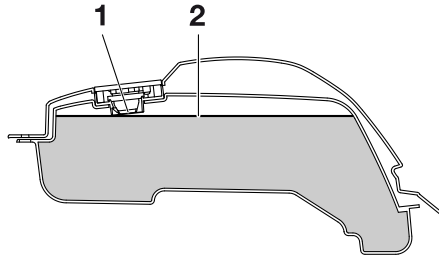

1. Fuel tank filler tube
2. Maximum fuel level

3. Wipe up any spilled fuel immediately. **NOTICE: Immediately wipe off spilled fuel with a clean, dry, soft cloth, since fuel may deteriorate painted surfaces or plastic parts.** [ECA10071]
4. Be sure to securely close the fuel tank cap.

EWA15151

WARNING

Gasoline is poisonous and can cause injury or death. Handle gasoline with care. Never siphon gasoline by mouth. If you should swallow some gasoline or inhale a lot of gasoline

vapor, or get some gasoline in your eyes, see your doctor immediately. If gasoline spills on your skin, wash with soap and water. If gasoline spills on your clothing, change your clothes.

EAU13270

Recommended fuel:
REGULAR UNLEADED
GASOLINE ONLY

Fuel tank capacity:
13.8 L (3.65 US gal, 3.04 Imp.gal)

Fuel reserve amount:
2.2 L (0.58 US gal, 0.48 Imp.gal)

Your Yamaha engine has been designed to use regular unleaded gasoline with a research octane number of 91 or higher. If knocking (or pinging) occurs, use a gasoline of a different brand or premium unleaded fuel. Use of unleaded fuel will extend spark plug life and reduce maintenance costs.

INSTRUMENT AND CONTROL FUNCTIONS

EAUB1300

EAU13433

ECA10701

Fuel tank breather/overflow hose

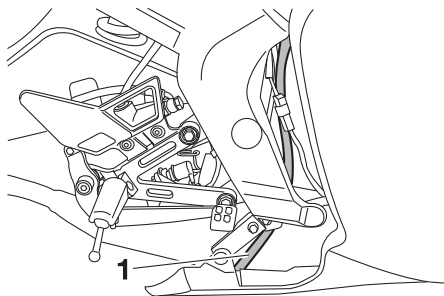

1. Fuel tank breather hose and overflow hose

Before operating the motorcycle:

- Check the fuel tank breather/overflow hose connection.
- Check the fuel tank breather/overflow hose for cracks or damage, and replace it if damaged.
- Make sure that the end of the fuel tank breather/overflow hose is not blocked, and clean it if necessary.
- Make sure that the end of the fuel tank breather/overflow hose is positioned inside of the clamp.

Catalytic converter

This model is equipped with a catalytic converter in the exhaust system.

EWA10862

! WARNING

The exhaust system is hot after operation. To prevent a fire hazard or burns:

- Do not park the vehicle near possible fire hazards such as grass or other materials that easily burn.
- Park the vehicle in a place where pedestrians or children are not likely to touch the hot exhaust system.
- Make sure that the exhaust system has cooled down before doing any maintenance work.
- Do not allow the engine to idle more than a few minutes. Long idling can cause a build-up of heat.

NOTICE

Use only unleaded gasoline. The use of leaded gasoline will cause unrepairable damage to the catalytic converter.

INSTRUMENT AND CONTROL FUNCTIONS

EAUS1550

2-stroke engine oil

Make sure that there is sufficient 2-stroke engine oil in the oil tank. Add the recommended 2-stroke engine oil as necessary.

The 2-stroke engine oil tank is located under the seat. (See page 3-12).

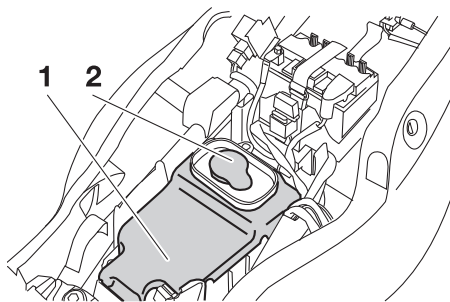

1. 2-stroke engine oil tank
2. 2-stroke engine oil tank cap

1. Remove the 2-stroke engine oil tank cap by pulling it off.

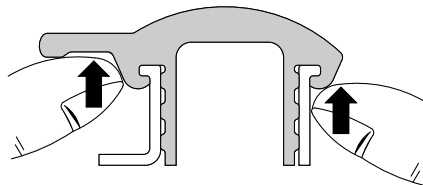

2. Install the 2-stroke engine oil tank cap by pushing it into the oil tank opening.

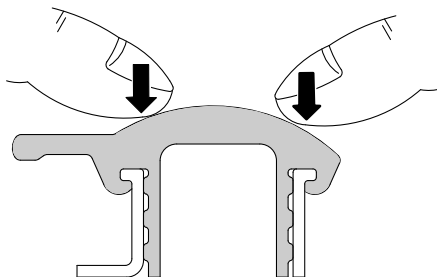

Recommended oil:

See page 8-1

Oil quantity:

1.40 L (1.48 US qt, 1.23 Imp.qt)

3

TIP

Make sure that the 2-stroke engine oil tank cap is properly installed before riding the vehicle.

INSTRUMENT AND CONTROL FUNCTIONS

EAU13561

Fuel cock

The fuel cock supplies fuel from the tank to the carburetor while filtering it also.

The fuel cock has three positions:

3

OFF

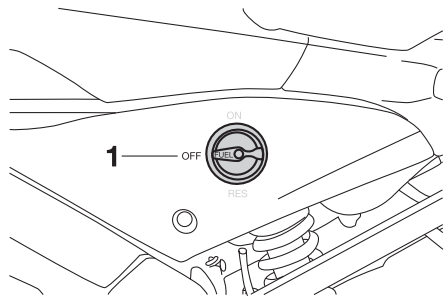

1. Pointed end positioned over “OFF”

With the lever in this position, fuel will not flow. Always return the lever to this position when the engine is not running.

ON

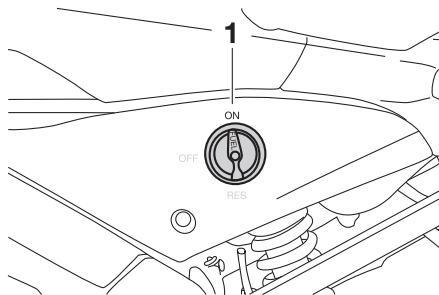

1. Pointed end positioned over “ON”

With the lever in this position, fuel flows to the carburetor. Normal riding is done with the lever in this position.

RES

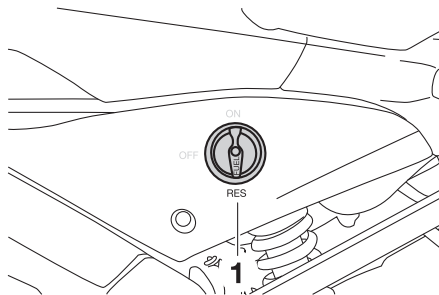

1. Pointed end positioned over “RES”

This indicates reserve. If you run out of fuel while riding, move the lever to this position. Fill the tank at the first opportunity. Be sure to set the lever back to “ON” after refueling!

EAU13590

Starter (choke) lever “”

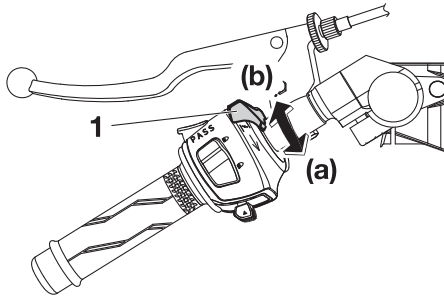

1. Starter (choke) lever

Starting a cold engine requires a richer air-fuel mixture, which is supplied by the starter (choke). Move the lever in direction (a) to turn on the starter (choke). Move the lever in direction (b) to turn off the starter (choke).

EAU13900

Seat

To remove the seat

1. Insert the key into the seat lock, and then turn it as shown.

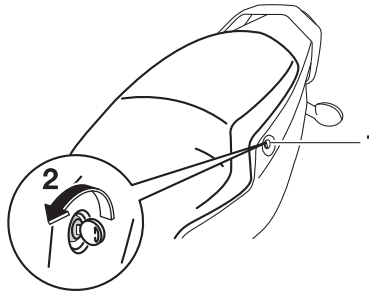

1. Seat lock
2. Open

2. Pull the seat off.

To install the seat

1. Insert the projection on the front of the seat into the seat holder as shown.

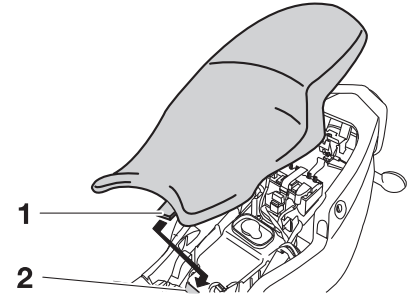

1. Projection
2. Seat holder

2. Push the rear of the seat down to lock it in place.
3. Remove the key.

TIP

Make sure that the seat is properly secured before riding.

INSTRUMENT AND CONTROL FUNCTIONS

EAUM1941

Anti-theft device housing

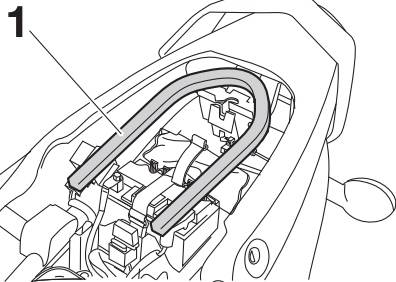

1. U-LOCK bar

The anti-theft device housing, located in the storage compartment under the seat, is designed to hold a genuine Yamaha CYCLELOK. (See page 3-12 for seat opening and closing procedures.) When placing a CYCLELOK in the storage compartment, securely fasten it with the straps. When the CYCLELOK is not in the storage compartment, be sure to secure the straps to prevent losing them.

TIP

Some U-LOCKS cannot fit into the housing due to their size or shape.

EAU39671

Rear view mirrors

The rear view mirrors of this vehicle can be folded forward or backward for parking in narrow spaces. Fold the mirrors back to their original position before riding.

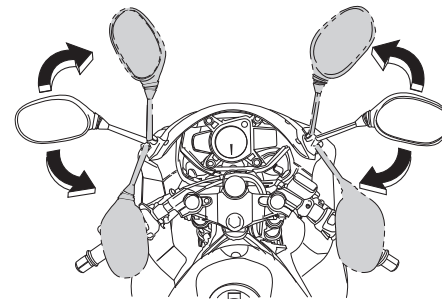

EWA14371

WARNING

Be sure to fold the rear view mirrors back to their original position before riding.

Sidestand

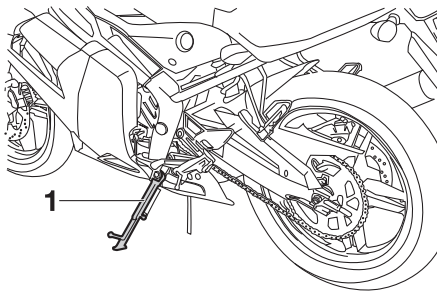

1. Sidestand

The sidestand is located on the left side of the frame. Raise the sidestand or lower it with your foot while holding the vehicle upright.

TIP

The built-in sidestand switch is part of the ignition circuit cut-off system, which cuts the ignition in certain situations. (See the following section for an explanation of the ignition circuit cut-off system.)

WARNING

The vehicle must not be ridden with the sidestand down, or if the sidestand cannot be properly moved up (or does not stay up), otherwise the sidestand could contact the ground and distract the operator, resulting in a possible loss of control. Yamaha's ignition circuit cut-off system has been designed to assist the operator in fulfilling the responsibility of raising the sidestand before starting off. Therefore, check this system regularly and have a Yamaha dealer repair it if it does not function properly.

Ignition circuit cut-off system

The ignition circuit cut-off system (comprising the sidestand switch, clutch switch and neutral switch) has the following functions.

- It prevents starting when the transmission is in gear and the sidestand is up, but the clutch lever is not pulled.
- It prevents starting when the transmission is in gear and the clutch lever is pulled, but the sidestand is still down.
- It cuts the running engine when the transmission is in gear and the sidestand is moved down.

Periodically check the operation of the ignition circuit cut-off system according to the following procedure.

TIP

This check is most reliable if performed with a warmed-up engine.

INSTRUMENT AND CONTROL FUNCTIONS

3

With the engine turned off:

1. Move the sidestand down.
2. Make sure that the engine stop switch is set to “○”.
3. Turn the key “○”.
4. Shift the transmission into the neutral position.
5. Push the start switch.

Does the engine start?

YES NO

With the engine still running:

6. Move the sidestand up.
7. Keep the clutch lever pulled.
8. Shift the transmission into gear.
9. Move the sidestand down.

Does the engine stall?

YES NO

After the engine has stalled:

10. Move the sidestand up.
11. Keep the clutch lever pulled.
12. Push the start switch.

Does the engine start?

YES NO

The system is OK. **The motorcycle can be ridden.**



WARNING

If a malfunction is noted, have a Yamaha dealer check the system before riding.

The neutral switch may not be working correctly.
The motorcycle should not be ridden until checked by a Yamaha dealer.

The sidestand switch may not be working correctly.
The motorcycle should not be ridden until checked by a Yamaha dealer.

The clutch switch may not be working correctly.
The motorcycle should not be ridden until checked by a Yamaha dealer.

FOR YOUR SAFETY – PRE-OPERATION CHECKS

EAU15596

Inspect your vehicle each time you use it to make sure the vehicle is in safe operating condition. Always follow the inspection and maintenance procedures and schedules described in the Owner's Manual.

EWA11151

WARNING

Failure to inspect or maintain the vehicle properly increases the possibility of an accident or equipment damage. Do not operate the vehicle if you find any problem. If a problem cannot be corrected by the procedures provided in this manual, have the vehicle inspected by a Yamaha dealer.

Before using this vehicle, check the following points:

ITEM	CHECKS	PAGE
Fuel	<ul style="list-style-type: none">• Check fuel level in fuel tank.• Refuel if necessary.• Check fuel line for leakage.	3-8
2-stroke engine oil	<ul style="list-style-type: none">• Check oil level in oil tank.• If necessary, add recommended oil to specified level.• Check vehicle for oil leakage.	3-10
Transmission oil	<ul style="list-style-type: none">• Check oil level in transmission case.• If necessary, add recommended oil to specified level.	6-13
Coolant	<ul style="list-style-type: none">• Check coolant level in reservoir.• If necessary, add recommended coolant to specified level.• Check cooling system for leakage.	6-14
Front brake	<ul style="list-style-type: none">• Check operation.• If soft or spongy, have Yamaha dealer bleed hydraulic system.• Check brake pads for wear.• Replace if necessary.• Check fluid level in reservoir.• If necessary, add recommended brake fluid to specified level.• Check hydraulic system for leakage.	6-23, 6-24

FOR YOUR SAFETY – PRE-OPERATION CHECKS

ITEM	CHECKS	PAGE
Rear brake	<ul style="list-style-type: none"> • Check operation. • If soft or spongy, have Yamaha dealer bleed hydraulic system. • Check brake pads for wear. • Replace if necessary. • Check fluid level in reservoir. • If necessary, add recommended brake fluid to specified level. • Check hydraulic system for leakage. 	6-23, 6-24
Clutch	<ul style="list-style-type: none"> • Check operation. • Lubricate cable if necessary. • Check lever free play. • Adjust if necessary. 	6-21
Throttle grip	<ul style="list-style-type: none"> • Make sure that operation is smooth. • Check throttle grip free play. • If necessary, have Yamaha dealer adjust throttle grip free play and lubricate cable and grip housing. 	6-18, 6-28
Control cables	<ul style="list-style-type: none"> • Make sure that operation is smooth. • Lubricate if necessary. 	6-28
Drive chain	<ul style="list-style-type: none"> • Check chain slack. • Adjust if necessary. • Check chain condition. • Lubricate if necessary. 	6-25, 6-27
Wheels and tires	<ul style="list-style-type: none"> • Check for damage. • Check tire condition and tread depth. • Check air pressure. • Correct if necessary. 	6-19, 6-21
Shift pedal	<ul style="list-style-type: none"> • Make sure that operation is smooth. • Correct if necessary. 	6-22, 6-29
Brake pedal	<ul style="list-style-type: none"> • Make sure that operation is smooth. • Lubricate pedal pivoting point if necessary. 	6-29
Brake and clutch levers	<ul style="list-style-type: none"> • Make sure that operation is smooth. • Lubricate lever pivoting points if necessary. 	6-29
Sidestand	<ul style="list-style-type: none"> • Make sure that operation is smooth. • Lubricate pivot if necessary. 	6-30

FOR YOUR SAFETY – PRE-OPERATION CHECKS

ITEM	CHECKS	PAGE
Chassis fasteners	<ul style="list-style-type: none">• Make sure that all nuts, bolts and screws are properly tightened.• Tighten if necessary.	—
Instruments, lights, signals and switches	<ul style="list-style-type: none">• Check operation.• Correct if necessary.	—
Engine stop switch	<ul style="list-style-type: none">• Check operation.	3-4
Sidestand switch	<ul style="list-style-type: none">• Check operation of ignition circuit cut-off system.• If system is not working correctly, have Yamaha dealer check vehicle.	3-14

OPERATION AND IMPORTANT RIDING POINTS

EAU15951

Read the Owner's Manual carefully to become familiar with all controls. If there is a control or function you do not understand, ask your Yamaha dealer.

EWA10271

WARNING

Failure to familiarize yourself with the controls can lead to loss of control, which could cause an accident or injury.

EAU16055

Starting a cold engine

In order for the ignition circuit cut-off system to enable starting, one of the following conditions must be met:

- The transmission is in the neutral position.
- The transmission is in gear with the clutch lever pulled and the sidestand up.

See page 3-14 for more information.

1. Turn the fuel cock lever to "ON".
2. Turn the key to "⊖" and make sure that the engine stop switch is set to "⊖".
3. Shift the transmission into the neutral position. The neutral indicator light should come on. If not, ask a Yamaha dealer to check the electrical circuit.
4. Turn the starter (choke) on and completely close the throttle. (See page 3-12).
5. Start the engine by pushing the start switch.

If the engine fails to start, release the start switch, wait a few seconds, and then try again. Each starting attempt should be

as short as possible to preserve the battery. Do not crank the engine more than 10 seconds on any one attempt.

6. After starting the engine, move the starter (choke) back halfway.
7. When the engine is warm, turn the starter (choke) off.

TIP

The engine is warm when it responds quickly to the throttle with the starter (choke) turned off.

ECA11042

NOTICE

For maximum engine life, never accelerate hard when the engine is cold!

OPERATION AND IMPORTANT RIDING POINTS

EAU16640

Starting a warm engine

Follow the same procedure as for starting a cold engine with the exception that the starter (choke) is not required when the engine is warm.

EAU16671

Shifting

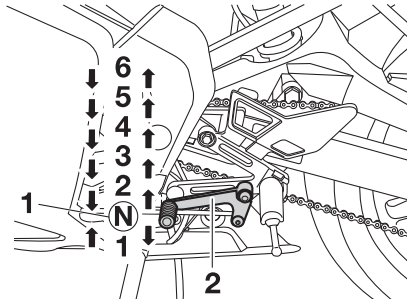

1. Neutral position
2. Shift pedal

Shifting gears lets you control the amount of engine power available for starting off, accelerating, climbing hills, etc.

The gear positions are shown in the illustration.

TIP

To shift the transmission into the neutral position, press the shift pedal down repeatedly until it reaches the end of its travel, and then slightly raise it.

ECA10260

NOTICE

- Even with the transmission in the neutral position, do not coast for long periods of time with the engine off, and do not tow the motorcycle for long distances. The transmission is properly lubricated only when the engine is running. Inadequate lubrication may damage the transmission.
- Always use the clutch while changing gears to avoid damaging the engine, transmission, and drive train, which are not designed to withstand the shock of forced shifting.

OPERATION AND IMPORTANT RIDING POINTS

5

EAU16800

Tips for reducing fuel consumption

Fuel consumption depends largely on your riding style. Consider the following tips to reduce fuel consumption:

- Turn the starter (choke) off as soon as possible.
- Shift up swiftly, and avoid high engine speeds during acceleration.
- Do not rev the engine while shifting down, and avoid high engine speeds with no load on the engine.
- Turn the engine off instead of letting it idle for an extended length of time (e.g., in traffic jams, at traffic lights or at railroad crossings).

EAU16830

Engine break-in

There is never a more important period in the life of your engine than the period between 0 and 1000 km (600 mi). For this reason, you should read the following material carefully. Since the engine is brand new, do not put an excessive load on it for the first 1000 km (600 mi). The various parts in the engine wear and polish themselves to the correct operating clearances. During this period, prolonged full-throttle operation or any condition that might result in engine overheating must be avoided.

EAUS1560

0–500 km (0–300 mi)

- Avoid prolonged operation above 4000 r/min.
- After every hour of operation, stop the engine, and then let it cool for five to ten minutes.
- Vary the engine speed from time to time. Do not operate the engine at one set throttle position.

500–1000 km (300–600 mi)

- Avoid prolonged operation above 6000 r/min.
- Rev the engine freely through the gears, but do not use full throttle at any time. **NOTICE: After 1000 km (600 mi) of operation, the transmission oil must be changed.** [ECA10370]

1000 km (600 mi) and beyond

- The vehicle can now be operated normally.

ECA10310

NOTICE

- Keep the engine speed out of the tachometer red zone.
 - If any engine trouble should occur during the engine break-in period, immediately have a Yamaha dealer check the vehicle.
-

EAU17171

Parking

When parking, stop the engine, remove the key from the main switch, and then turn the fuel cock lever to “OFF”.

EWA10311

WARNING

- Since the engine and exhaust system can become very hot, park in a place where pedestrians or children are not likely to touch them and be burned.
 - Do not park on a slope or on soft ground, otherwise the vehicle may overturn, increasing the risk of a fuel leak and fire.
 - Do not park near grass or other flammable materials which might catch fire.
-

PERIODIC MAINTENANCE AND ADJUSTMENT

EAU17244

Periodic inspection, adjustment, and lubrication will keep your vehicle in the safest and most efficient condition possible. Safety is an obligation of the vehicle owner/operator. The most important points of vehicle inspection, adjustment, and lubrication are explained on the following pages. The intervals given in the periodic maintenance charts should be simply considered as a general guide under normal riding conditions. However, depending on the weather, terrain, geographical location, and individual use, the maintenance intervals may need to be shortened.

EWA15122

⚠ WARNING

Turn off the engine when performing maintenance unless otherwise specified.

- A running engine has moving parts that can catch on body parts or clothing and electrical parts that can cause shocks or fires.
- Running the engine while servicing can lead to eye injury, burns, fire, or carbon monoxide poisoning – possibly leading to death. See page 1-1 for more information about carbon monoxide.

EWA10321

⚠ WARNING

Failure to properly maintain the vehicle or performing maintenance activities incorrectly may increase your risk of injury or death during service or while using the vehicle. If you are not familiar with vehicle service, have a Yamaha dealer perform service.

EWA15460

⚠ WARNING

Brake discs, calipers, drums, and linings can become very hot during use. To avoid possible burns, let brake components cool before touching them.

EAU17521

Owner's tool kit

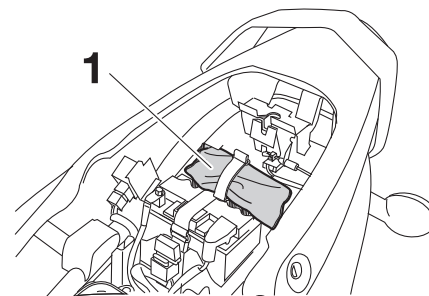

1. Owner's tool kit

The owner's tool kit is located inside the storage compartment under the seat. (See page 3-12).

The service information included in this manual and the tools provided in the owner's tool kit are intended to assist you in the performance of preventive maintenance and minor repairs. However, additional tools such as a torque wrench may be necessary to perform certain maintenance work correctly.

PERIODIC MAINTENANCE AND ADJUSTMENT

TIP

If you do not have the tools or experience required for a particular job, have a Yamaha dealer perform it for you.

PERIODIC MAINTENANCE AND ADJUSTMENT

EAU46871

TIP

- The annual checks must be performed every year, except if a kilometer-based maintenance, or for the UK, a mileage-based maintenance, is performed instead.
- From 30000 km (17500 mi), repeat the maintenance intervals starting from 6000 km (3500 mi).
- Items marked with an asterisk should be performed by a Yamaha dealer as they require special tools, data and technical skills.

EAU46920

Periodic maintenance chart for the emission control system

NO.	ITEM	CHECK OR MAINTENANCE JOB	ODOMETER READING					ANNUAL CHECK
			1000 km (600 mi)	6000 km (3500 mi)	12000 km (7000 mi)	18000 km (10500 mi)	24000 km (14000 mi)	
1	* Fuel line	<ul style="list-style-type: none"> • Check fuel hoses for cracks or damage. 		√	√	√	√	√
2	Spark plug	<ul style="list-style-type: none"> • Replace. 		√	√	√	√	√
3	* Carburetor	<ul style="list-style-type: none"> • Check starter (choke) operation. • Adjust engine idling speed. 	√	√	√	√	√	√
4	* Air induction system	<ul style="list-style-type: none"> • Check the air cut-off valve, reed valve, and hose for damage. • Replace any damaged parts if necessary. 		√	√	√	√	√

PERIODIC MAINTENANCE AND ADJUSTMENT

EAU17717

General maintenance and lubrication chart

NO.	ITEM	CHECK OR MAINTENANCE JOB	ODOMETER READING					ANNUAL CHECK
			1000 km (600 mi)	6000 km (3500 mi)	12000 km (7000 mi)	18000 km (10500 mi)	24000 km (14000 mi)	
1	* Air filter element	• Clean.		√		√		
		• Replace.			√		√	
2	Clutch	• Check operation. • Adjust.	√	√	√	√	√	
3	* Front brake	• Check operation, fluid level and vehicle for fluid leakage.	√	√	√	√	√	√
		• Replace brake pads.	Whenever worn to the limit					
4	* Rear brake	• Check operation, fluid level and vehicle for fluid leakage.	√	√	√	√	√	√
		• Replace brake pads.	Whenever worn to the limit					
5	* Brake hose	• Check for cracks or damage. • Check for correct routing and clamping.		√	√	√	√	√
		• Replace.	Every 4 years					
6	* Wheels	• Check runout and for damage.		√	√	√	√	
7	* Tires	• Check tread depth and for damage. • Replace if necessary. • Check air pressure. • Correct if necessary.		√	√	√	√	√
8	* Wheel bearings	• Check bearing for looseness or damage.		√	√	√	√	

PERIODIC MAINTENANCE AND ADJUSTMENT

NO.	ITEM	CHECK OR MAINTENANCE JOB	ODOMETER READING					ANNUAL CHECK
			1000 km (600 mi)	6000 km (3500 mi)	12000 km (7000 mi)	18000 km (10500 mi)	24000 km (14000 mi)	
9	* Swingarm	<ul style="list-style-type: none"> Check operation and for excessive play. 		✓	✓	✓	✓	
		<ul style="list-style-type: none"> Lubricate with lithium-soap-based grease. 	Every 24000 km (14000 mi)					
10	Drive chain	<ul style="list-style-type: none"> Check chain slack, alignment and condition. Adjust and lubricate chain with a special O-ring chain lubricant thoroughly. 	Every 500 km (300 mi) and after washing the motorcycle, riding in the rain or riding in wet areas					
11	* Steering bearings	<ul style="list-style-type: none"> Check bearing play and steering for roughness. 	✓	✓	✓	✓	✓	
		<ul style="list-style-type: none"> Lubricate with lithium-soap-based grease. 	Every 50000 km (30000 mi)					
12	* Chassis fasteners	<ul style="list-style-type: none"> Make sure that all nuts, bolts and screws are properly tightened. 		✓	✓	✓	✓	✓
13	Brake lever pivot shaft	<ul style="list-style-type: none"> Lubricate with silicone grease. 		✓	✓	✓	✓	✓
14	Brake pedal pivot shaft	<ul style="list-style-type: none"> Lubricate with lithium-soap-based grease. 		✓	✓	✓	✓	✓
15	Clutch lever pivot shaft	<ul style="list-style-type: none"> Lubricate with lithium-soap-based grease. 		✓	✓	✓	✓	✓
16	Shift pedal pivot shaft	<ul style="list-style-type: none"> Lubricate with lithium-soap-based grease. 		✓	✓	✓	✓	✓
17	Sidestand	<ul style="list-style-type: none"> Check operation. Lubricate with lithium-soap-based grease. 		✓	✓	✓	✓	✓
18	* Sidestand switch	<ul style="list-style-type: none"> Check operation. 	✓	✓	✓	✓	✓	✓

PERIODIC MAINTENANCE AND ADJUSTMENT

NO.	ITEM	CHECK OR MAINTENANCE JOB	ODOMETER READING					ANNUAL CHECK
			1000 km (600 mi)	6000 km (3500 mi)	12000 km (7000 mi)	18000 km (10500 mi)	24000 km (14000 mi)	
19	* Front fork	<ul style="list-style-type: none"> • Check operation and for oil leakage. 		√	√	√	√	
20	* Rear suspension relay arm and connecting arm pivoting points	<ul style="list-style-type: none"> • Check operation. 		√	√	√	√	
		<ul style="list-style-type: none"> • Lubricate with lithium-soap-based grease. 			√		√	
21	* Autolube pump	<ul style="list-style-type: none"> • Check operation. • Bleed if necessary. 	√		√		√	√
22	Transmission oil	<ul style="list-style-type: none"> • Check oil level. 	√	√	√	√	√	√
		<ul style="list-style-type: none"> • Change. 	√		√		√	
23	* Front and rear brake switches	<ul style="list-style-type: none"> • Check operation. 	√	√	√	√	√	√
24	Moving parts and cables	<ul style="list-style-type: none"> • Lubricate. 		√	√	√	√	√
25	* Throttle grip	<ul style="list-style-type: none"> • Check operation. • Check throttle grip free play, and adjust if necessary. • Lubricate cable and grip housing. 		√	√	√	√	√
26	* Lights, signals and switches	<ul style="list-style-type: none"> • Check operation. • Adjust headlight beam. 	√	√	√	√	√	√

PERIODIC MAINTENANCE AND ADJUSTMENT

EAU18670

TIP

- The air filter needs more frequent service if you are riding in unusually wet or dusty areas.
 - Hydraulic brake service
 - Regularly check and, if necessary, correct the brake fluid level.
 - Every two years replace the internal components of the brake master cylinders and calipers, and change the brake fluid.
 - Replace the brake hoses every four years and if cracked or damaged.
-

PERIODIC MAINTENANCE AND ADJUSTMENT

EAU18712

Removing and installing cowlings and panels

The cowlings and panels shown need to be removed to perform some of the maintenance jobs described in this chapter. Refer to this section each time a cowling or panel needs to be removed and installed.

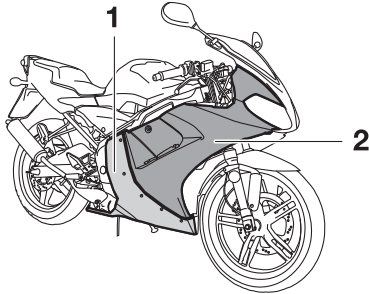

1. Cowling A
2. Cowling C

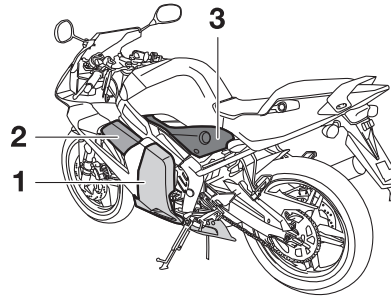

1. Cowling B
2. Panel A
3. Panel B

Cowling A

To remove the cowling

1. Remove the bolt and the screws.

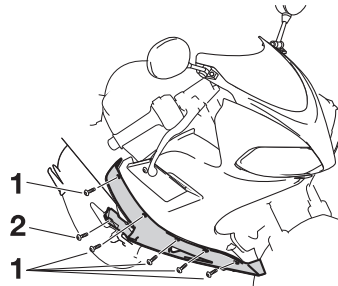

1. Screw
2. Bolt

EAUS2080

2. Pull the cowling down slightly, and then pull it outward as shown.

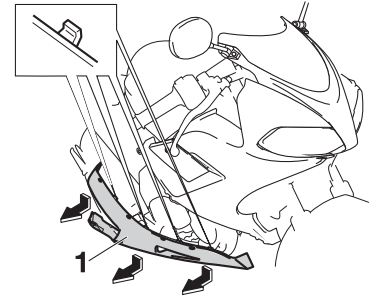

1. Cowling A

To install the cowling

Insert the tabs on the cowling into the slots as shown, and then install the bolt and the screws.



1. Tab

PERIODIC MAINTENANCE AND ADJUSTMENT

EAUS2090

Cowling B

To remove the cowling

1. Remove cowling A.
2. Remove the bolt and the screws.

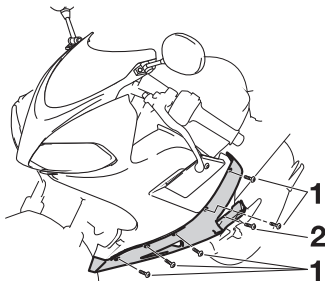

- 6**
1. Screw
 2. Bolt

3. Pull the cowling down slightly, and then pull it outward as shown.

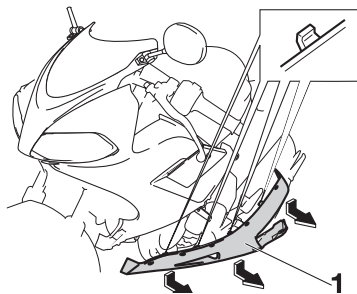

1. Cowling B

To install the cowling

1. Insert the tabs on the cowling into the slots as shown, and then install the bolt and the screws.



1. Tab

2. Install cowling A.

EAUS2100

Cowling C

To remove the cowling

1. Remove cowlings A and B. (See page 6-8).
2. Remove the screw shown.

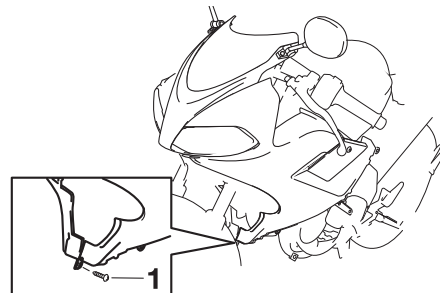

1. Screw

3. Remove the bolts and screws shown, and then take the cowling off.

PERIODIC MAINTENANCE AND ADJUSTMENT

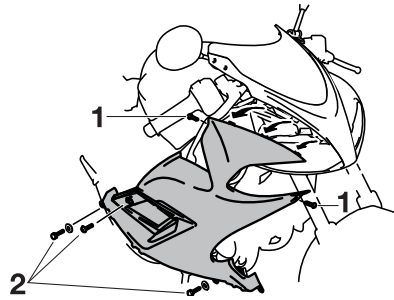

1. Screw
2. Bolt

To install the cowling

1. Insert the tabs on the cowling into the slots as shown, and then install the bolts and screws.

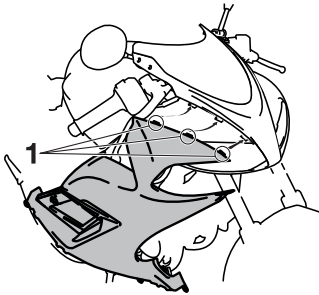

1. Tab

2. Install the screw removed in step 2.
3. Install cowlings B and A.

Panel A

To remove the panel

1. Remove the bolt.

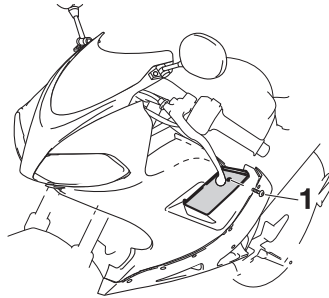

1. Panel mounting bolt

2. Pull the rear of the panel out, and then slide the panel forward to release it in the front.

EAU19161

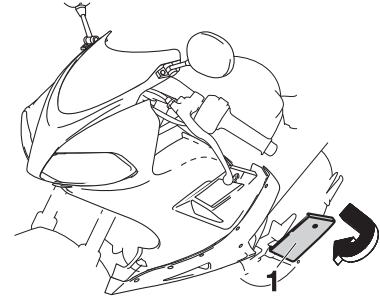

1. Panel A

To install the panel

1. Secure the front of the panel, and then push the rear of the panel in.

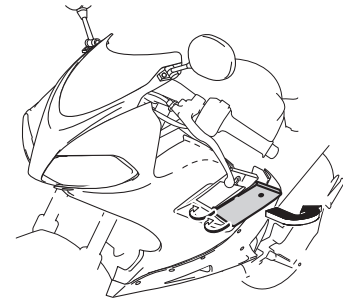

2. Install the bolt.

PERIODIC MAINTENANCE AND ADJUSTMENT

EAUS2110

EAUS1580

Panel B

To remove the panel

1. Turn the fuel cock lever to the off position. (See page 3-11).
2. Remove the fuel cock lever screw, the fuel cock lever and the panel screw, and then take the panel off as shown.

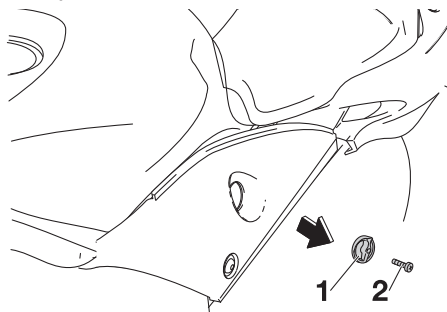

1. Fuel cock lever
2. Screw

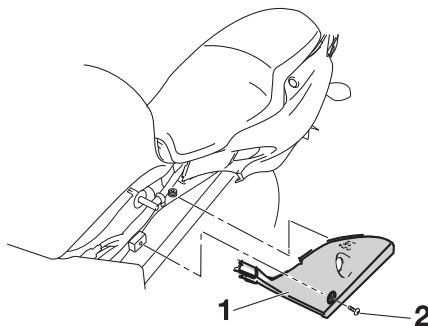

1. Panel B
2. Panel mounting bolt

To install the panel

1. Place the panel in the original position by pushing it.
2. Install the fuel cock lever, the fuel cock lever screw and the panel screw.

Checking the spark plug

The spark plug is an important engine component, which is easy to check. Since heat and deposits will cause any spark plug to slowly erode, the spark plug should be removed and checked in accordance with the periodic maintenance and lubrication chart. In addition, the condition of the spark plug can reveal the condition of the engine.

To remove the spark plug

1. Remove panel A. (See page 6-8).
2. Remove the spark plug cap.

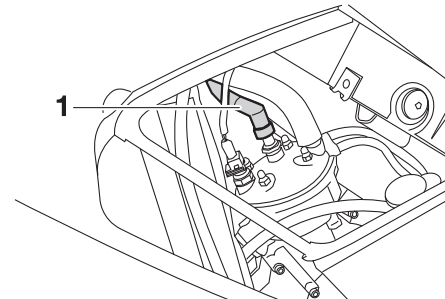

1. Spark plug cap

PERIODIC MAINTENANCE AND ADJUSTMENT

3. Remove the spark plug as shown, using the spark plug wrench, which is located in the storage compartment. (See page 6-1).

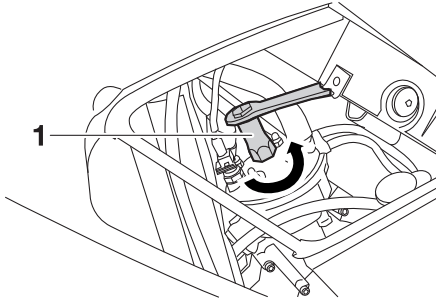

1. Spark plug wrench

To check the spark plug

1. Check that the porcelain insulator around the center electrode of the spark plug is a medium-to-light tan (the ideal color when the vehicle is ridden normally).

TIP

If the spark plug shows a distinctly different color, the engine could be operating improperly. Do not attempt to diagnose such problems yourself.

Instead, have a Yamaha dealer check the vehicle.

2. Check the spark plug for electrode erosion and excessive carbon or other deposits, and replace it if necessary.

Specified spark plug:
NGK / BR9 ES

To install the spark plug

1. Measure the spark plug gap with a wire thickness gauge and, if necessary, adjust the gap to specification.

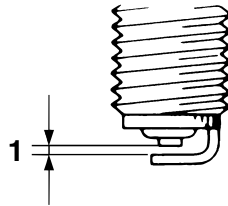

1. Spark plug gap

Spark plug gap:

0.6–0.7 mm (0.024–0.028 in)

2. Clean the surface of the spark plug gasket and its mating surface, and then wipe off any grime from the spark plug threads.
3. Install the spark plug with the spark plug wrench, and then tighten it to the specified torque.

Tightening torque:

Spark plug:
22.5 Nm (2.2 m•kgf, 16.3 ft•lbf)

TIP

If a torque wrench is not available when installing a spark plug, a good estimate of the correct torque is 1/4–1/2 turn past finger tight. However, the spark plug should be tightened to the specified torque as soon as possible.

4. Install the spark plug cap.
5. Install the panel.

PERIODIC MAINTENANCE AND ADJUSTMENT

EAUS1591

Transmission oil

The transmission oil level should be checked before each ride. In addition, the oil must be changed at the intervals specified in the periodic maintenance and lubrication chart.

To check the transmission oil level

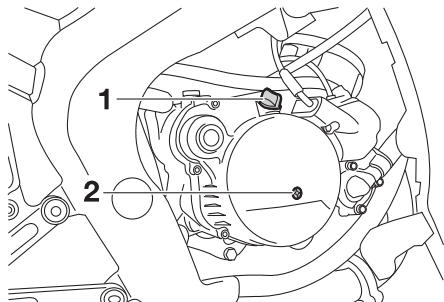

1. Transmission oil filler cap
2. Transmission oil check bolt

1. Remove cowling A. (See page 6-8).
2. Place the vehicle on a level surface and hold it in an upright position.

TIP _____
Make sure that the vehicle is positioned straight up when checking the oil level. A slight tilt to the side can result in a false reading.

3. Remove the oil check bolt, and then check the oil level.

TIP _____
The oil should be at the brim of the check hole.

4. If the oil is below the brim of the check hole, remove the oil filler cap, add sufficient oil of the recommended type to raise it to the correct level, and then install the oil filler cap.
5. Install the oil check bolt, and then tighten it to the specified torque.

Tightening torque:

Oil check bolt:
6 Nm (0.6 m•kgf, 4.3 ft•lbf)

To change the transmission oil

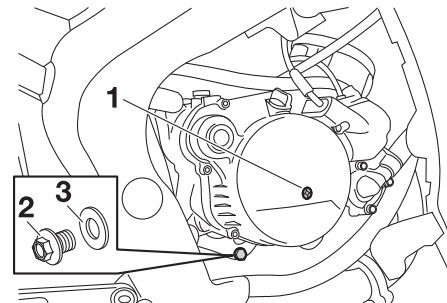

1. Transmission oil check bolt
2. Transmission oil drain bolt
3. Washer

1. Place an oil pan under the transmission oil case to collect the used oil.
2. Remove the drain bolt and the oil check bolt to drain the oil.
3. Install the drain bolt and the check bolt, and then tighten them to the specified torques.

PERIODIC MAINTENANCE AND ADJUSTMENT

Tightening torque:

Transmission oil drain bolt:

17.5 Nm (1.7 m•kgf, 12.7 ft•lbf)

Oil check bolt:

6 Nm (0.6 m•kgf, 4.3 ft•lbf)

4. Remove the oil filler cap, refill with the specified amount of the recommended transmission oil, and then install and tighten the oil filler cap. **NOTICE: Make sure that no foreign material enters the transmission case.** [ECAM1021]

Recommended transmission oil:

See page 8-1

Oil change quantity:

0.75 L (0.79 US qt, 0.66 Imp.qt)

5. Start the engine and let it idle for several minutes while checking the transmission oil case for oil leakage. If oil is leaking, immediately turn the engine off and check for the cause.

EAU20070

Coolant

The coolant level should be checked before each ride. In addition, the coolant must be changed at the intervals specified in the periodic maintenance and lubrication chart.

EAU39087

To check the coolant level

1. Place the vehicle on a level surface and hold it in an upright position.

TIP

- The coolant level must be checked on a cold engine since the level varies with engine temperature.
- Make sure that the vehicle is positioned straight up when checking the coolant level. A slight tilt to the side can result in a false reading.

2. Check the coolant level in the coolant reservoir.

TIP

The coolant should be between the minimum and maximum level marks.

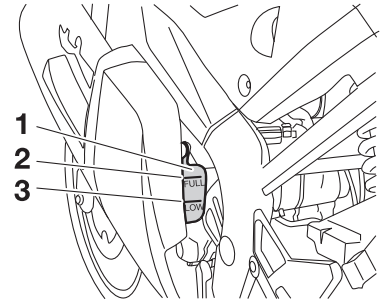

1. Coolant reservoir
2. Maximum level mark
3. Minimum level mark

3. If the coolant is at or below the minimum level mark, remove panel A to access the coolant reservoir. (See page 6-8).
4. Remove the coolant reservoir cap, add coolant to the maximum level mark, and then install the reservoir cap. **WARNING! Remove only the coolant reservoir cap. Never attempt to remove the radiator cap when the engine is hot.** [EWA15161]

PERIODIC MAINTENANCE AND ADJUSTMENT

NOTICE: If coolant is not available, use distilled water or soft tap water instead. Do not use hard water or salt water since it is harmful to the engine. If water has been used instead of coolant, replace it with coolant as soon as possible, otherwise the cooling system will not be protected against frost and corrosion. If water has been added to the coolant, have a Yamaha dealer check the anti-freeze content of the coolant as soon as possible, otherwise the effectiveness of the coolant will be reduced. [ECA10472]

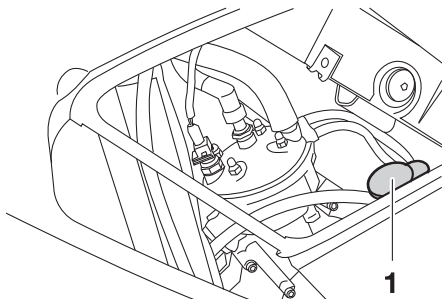

1. Coolant reservoir cap

Coolant reservoir capacity (up to the maximum level mark):

0.29 L (0.31 US qt, 0.26 Imp.qt)

5. Install the panel.

EAUS2070

To change the coolant

1. Place the vehicle on a level surface and let the engine cool if necessary.
2. Remove cowlings A, B and C and panel A. (See page 6-8).
3. Place a container under the engine to collect the used coolant.
4. Remove the radiator cap retaining bolt, radiator cap retainer and radiator cap. **WARNING! Never attempt to remove the radiator cap when the engine is hot.** [EWA10381]

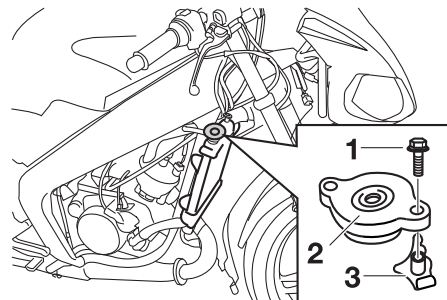

1. Radiator cap retaining bolt
2. Radiator cap
3. Radiator cap retainer

5. Remove the coolant drain bolt and its gasket to drain the cooling system.

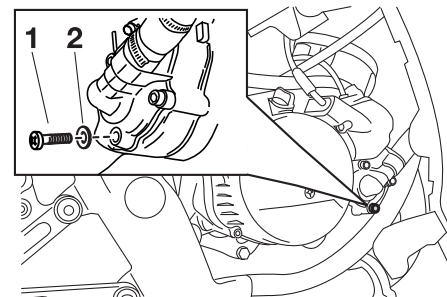

1. Coolant drain bolt
2. Gasket

PERIODIC MAINTENANCE AND ADJUSTMENT

6. Remove the coolant reservoir cap.

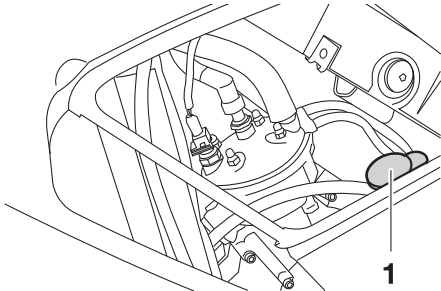

1. Coolant reservoir cap

7. Move the hose clamp in the direction shown, and then disconnect the coolant reservoir hose to drain the reservoir.

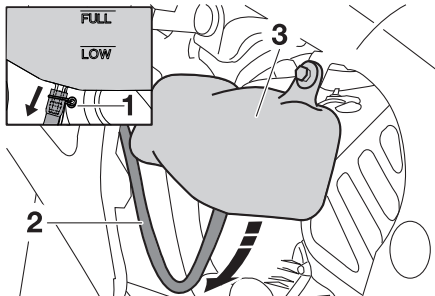

1. Hose clamp
2. Coolant reservoir hose
3. Coolant reservoir

8. After the coolant is completely drained, thoroughly flush the cooling system with clean tap water.
9. Connect the coolant reservoir hose, and then move the hose clamp back to its original position.
10. Install the coolant drain bolt and its new gasket, and then tighten the bolt to the specified torque.

Tightening torque:

Coolant drain bolt:
9 Nm (0.9 m•kgf, 6.5 ft•lbf)

11. Pour the recommended coolant into the reservoir to the maximum level mark, and then install the coolant reservoir cap.
12. Pour the recommended coolant into the radiator until it is full.

Antifreeze/water mixture ratio:
1:1

Recommended antifreeze:

High-quality ethylene glycol antifreeze containing corrosion inhibitors for aluminum engines

Coolant quantity:

Radiator capacity (including all routes):

0.70 L (0.74 US qt, 0.62 Imp.qt)

Coolant reservoir capacity (up to the maximum level mark):

0.29 L (0.31 US qt, 0.26 Imp.qt)

13. Install the radiator cap, start the engine, let it idle for several minutes, and then turn it off.
14. Remove the radiator cap to check the coolant level in the radiator. If necessary, add sufficient coolant until it reaches the top of the radiator, and then install the radiator cap, retainer and retaining bolt.
15. Check the coolant level in the reservoir. If necessary, remove the coolant reservoir cap, add coolant to the maximum level mark, and then install the cap.

PERIODIC MAINTENANCE AND ADJUSTMENT

16. Start the engine, and then check the vehicle for coolant leakage. If coolant is leaking, have a Yamaha dealer check the cooling system.
17. Install the cowlings and panel.

EAU40371

Air filter element

The air filter element should be cleaned or replaced at the intervals specified in the periodic maintenance and lubrication chart. Have a Yamaha dealer clean or replace the air filter element.

EAU21280

Adjusting the carburetor

The carburetor is an important part of the engine and requires very sophisticated adjustment. Therefore, most carburetor adjustments should be left to a Yamaha dealer, who has the necessary professional knowledge and experience. The adjustment described in the following section, however, may be serviced by the owner as part of routine maintenance.

ECA10550

NOTICE

The carburetor has been set and extensively tested at the Yamaha factory. Changing these settings without sufficient technical knowledge may result in poor performance of or damage to the engine.

EAU33482

Adjusting the engine idling speed

The engine idling speed must be checked and, if necessary, adjusted as follows at the intervals specified in the periodic maintenance and lubrication chart.

The engine should be warm before making this adjustment.

1. Remove panel B. (See page 6-8).
2. Check the engine idling speed and, if necessary, adjust it to specification by turning the idle adjusting screw. To increase the engine idling speed, turn the screw in direction (a). To decrease the engine idling speed, turn the screw in direction (b).

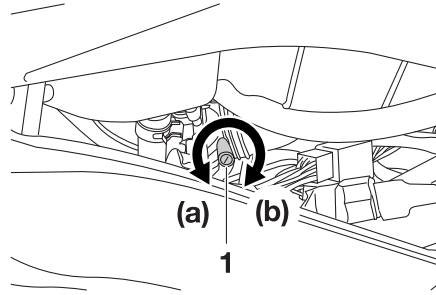

1. Idle adjusting screw

Engine idling speed:
1250–1350 r/min

TIP

If the specified idling speed cannot be obtained as described above, have a Yamaha dealer make the adjustment.

3. Install the panel.

EAU21374

Adjusting the throttle grip free play

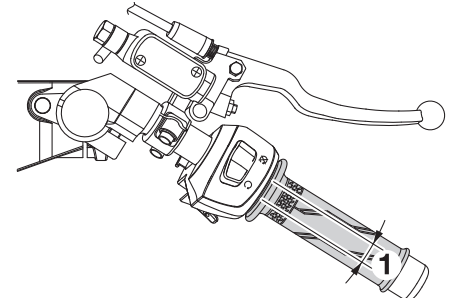

1. Throttle grip free play

The throttle grip free play should measure 4.0–6.0 mm (0.16–0.24 in) as shown. Periodically check the throttle grip free play and, if necessary, adjust it as follows.

TIP

The engine idling speed must be correctly adjusted before checking and adjusting the throttle grip free play.

1. Loosen the locknut.

PERIODIC MAINTENANCE AND ADJUSTMENT

2. To increase the throttle grip free play, turn the throttle grip free play adjusting nut in direction (a). To decrease the throttle grip free play, turn the adjusting nut in direction (b).

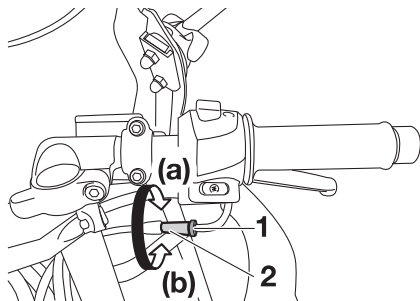

1. Locknut
2. Throttle grip free play adjusting nut

3. Tighten the locknut.

EAU21565

Tires

To maximize the performance, durability, and safe operation of your motorcycle, note the following points regarding the specified tires.

Tire air pressure

The tire air pressure should be checked and, if necessary, adjusted before each ride.

EWA10503



Operation of this vehicle with improper tire pressure may cause severe injury or death from loss of control.

- The tire air pressure must be checked and adjusted on cold tires (i.e., when the temperature of the tires equals the ambient temperature).
- The tire air pressure must be adjusted in accordance with the riding speed and with the total weight of rider, passenger, cargo, and accessories approved for this model.

Tire air pressure (measured on cold tires):

0–90 kg (0–198 lb):

Front:

180 kPa (1.80 kgf/cm²,
26 psi, 1.80 bar)

Rear:

200 kPa (2.00 kgf/cm²,
29 psi, 2.00 bar)

90–193 kg (198–425 lb):

Front:

190 kPa (1.90 kgf/cm²,
28 psi, 1.90 bar)

Rear:

230 kPa (2.30 kgf/cm²,
33 psi, 2.30 bar)

Maximum load*:

196 kg (432 lb)

* Total weight of rider, passenger, cargo and accessories

EWA10511



Never overload your vehicle. Operation of an overloaded vehicle could cause an accident.

PERIODIC MAINTENANCE AND ADJUSTMENT

EWA10471

Tire inspection

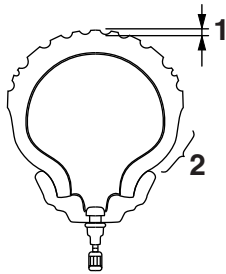

ZALM0054

1. Tire tread depth
2. Tire sidewall

The tires must be checked before each ride. If the center tread depth reaches the specified limit, if the tire has a nail or glass fragments in it, or if the sidewall is cracked, have a Yamaha dealer replace the tire immediately.

Minimum tire tread depth (front and rear):
1.6 mm (0.06 in)

TIP

The tire tread depth limits may differ from country to country. Always comply with the local regulations.

Tire information

This motorcycle is equipped with tubeless tires, tire air valves and cast wheels.

EWA10461

WARNING

The front and rear tires should be of the same make and design, otherwise the handling characteristics of the vehicle may be different, which could lead to an accident.

After extensive tests, only the tires listed below have been approved for this model by Yamaha Motor Co., Ltd.

Front tire:

Size:
100/80 17 (52H)
Manufacturer/model:
Pirelli / Sport Demon
Continental/Conti-Twist SM

Rear tire:

Size:
130/70 17 (62H)
Manufacturer/model:
Pirelli / Sport Demon
Continental/Conti-Twist SM

WARNING

- Have a Yamaha dealer replace excessively worn tires. Besides being illegal, operating the vehicle with excessively worn tires decreases riding stability and can lead to loss of control.
- The replacement of all wheel and brake-related parts, including the tires, should be left to a Yamaha dealer, who has the necessary professional knowledge and experience to do so.
- Ride at moderate speeds after changing a tire since the tire surface must first be “broken in” for it to develop its optimal characteristics.

PERIODIC MAINTENANCE AND ADJUSTMENT

EAU21962

EAU22020

Cast wheels

To maximize the performance, durability, and safe operation of your vehicle, note the following points regarding the specified wheels.

- The wheel rims should be checked for cracks, bends, warpage or other damage before each ride. If any damage is found, have a Yamaha dealer replace the wheel. Do not attempt even the smallest repair to the wheel. A deformed or cracked wheel must be replaced.
- The wheel should be balanced whenever either the tire or wheel has been changed or replaced. An unbalanced wheel can result in poor performance, adverse handling characteristics, and a shortened tire life.

Adjusting the clutch lever free play

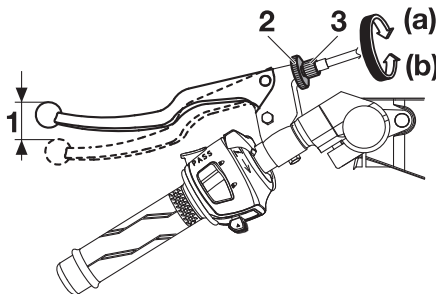

1. Clutch lever free play
2. Locknut
3. Clutch lever free play adjusting bolt

The clutch lever free play should measure 10.0-15.0 mm (0.39-0.59 in) as shown. Periodically check the clutch lever free play and, if necessary, adjust it as follows.

1. Loosen the locknut at the clutch lever.
2. To increase the clutch lever free play, turn the adjusting bolt in direction (a). To decrease the clutch lever free play, turn the adjusting bolt in direction (b).

3. Tighten the locknut.

TIP

If the specified free play cannot be obtained as described above or if the clutch does not operate correctly, have a Yamaha dealer check the internal clutch mechanism.

PERIODIC MAINTENANCE AND ADJUSTMENT

EAUT1221

Checking the front brake lever free play

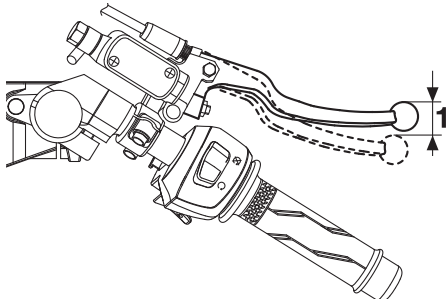

1. Front brake lever free play

The brake lever free play should measure 2.0-5.0 mm (0.08-0.20 in) as shown. Periodically check the brake lever free play and, if necessary, have a Yamaha dealer check the brake system.

EWA10641

⚠ WARNING

An incorrect brake lever free play indicates a hazardous condition in the brake system. Do not operate the vehicle until the brake system has been checked or repaired by a Yamaha dealer.

EAMU1353

Adjusting the brake pedal free play

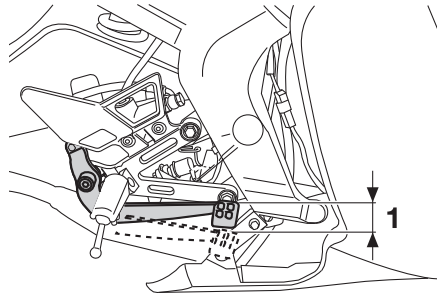

1. Brake pedal free play

The brake pedal free play should measure 5.0-10.0 mm (0.20-0.39 in) as shown. Periodically check the brake pedal free play and, if necessary, have a Yamaha dealer adjust it.

EWAM1030

⚠ WARNING

An incorrect brake pedal free play indicates a hazardous condition in the brake system. Do not operate the motorcycle until the brake system has been checked or repaired by a Yamaha dealer.

EAUB1100

Adjusting the shift pedal position

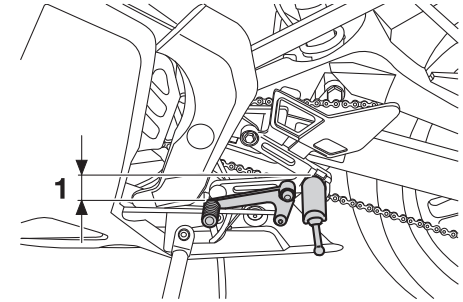

1. Distance between shift pedal and footrest

The top of the shift pedal should be positioned approximately 65 mm (2.56 in) below the top of the footrest as shown. Periodically check the shift pedal position and, if necessary, have a Yamaha dealer adjust it.

PERIODIC MAINTENANCE AND ADJUSTMENT

EAU22273

Brake light switches

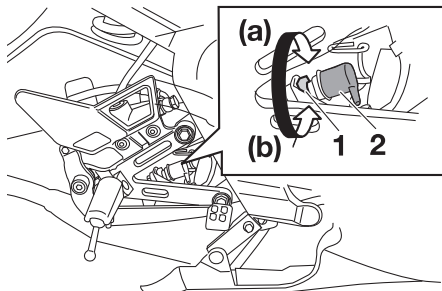

1. Rear brake light switch adjusting nut
2. Brake light switch

6

The brake light, which is activated by the brake pedal and brake lever, should come on just before braking takes effect. If necessary, adjust the rear brake light switch as follows, but the front brake light switch should be adjusted by a Yamaha dealer.

Turn the rear brake light switch adjusting nut while holding the rear brake light switch in place. To make the brake light come on earlier, turn the adjusting nut in direction (a). To make the brake light come on later, turn the adjusting nut in direction (b).

EAU22392

Checking the front and rear brake pads

The front and rear brake pads must be checked for wear at the intervals specified in the periodic maintenance and lubrication chart.

EAU22430

Front brake pads

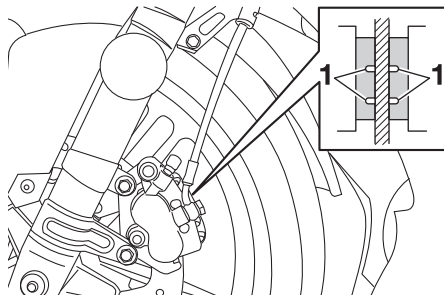

1. Brake pad wear indicator groove

Each front brake pad is provided with wear indicator grooves, which allow you to check the brake pad wear without having to disassemble the brake. To check the brake pad wear, check the wear indicator grooves. If a brake pad has worn to the point that the wear indicator grooves have almost

disappeared, have a Yamaha dealer replace the brake pads as a set.

EAU22480

Rear brake pads

Each rear brake pad is provided with a wear indicator groove, which allows you to check the brake pad wear without having to disassemble the brake. Check the brake pad wear as follows.

1. Remove the brake caliper bolt, and then tilt the caliper forward to inspect the wear indicator groove. If a brake pad has worn to the point that the wear indicator groove has almost disappeared, have a Yamaha dealer replace the brake pads as a set.

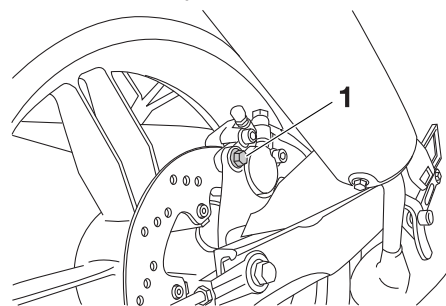

1. Brake caliper bolt

PERIODIC MAINTENANCE AND ADJUSTMENT

EAUJ22580

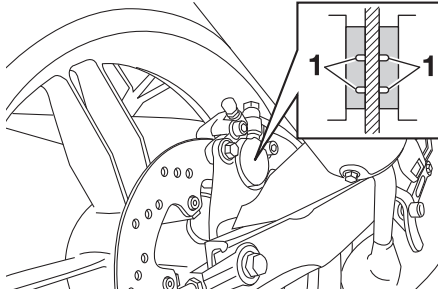

1. Brake pad wear indicator groove

2. Install the brake caliper bolt, and then tighten it to the specified torque.

Tightening torque:

Brake caliper bolt:
30 Nm (3.0 m•kgf, 21.7 ft•lbf)

Checking the brake fluid level

Front brake

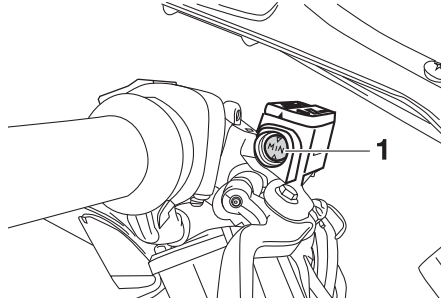

1. Minimum level mark

Rear brake

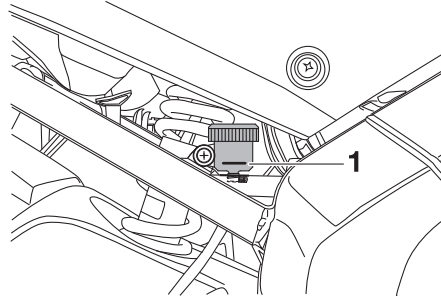

1. Minimum level mark

Insufficient brake fluid may allow air to enter the brake system, possibly causing it to become ineffective.

Before riding, check that the brake fluid is above the minimum level mark and replenish if necessary. A low brake fluid level may indicate worn brake pads and/or brake system leakage. If the brake fluid level is low, be sure to check the brake pads for wear and the brake system for leakage.

Observe these precautions:

- When checking the fluid level, make sure that the top of the brake fluid reservoir is level.
- Use only the recommended quality brake fluid, otherwise the rubber seals may deteriorate, causing leakage and poor braking performance.

Recommended brake fluid:

DOT 4

- Refill with the same type of brake fluid. Mixing fluids may result in a harmful chemical reaction and lead to poor braking performance.

PERIODIC MAINTENANCE AND ADJUSTMENT

- Be careful that water does not enter the brake fluid reservoir when refilling. Water will significantly lower the boiling point of the fluid and may result in vapor lock.
- Brake fluid may deteriorate painted surfaces or plastic parts. Always clean up spilled fluid immediately.
- As the brake pads wear, it is normal for the brake fluid level to gradually go down. However, if the brake fluid level goes down suddenly, have a Yamaha dealer check the cause.

Changing the brake fluid

Have a Yamaha dealer change the brake fluid at the intervals specified in the TIP after the periodic maintenance and lubrication chart. In addition, have the oil seals of the master cylinders and calipers as well as the brake hoses replaced at the intervals listed below or whenever they are damaged or leaking.

- Oil seals: Replace every two years.
- Brake hoses: Replace every four years.

EAU22731

Drive chain slack

The drive chain slack should be checked before each ride and adjusted if necessary.

EAU22760

To check the drive chain slack

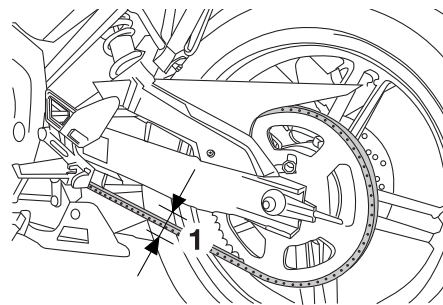

EAU22784

1. Drive chain slack

1. Place the motorcycle on the sidestand.

TIP

When checking and adjusting the drive chain slack, there should be no weight on the motorcycle.

2. Shift the transmission into the neutral position.

PERIODIC MAINTENANCE AND ADJUSTMENT

3. Measure the drive chain slack as shown.

Drive chain slack:
20.0–25.0 mm (0.79–0.98 in)

4. If the drive chain slack is incorrect, adjust it as follows.

TIP

When checking the drive chain slack, the chain tensioner should not be touching the drive chain.

EAU22922

To adjust the drive chain slack

Consult a Yamaha dealer before adjusting the drive chain slack.

1. Remove the cotter pin from the axle nut, and then loosen the axle nut.
2. Loosen the chain puller locknut at each end of the swingarm.
3. To tighten the drive chain, turn the drive chain slack adjusting nut at each end of the swingarm in direction (a). To loosen the drive chain, turn the adjusting nut at each end of the swingarm in

direction (b), and then push the rear wheel forward. **NOTICE: Improper drive chain slack will overload the engine as well as other vital parts of the motorcycle and can lead to chain slippage or breakage. To prevent this from occurring, keep the drive chain slack within the specified limits.** [ECA10571]

TIP

Using the alignment marks on each side of the swingarm, make sure that both adjusting nuts are in the same position for proper wheel alignment.

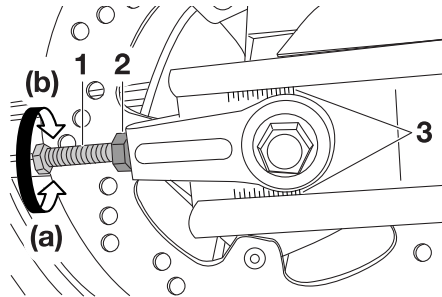

1. Drive chain slack adjusting bolt
2. Drive chain puller locknut
3. Alignment marks

4. Tighten the locknuts, and then tighten the axle nut to the specified torque.

Tightening torque:

Axle nut:
90 Nm (9.0 m•kgf, 65.1 ft•lbf)

5. Insert a new cotter pin into the axle nut, and then bend its ends as shown. **WARNING! Always use a new cotter pin for the axle nut.** [EWA10701]

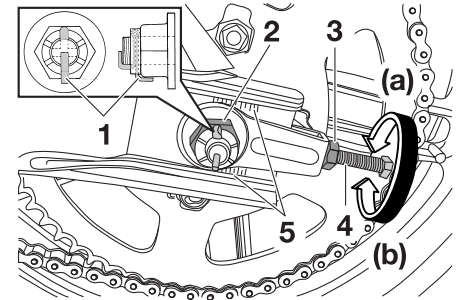

1. Axle nut cotter pin
2. Axle nut
3. Drive chain puller locknut
4. Drive chain slack adjusting bolt
5. Alignment marks

PERIODIC MAINTENANCE AND ADJUSTMENT

TIP

Make sure that two notches in the axle nut are aligned with the hole through the wheel axle, otherwise further tighten the axle nut until they are.

6. Make sure that the drive chain pullers are in the same position, the drive chain slack is correct, and the drive chain moves smoothly.

EAU23025

Cleaning and lubricating the drive chain

The drive chain must be cleaned and lubricated at the intervals specified in the periodic maintenance and lubrication chart, otherwise it will quickly wear out, especially when riding in dusty or wet areas. Service the drive chain as follows.

ECA10583

NOTICE

The drive chain must be lubricated after washing the motorcycle, riding in the rain or riding in wet areas.

1. Clean the drive chain with kerosene and a small soft brush.
NOTICE: To prevent damaging the O-rings, do not clean the drive chain with steam cleaners, high-pressure washers or inappropriate solvents. [ECA11121]
2. Wipe the drive chain dry.
3. Thoroughly lubricate the drive chain with a special O-ring chain lubricant. **NOTICE: Do not use engine oil or any other lubricants for the drive chain, as**

they may contain substances that could damage the O-rings.

[ECA11111]

PERIODIC MAINTENANCE AND ADJUSTMENT

EAU23095

Checking and lubricating the cables

The operation of all control cables and the condition of the cables should be checked before each ride, and the cables and cable ends should be lubricated if necessary. If a cable is damaged or does not move smoothly, have a Yamaha dealer check or replace it. **WARNING! Damage to the outer housing of cables may result in internal rusting and cause interference with cable movement. Replace damaged cables as soon as possible to prevent unsafe conditions.** [EWA10711]

Recommended lubricant:
Yamaha Chain and Cable Lube or engine oil

EAU23114

Checking and lubricating the throttle grip and cable

The operation of the throttle grip should be checked before each ride. In addition, the cable should be lubricated by a Yamaha dealer at the intervals specified in the periodic maintenance chart.

The throttle cable is equipped with a rubber cover. Make sure that the cover is securely installed. Even though the cover is installed correctly, it does not completely protect the cable from water entry. Therefore, use care not to pour water directly onto the cover or cable when washing the vehicle. If the cable or cover becomes dirty, wipe clean with a moist cloth.

EAU23120

Adjusting the Autolube pump

The Autolube pump is a vital and sophisticated component of the engine, which must be adjusted by a Yamaha dealer at the intervals specified in the periodic maintenance and lubrication chart.

PERIODIC MAINTENANCE AND ADJUSTMENT

EAU44272

Checking and lubricating the brake and shift pedals

Brake pedal

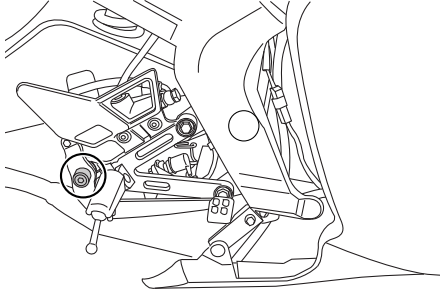

The operation of the brake and shift pedals should be checked before each ride, and the pedal pivots should be lubricated if necessary.

Recommended lubricant:
Lithium-soap-based grease

Shift pedal

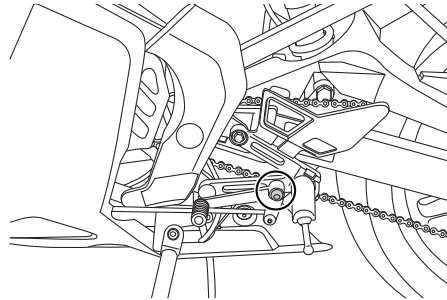

EAU23142

Checking and lubricating the brake and clutch levers

Brake lever

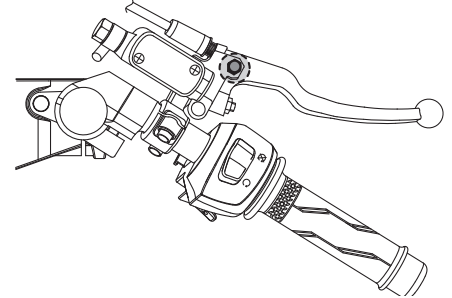

Clutch lever

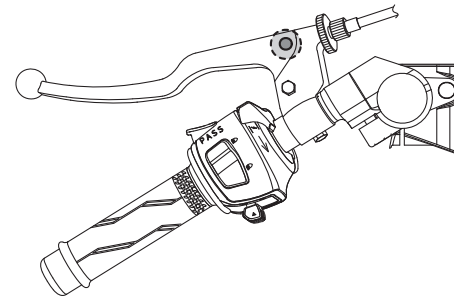

PERIODIC MAINTENANCE AND ADJUSTMENT

The operation of the brake and clutch levers should be checked before each ride, and the lever pivots should be lubricated if necessary.

Recommended lubricants:

- Brake lever:
 - Silicone grease
- Clutch lever:
 - Lithium-soap-based grease

EAU23202

Checking and lubricating the sidestand

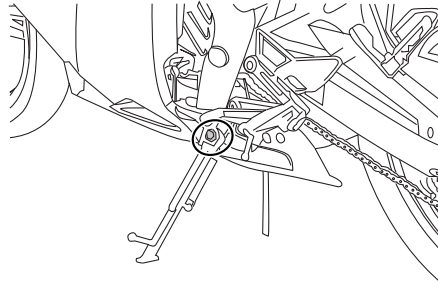

The operation of the sidestand should be checked before each ride, and the sidestand pivot and metal-to-metal contact surfaces should be lubricated if necessary.

Recommended lubricant:
Lithium-soap-based grease

EWA10731

⚠ WARNING

If the sidestand does not move up and down smoothly, have a Yamaha dealer check or repair it. Otherwise, the sidestand could contact the ground and distract the operator, resulting in a possible loss of control.

PERIODIC MAINTENANCE AND ADJUSTMENT

EAU23272

Checking the front fork

The condition and operation of the front fork must be checked as follows at the intervals specified in the periodic maintenance and lubrication chart.

To check the condition

1. Check the inner tubes for scratches, damage and excessive oil leakage.

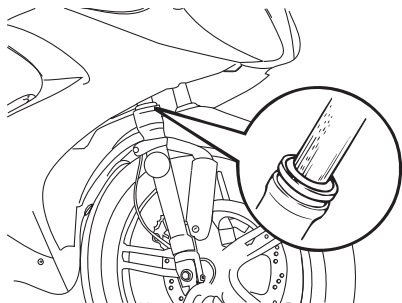

6

To check the operation

1. Place the vehicle on a level surface and hold it in an upright position. **WARNING! To avoid injury, securely support the vehicle so there is no danger of it falling over.** [EWA10751]

2. While applying the front brake, push down hard on the handlebars several times to check if the front fork compresses and rebounds smoothly.

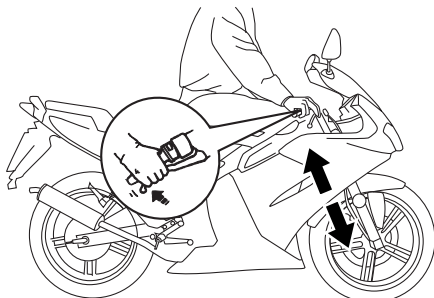

ECA10590

NOTICE

If any damage is found or the front fork does not operate smoothly, have a Yamaha dealer check or repair it.

EAU23283

Checking the steering

Worn or loose steering bearings may cause danger. Therefore, the operation of the steering must be checked as follows at the intervals specified in the periodic maintenance and lubrication chart.

1. Place a stand under the engine to raise the front wheel off the ground. **WARNING! To avoid injury, securely support the vehicle so there is no danger of it falling over.** [EWA10751]
2. Hold the lower ends of the front fork legs and try to move them forward and backward. If any free play can be felt, have a Yamaha dealer check or repair the steering.

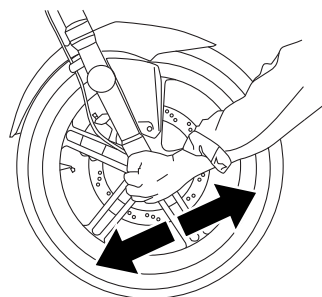

PERIODIC MAINTENANCE AND ADJUSTMENT

EAU23291

Checking the wheel bearings

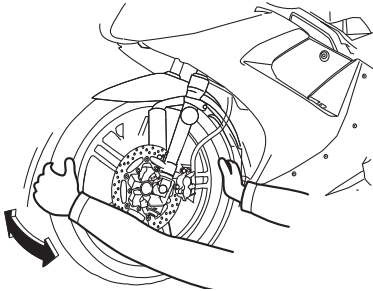

The front and rear wheel bearings must be checked at the intervals specified in the periodic maintenance and lubrication chart. If there is play in the wheel hub or if the wheel does not turn smoothly, have a Yamaha dealer check the wheel bearings.

EAU23445

Battery

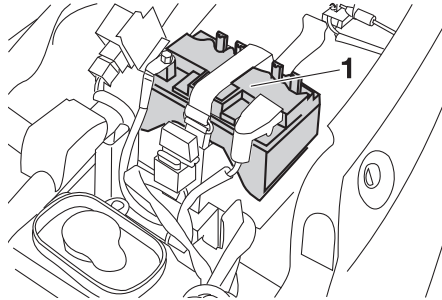

1. Battery

This model is equipped with a VRLA (Valve Regulated Lead Acid) battery. There is no need to check the electrolyte or to add distilled water. However, the battery lead connections need to be checked and, if necessary, tightened.

EWA10760

WARNING

- **Electrolyte is poisonous and dangerous since it contains sulfuric acid, which causes severe burns. Avoid any contact with skin, eyes or clothing and always shield your eyes**

when working near batteries. In case of contact, administer the following **FIRST AID**.

- **EXTERNAL:** Flush with plenty of water.
- **INTERNAL:** Drink large quantities of water or milk and immediately call a physician.
- **EYES:** Flush with water for 15 minutes and seek prompt medical attention.
- **Batteries produce explosive hydrogen gas. Therefore, keep sparks, flames, cigarettes, etc., away from the battery and provide sufficient ventilation when charging it in an enclosed space.**
- **KEEP THIS AND ALL BATTERIES OUT OF THE REACH OF CHILDREN.**

To charge the battery

Have a Yamaha dealer charge the battery as soon as possible if it seems to have discharged. Keep in mind that the battery tends to discharge more quickly if the vehicle is equipped with optional electrical accessories.

PERIODIC MAINTENANCE AND ADJUSTMENT

ECA16521

NOTICE

To charge a VRLA (Valve Regulated Lead Acid) battery, a special (constant-voltage) battery charger is required. Using a conventional battery charger will damage the battery.

To store the battery

1. If the vehicle will not be used for more than one month, remove the battery, fully charge it, and then place it in a cool, dry place.

NOTICE: When removing the battery, be sure the key is turned to “⊗” then disconnect the negative lead before disconnecting the positive lead.

[ECA16302]

2. If the battery will be stored for more than two months, check it at least once a month and fully charge it if necessary.
3. Fully charge the battery before installation. **NOTICE:** When installing the battery, be sure the key is turned to “⊗”, then

connect the positive lead before connecting the negative lead. [ECA16840]

4. After installation, make sure that the battery leads are properly connected to the battery terminals.

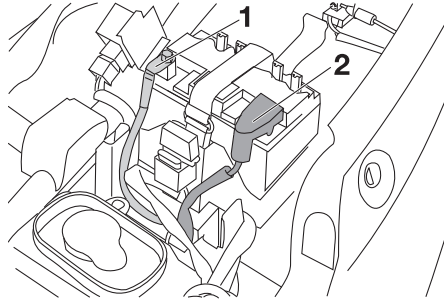

1. Negative battery lead (black)
2. Positive battery lead (red)

ECA16530

NOTICE

Always keep the battery charged. Storing a discharged battery can cause permanent battery damage.

EAU23482

Replacing the fuse

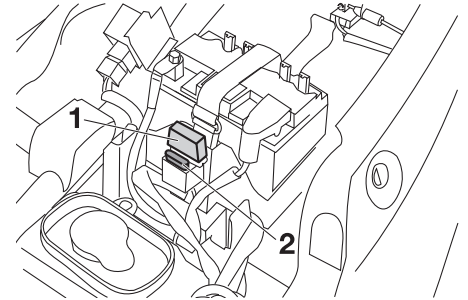

1. Main fuse
2. Spare main fuse

The fuse holder is located under the seat. (See page 3-12).

If the fuse is blown, replace it as follows.

1. Turn the key to “⊗” and turn off all electrical circuits.
2. Remove the blown fuse, and then install a new fuse of the specified amperage. **WARNING! Do not use a fuse of a higher amperage rating than recommended to avoid causing extensive damage to the electrical system and possibly a fire.** [EWA15131]

PERIODIC MAINTENANCE AND ADJUSTMENT

Specified fuse:
10.0 A

EAU23804

3. Turn the key to “ \odot ” and turn on the electrical circuits to check if the devices operate.
4. If the fuse immediately blows again, have a Yamaha dealer check the electrical system.

Replacing the headlight bulb

This model is equipped with a halogen bulb headlight. If the headlight bulb burns out, replace it as follows.

ECA10650

NOTICE

Take care not to damage the following parts:

- **Headlight bulb**

Do not touch the glass part of the headlight bulb to keep it free from oil, otherwise the transparency of the glass, the luminosity of the bulb, and the bulb life will be adversely affected. Thoroughly clean off any dirt and fingerprints on the headlight bulb using a cloth moistened with alcohol or thinner.

- **Headlight lens**

Do not affix any type of tinted film or stickers to the headlight lens.

Do not use a headlight bulb of a wattage higher than specified.

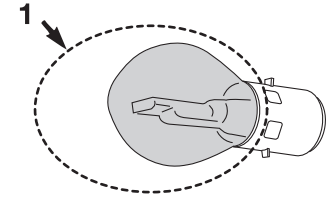

1. Do not touch the glass part of the bulb.

1. Remove the headlight bulb cover, and then disconnect the headlight lead connectors.

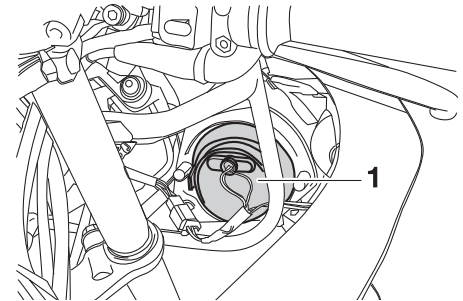

1. Headlight bulb cover

2. Unhook the headlight bulb holder, and then remove the burnt-out bulb.

PERIODIC MAINTENANCE AND ADJUSTMENT

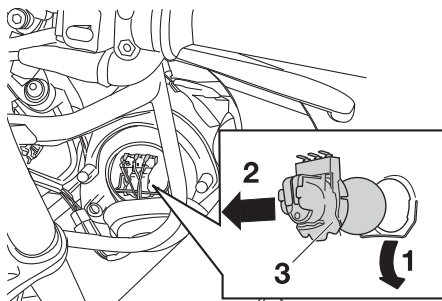

1. Unhook the headlight bulb holder
2. Take the headlight bulb holder off
3. Headlight bulb holder

3. Place a new headlight bulb into position, and then secure it with the bulb holder.
4. Connect the headlight lead connectors, and then install the bulb cover.
5. Have a Yamaha dealer adjust the headlight beam if necessary.

6

EAU24133

Replacing the tail/brake light bulb

1. Remove the tail/brake light lens by removing the screws.

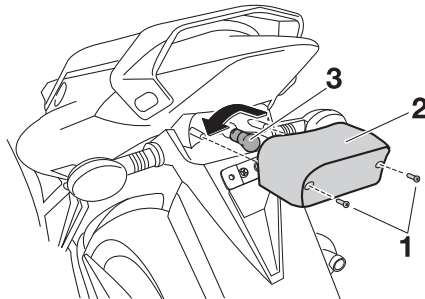

1. Screw
2. Tail/Brake light lens
3. Tail/brake light bulb

2. Remove the burnt-out bulb by pushing it in and turning it counterclockwise.
3. Insert a new bulb into the socket, push it in, and then turn it clockwise until it stops.
4. Install the lens by installing the screws. **NOTICE: Do not overtighten the screws, otherwise the lens may break.** [ECA10681]

EAU1352

Replacing a front turn signal light bulb

ECA10670

NOTICE

It is advisable to have a Yamaha dealer perform this job.

1. Remove the socket (together with the bulb) by turning it counterclockwise for the right turn signal and turning it clockwise for the left turn signal.

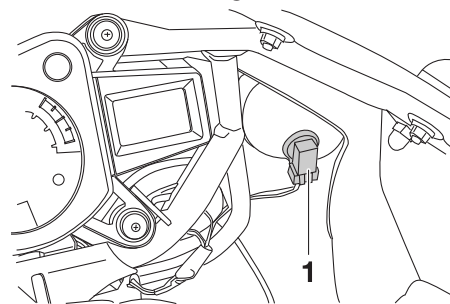

1. Turn signal light bulb socket
2. Remove the burnt out bulb by pulling it out.

PERIODIC MAINTENANCE AND ADJUSTMENT

EAUS1610

EAUM1461

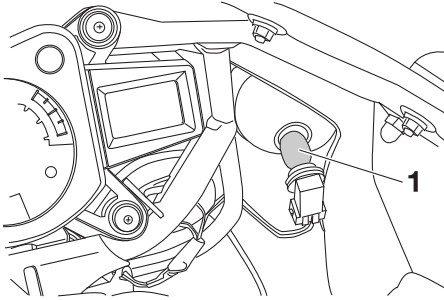

1. Turn signal light bulb

3. Insert a new bulb into the socket.
4. Install the socket (together with the bulb) by turning it clockwise for the right turn signal and turning it counterclockwise for the left turn signal.

Replacing a rear turn signal light bulb

1. Remove the turn signal lens by removing the screw.

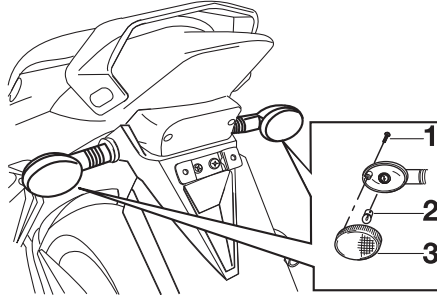

1. Screw
2. Turn signal light bulb
3. Turn signal light lens

2. Remove the burnt-out bulb by pushing it in and turning it counterclockwise.
3. Insert a new bulb into the socket, push it in, and then turn it clockwise until it stops.
4. Install the lens by installing the screw. **NOTICE: Do not over-tighten the screw, otherwise the lens may break.** [ECA11191]

Replacing the license plate light bulb

1. Remove the license plate light cover by removing the screw.

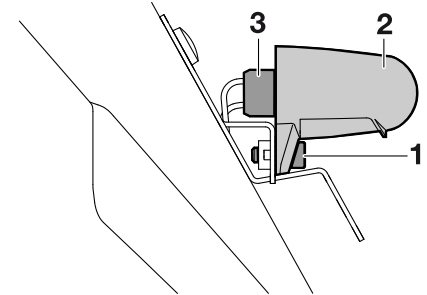

1. Screw
2. License plate light cover
3. License plate light bulb socket

2. Remove the socket (together with the bulb) by pulling it out.

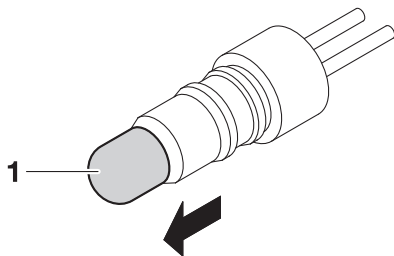

1. Bulb

3. Remove the burnt out bulb by pulling it out.
4. Insert a new bulb into the socket.
5. Install the socket (together with the bulb) by pushing it in.
6. Install the license plate light cover by installing the screw.

Troubleshooting

Although Yamaha motorcycles receive a thorough inspection before shipment from the factory, trouble may occur during operation. Any problem in the fuel, compression, or ignition systems, for example, can cause poor starting and loss of power.

The following troubleshooting charts represent quick and easy procedures for checking these vital systems yourself. However, should your motorcycle require any repair, take it to a Yamaha dealer, whose skilled technicians have the necessary tools, experience, and know-how to service the motorcycle properly.

Use only genuine Yamaha replacement parts. Imitation parts may look like Yamaha parts, but they are often inferior, have a shorter service life and can lead to expensive repair bills.

WARNING

When checking the fuel system, do not smoke, and make sure there are no open flames or sparks in the area, including pilot lights from water heaters or furnaces. Gasoline or gasoline vapors can ignite or explode, causing severe injury or property damage.

Troubleshooting charts

Starting problems or poor engine performance

1. Fuel

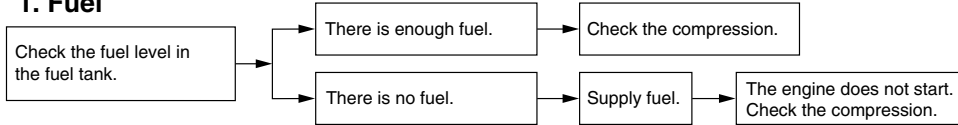

2. Compression

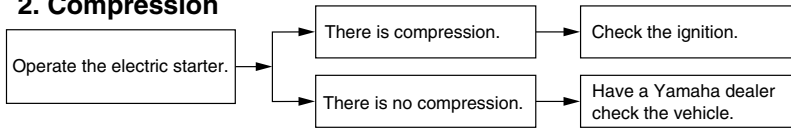

3. Ignition

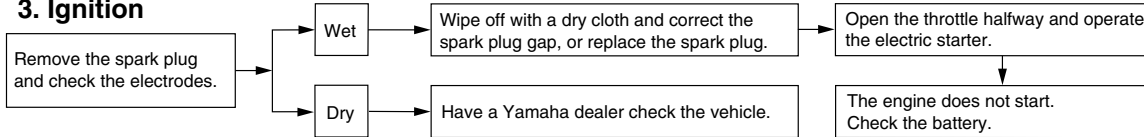

4. Battery

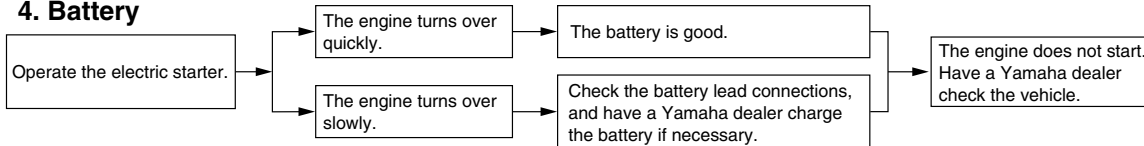

PERIODIC MAINTENANCE AND ADJUSTMENT

Engine overheating

EWA10400

WARNING

- Do not remove the radiator cap when the engine and radiator are hot. Scalding hot fluid and steam may be blown out under pressure, which could cause serious injury. Be sure to wait until the engine has cooled.
- After removing the radiator cap retaining bolt, place a thick rag, like a towel, over the radiator cap, and then slowly rotate the cap counterclockwise to the detent to allow any residual pressure to escape. When the hissing sound has stopped, press down on the cap while turning it counterclockwise, and then remove the cap.

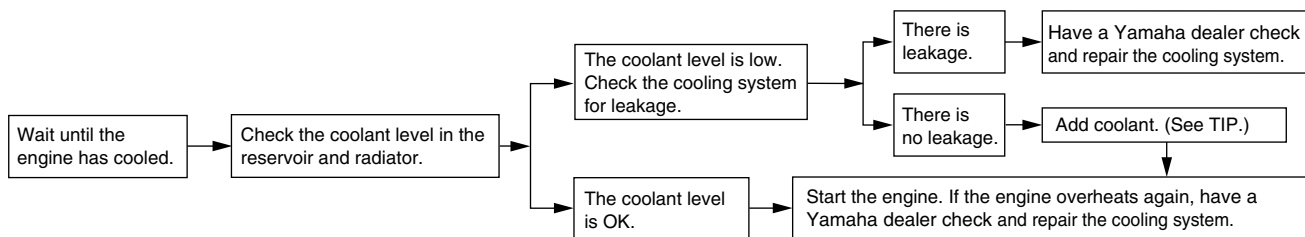

TIP

If coolant is not available, tap water can be temporarily used instead, provided that it is changed to the recommended coolant as soon as possible.

MOTORCYCLE CARE AND STORAGE

EAU37833

EAU26004

Matte color caution

ECA15192

NOTICE

Some models are equipped with matte colored finished parts. Be sure to consult a Yamaha dealer for advice on what products to use before cleaning the vehicle.

Using a brush, harsh chemical products or cleaning compounds when cleaning these parts will scratch or damage their surface. Wax also should not be applied to any matte colored finished parts.

Care

While the open design of a motorcycle reveals the attractiveness of the technology, it also makes it more vulnerable. Rust and corrosion can develop even if high-quality components are used. A rusty exhaust pipe may go unnoticed on a car, however, it detracts from the overall appearance of a motorcycle. Frequent and proper care does not only comply with the terms of the warranty, but it will also keep your motorcycle looking good, extend its life and optimize its performance.

Before cleaning

1. Cover the muffler outlet with a plastic bag after the engine has cooled down.
2. Make sure that all caps and covers as well as all electrical couplers and connectors, including the spark plug cap, are tightly installed.
3. Remove extremely stubborn dirt, like oil burnt onto the crankcase, with a degreasing agent and a

brush, but never apply such products onto seals, gaskets, sprockets, the drive chain and wheel axles. Always rinse the dirt and degreaser off with water.

Cleaning

ECA10772

NOTICE

- **Avoid using strong acidic wheel cleaners, especially on spoked wheels. If such products are used on hard-to-remove dirt, do not leave the cleaner on the affected area any longer than instructed. Also, thoroughly rinse the area off with water, immediately dry it, and then apply a corrosion protection spray.**
- **Improper cleaning can damage plastic parts (such as cowlings, panels, windshields, headlight lenses, meter lenses, etc.) and the mufflers. Use only a soft, clean cloth or sponge with water to clean plastic. However, if the plastic parts cannot be thoroughly cleaned with**

MOTORCYCLE CARE AND STORAGE

water, diluted mild detergent with water may be used. Be sure to rinse off any detergent residue using plenty of water, as it is harmful to plastic parts.

- Do not use any harsh chemical products on plastic parts. Be sure to avoid using cloths or sponges which have been in contact with strong or abrasive cleaning products, solvent or thinner, fuel (gasoline), rust removers or inhibitors, brake fluid, antifreeze or electrolyte.
- Do not use high-pressure washers or steam-jet cleaners since they cause water seepage and deterioration in the following areas: seals (of wheel and swingarm bearings, fork and brakes), electric components (couplers, connectors, instruments, switches and lights), breather hoses and vents.
- For motorcycles equipped with a windshield: Do not use strong cleaners or hard sponges as they will cause dulling or scratching. Some cleaning com-

pounds for plastic may leave scratches on the windshield. Test the product on a small hidden part of the windshield to make sure that it does not leave any marks. If the windshield is scratched, use a quality plastic polishing compound after washing.

After normal use

Remove dirt with warm water, a mild detergent, and a soft, clean sponge, and then rinse thoroughly with clean water. Use a toothbrush or bottlebrush for hard-to-reach areas. Stubborn dirt and insects will come off more easily if the area is covered with a wet cloth for a few minutes before cleaning.

After riding in the rain, near the sea or on salt-sprayed roads

Since sea salt or salt sprayed on roads during winter are extremely corrosive in combination with water, carry out the following steps after each ride in the rain, near the sea or on salt-sprayed roads.

TIP

Salt sprayed on roads in the winter may remain well into spring.

1. Clean the motorcycle with cold water and a mild detergent, after the engine has cooled down.
NOTICE: Do not use warm water since it increases the corrosive action of the salt.

[ECA10791]

2. Apply a corrosion protection spray on all metal, including chrome- and nickel-plated, surfaces to prevent corrosion.

After cleaning

1. Dry the motorcycle with a chamois or an absorbing cloth.
2. Immediately dry the drive chain and lubricate it to prevent it from rusting.
3. Use a chrome polish to shine chrome, aluminum and stainless-steel parts, including the exhaust system. (Even the thermally induced discoloring of stainless-steel exhaust systems can be removed through polishing.)

MOTORCYCLE CARE AND STORAGE

ECA10800

EAU37222

4. To prevent corrosion, it is recommended to apply a corrosion protection spray on all metal, including chrome- and nickel-plated, surfaces.
5. Use spray oil as a universal cleaner to remove any remaining dirt.
6. Touch up minor paint damage caused by stones, etc.
7. Wax all painted surfaces.
8. Let the motorcycle dry completely before storing or covering it.

EWA11131

WARNING

Contaminants on the brakes or tires can cause loss of control.

- Make sure that there is no oil or wax on the brakes or tires.
- If necessary, clean the brake discs and brake linings with a regular brake disc cleaner or acetone, and wash the tires with warm water and a mild detergent. Before riding at higher speeds, test the motorcycle's braking performance and cornering behavior.

NOTICE

- Apply spray oil and wax sparingly and make sure to wipe off any excess.
- Never apply oil or wax to any rubber and plastic parts, but treat them with a suitable care product.
- Avoid using abrasive polishing compounds as they will wear away the paint.

TIP

- Consult a Yamaha dealer for advice on what products to use.
- Washing, rainy weather or humid climates can cause the headlight lens to fog. Turning the headlight on for a short period of time will help remove the moisture from the lens.

Storage

Short-term

Always store your motorcycle in a cool, dry place and, if necessary, protect it against dust with a porous cover. Be sure the engine and the exhaust system are cool before covering the motorcycle.

ECA10810

NOTICE

- Storing the motorcycle in a poorly ventilated room or covering it with a tarp, while it is still wet, will allow water and humidity to seep in and cause rust.
- To prevent corrosion, avoid damp cellars, stables (because of the presence of ammonia) and areas where strong chemicals are stored.

Long-term

Before storing your motorcycle for several months:

1. Follow all the instructions in the "Care" section of this chapter.

MOTORCYCLE CARE AND STORAGE

2. Turn the fuel cock lever to “OFF”.
3. Drain the carburetor float chamber by loosening the drain bolt; this will prevent fuel deposits from building up. Pour the drained fuel into the fuel tank.
4. Fill up the fuel tank and add fuel stabilizer (if available) to prevent the fuel tank from rusting and the fuel from deteriorating.
5. Perform the following steps to protect the cylinder, piston rings, etc. from corrosion.
 - a. Remove the spark plug cap and spark plug.
 - b. Pour a teaspoonful of engine oil into the spark plug bore.
 - c. Install the spark plug cap onto the spark plug, and then place the spark plug on the cylinder head so that the electrodes are grounded. (This will limit sparking during the next step.)
 - d. Turn the engine over several times with the starter. (This will coat the cylinder wall with oil.)
 - e. Remove the spark plug cap from the spark plug, and then install the spark plug and the spark plug cap. **WARNING! To prevent damage or injury from sparking, make sure to ground the spark plug electrodes while turning the engine over.** [EWA10951]
6. Lubricate all control cables and the pivoting points of all levers and pedals as well as of the sidestand/centerstand.
7. Check and, if necessary, correct the tire air pressure, and then lift the motorcycle so that both of its wheels are off the ground. Alternatively, turn the wheels a little every month in order to prevent the tires from becoming degraded in one spot.
8. Cover the muffler outlet with a plastic bag to prevent moisture from entering it.
9. Remove the battery and fully charge it. Store it in a cool, dry place and charge it once a month. Do not store the battery in an excessively cold or warm pla-

ce [less than 0 °C (30 °F) or more than 30 °C (90 °F)]. For more information on storing the battery, see page 6-32.

TIP

Make any necessary repairs before storing the motorcycle.

Dimensions:

- Overall length:
2202 mm (86.7 in)
- Overall width:
689 mm (27.1 in)
- Overall height:
1175 mm (46.3 in)
- Seat height:
820 mm (32.3 in)
- Wheelbase:
1341 mm (52.8 in)
- Ground clearance:
151 mm (5.94 in)
- Minimum turning radius:
2900 mm (114.2 in)

Weight:

- Curb weight:
124 kg (273 lb)

Engine:

- Engine type:
Liquid cooled 2-stroke
- Cylinder arrangement:
Single cylinder
- Displacement:
49 cm³
- Bore x stroke:
40.3 x 39.0 mm (1.59 x 1.54 in)
- Compression ratio:
11.50 : 1
- Starting system:
Electric starter
- Lubrication system:
Wet sump

Engine oil:

- Type:
YAMALUBE 2S or 2-stroke engine oil (JASO FC grade) or (ISO EG-C or EG-D grade)

Engine oil quantity:

- Quantity:
1.40 L (1.48 US qt, 1.23 Imp.qt)

Transmission oil:

- Transmission oil change quantity:
0.75 L (0.79 US qt, 0.66 Imp.qt)
- Type:
SAE10W-30 type SE motor oil

Cooling system:

- Coolant reservoir capacity (up to the maximum level mark):
0.29 L (0.31 US qt, 0.26 Imp.qt)
- Radiator capacity (including all routes):
0.70 L (0.74 US qt, 0.62 Imp.qt)

Air filter:

- Air filter element:
Wet element

Fuel:

- Recommended fuel:
Premium unleaded gasoline only
- Fuel tank capacity:
13.8 L (3.65 US gal, 3.04 Imp.gal)
- Fuel reserve amount:
2.2 L (0.58 US gal, 0.48 Imp.gal)

Carburetor:

- Manufacturer:
DELL'ORTO
- Type x quantity:
PHBN 16 / DELL'ORTO x1

Spark plug(s):

- Manufacturer/model:
NGK / BR9 ES
- Spark plug gap:
0.6–0.7 mm (0.024–0.028 in)
- Clutch type:
Wet, multiple-disc

Transmission:

- Primary reduction ratio:
71/20 (3.55)
- Secondary reduction ratio:
60/11 (5.45)
- Final drive:
Chain
- Transmission type:
Constant mesh 6-speed
- Operation:
Left foot operation

Gear ratio:

- 1st:
36/12 (3.00)
- 2nd:
33/16 (2.062)
- 3rd:
29/19 (1.526)
- 4th:
32/24 (1.227)
- 5th:
25/24 (1.041)
- 6th:
24/25 (0.960)

Chassis:

- Frame type:
Double cradle

SPECIFICATIONS

Caster angle:

25.00 °

Trail:

90 mm (3.5 in)

Front tire:

Type:

Tubeless

Size:

100/80 17 (52H)

Manufacturer/model:

Pirelli / Sport Demon

Manufacturer/model:

Continental/Conti-Twist SM

Rear tire:

Type:

Tubeless

Size:

130/70 17 (62H)

Manufacturer/model:

Pirelli / Sport Demon

Manufacturer/model:

Continental/Conti-Twist SM

Maximum load:

196 kg (432 lb)

Tire air pressure (measured on cold tires):

Loading condition:

0–90 kg (0–198 lb)

Front:

180 kPa (1.80 kgf/cm², 26 psi, 1.80 bar)

Rear:

200 kPa (2.00 kgf/cm², 29 psi, 2.00 bar)

Loading condition:

90–193 kg (198–425 lb)

Front:

190 kPa (1.90 kgf/cm², 28 psi, 1.90 bar)

Rear:

230 kPa (2.30 kgf/cm², 33 psi, 2.30 bar)

High-speed riding:

Front:

190 kPa (1.90 kgf/cm², 28 psi, 1.90 bar)

Rear:

230 kPa (2.30 kgf/cm², 33 psi, 2.30 bar)

Front wheel:

Wheel type:

Cast wheel

Rim size:

17M/C x MT2.50

Rear wheel:

Wheel type:

Cast wheel

Rim size:

17M/C x MT3.50

Front brake:

Type:

Single disc brake

Operation:

Right hand operation

Recommended fluid:

DOT 4

Rear brake:

Type:

Single disc brake

Operation:

Right foot operation

Recommended fluid:

DOT 4

Front suspension:

Type:

Telescopic fork

Spring/shock absorber type:

Coil spring/oil damper

Wheel travel:

108.0 mm (4.25 in)

Rear suspension:

Type:

Swingarm (link suspension)

Spring/shock absorber type:

Coil spring/oil damper

Wheel travel:

89.2 mm (3.51 in)

Electrical system:

Ignition system:

DC CDI

Charging system:

Flywheel magneto

Battery:

Model:

GT4L-BS

Voltage, capacity:

12 V, 3.0 Ah

Headlight:

Bulb type:

Incandescence

Bulb voltage, wattage x quantity:

Headlight:

12 V, 25 W/25 W x 2

Headlight:

12 V, 25 W x 2

Tail/brake light:

12 V, 5.0 W/21.0 W x 1

Front turn signal light:

12 V, 16.0 W x 2

Rear turn signal light:

12 V, 10.0 W x 2

License plate light:

12 V, 5.0 W x 1

Meter lighting:

LED

Neutral indicator light:

LED

Oil level warning light:

LED

Turn signal indicator light:

LED

Coolant temperature warning light:

LED

Engine trouble warning light:

LED

Fuses:

Main fuse:

10.0 A

Spare fuse:

10.0 A

CONSUMER INFORMATION

EAU48612

Identification numbers

Record the vehicle identification number and model label information in the spaces provided below for assistance when ordering spare parts from a Yamaha dealer or for reference in case the vehicle is stolen.

VEHICLE IDENTIFICATION NUMBER:

MODEL LABEL INFORMATION:

EAU26400

Vehicle identification number

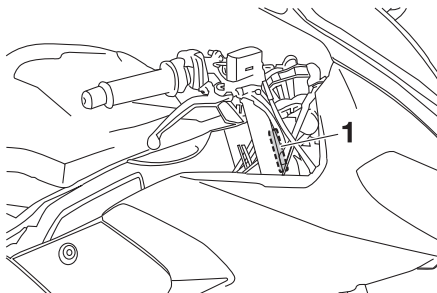

1. Vehicle identification number

The vehicle identification number is stamped into the steering head pipe. Record this number in the space provided.

TIP

The vehicle identification number is used to identify your motorcycle and may be used to register your motorcycle with the licensing authority in your area.

EAU26480

Model label

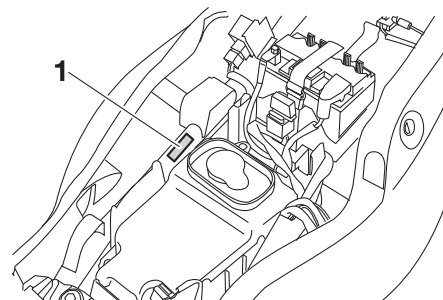

1. Model label

The model label is affixed to the frame under the seat. (See page 3-12). Record the information on this label in the space provided. This information will be needed when ordering spare parts from a Yamaha dealer.

- A**
- Air filter element6-17
 - Anti-theft device housing3-13
 - Autolube pump, adjusting6-28
- B**
- Battery6-32
 - Brake and clutch levers, checking and lubricating6-29
 - Brake and shift pedals, checking and lubricating6-29
 - Brake fluid level, checking6-24
 - Brake fluid, changing6-25
 - Brake lever3-6
 - Brake light switches6-23
 - Brake pedal3-6
 - Brake pedal free play, adjusting6-22
- C**
- Cables, checking and lubricating6-28
 - Carburetor, adjusting6-17
 - Care7-1
 - Catalytic converter3-9
 - Clutch lever3-5
 - Clutch lever free play, adjusting6-21
 - Coolant6-14
 - Coolant temperature warning light3-3
 - Cowlings and panels, removing and installing6-8
- D**
- Dimmer switch3-5
 - Drive chain slack6-25
 - Drive chain, cleaning and lubricating6-27
- E**
- Engine break-in5-3
 - Engine idling speed6-18
- F**
- Engine oil3-10
 - Engine stop switch3-5
 - Engine trouble warning light3-3
 - Engine, starting a warm5-2
- F**
- Front and rear brake pads, checking6-23
 - Front brake lever free play, checking6-22
 - Front fork, checking6-31
 - Fuel3-8
 - Fuel cock3-11
 - Fuel consumption, tips for reducing5-3
 - Fuel tank breather/overflow hose3-9
 - Fuel tank cap3-7
 - Fuse, replacing6-33
- H**
- Handlebar switches3-4
 - Headlight bulb, replacing6-34
 - Horn switch3-5
- I**
- Identification numbers9-1
 - Ignition circuit cut-off system3-14
 - Indicator and warning lights3-2
- L**
- License plate light bulb, replacing6-36
- M**
- Main switch/steering lock3-1
 - Maintenance and lubrication, periodic6-4
 - Maintenance, emission control system6-3
 - Matte color, caution7-1
 - Model label9-1
- N**
- Neutral indicator light3-2
- O**
- Oil level warning light3-2
- P**
- Parking5-4
 - Part locations2-1
 - Pass switch3-5
- R**
- Rear view mirrors3-13
- S**
- Safety information1-1
 - Seat3-12
 - Shift pedal3-6
 - Shift pedal position, adjusting6-22
 - Shifting5-2
 - Sidestand3-14
 - Sidestand, checking and lubricating6-30
 - Spark plug, checking6-11
 - Specifications8-1
 - Speedometer unit3-3
 - Start switch3-5
 - Starter (choke) lever3-12
 - Starting a cold engine5-1
 - Steering, checking6-31
 - Storage7-3
- T**
- Tachometer3-4
 - Tail/brake light bulb, replacing6-35
 - Throttle grip and cable, checking and lubricating6-28
 - Throttle grip free play, adjusting6-18
 - Tires6-19
 - Tool kit6-1
 - Transmission oil6-13
 - Troubleshooting6-37
 - Troubleshooting charts6-38
 - Turn signal indicator light3-2

INDEX

Turn signal light bulb (front), replacing6-35
Turn signal light bulb (rear), replacing.....6-36
Turn signal switch3-5

V

Vehicle identification number.....9-1

W

Wheel bearings, checking.....6-32
Wheels6-21



MBK Industrie

Z.I. de Rouvroy 02100 Saint Quentin

Société Anonyme au capital de 45 000 000 €

R.C St-Quentin B 329 035 422

PRINTED IN THE NETHERLANDS

2012-04

(E)