



 Read this manual carefully before operating this vehicle.

OWNER'S MANUAL

**TENERE**

**XT660Z**

2BD-F8199-20



**Read this manual carefully before operating this vehicle. This manual should stay with this vehicle if it is sold.**

Welcome to the Yamaha world of motorcycling!

As the owner of the XT660Z Ténéré, you are benefiting from Yamaha's vast experience and newest technology regarding the design and manufacture of high-quality products, which have earned Yamaha a reputation for dependability.

Please take the time to read this manual thoroughly, so as to enjoy all advantages of your XT660Z Ténéré. The Owner's Manual does not only instruct you in how to operate, inspect and maintain your motorcycle, but also in how to safeguard yourself and others from trouble and injury.

In addition, the many tips given in this manual will help keep your motorcycle in the best possible condition. If you have any further questions, do not hesitate to contact your Yamaha dealer.

The Yamaha team wishes you many safe and pleasant rides. So, remember to put safety first!

Yamaha continually seeks advancements in product design and quality. Therefore, while this manual contains the most current product information available at the time of printing, there may be minor discrepancies between your motorcycle and this manual. If there is any question concerning this manual, please consult a Yamaha dealer.

---

 **WARNING**

**Please read this manual carefully and completely before operating this motorcycle.**



---

# IMPORTANT MANUAL INFORMATION

---

EAU10132

Particularly important information is distinguished in this manual by the following notations:

	<p><b>This is the safety alert symbol. It is used to alert you to potential personal injury hazards. Obey all safety messages that follow this symbol to avoid possible injury or death.</b></p>
	<p><b>A WARNING indicates a hazardous situation which, if not avoided, could result in death or serious injury.</b></p>
	<p><b>A NOTICE indicates special precautions that must be taken to avoid damage to the vehicle or other property.</b></p>
<p><b>TIP</b></p>	<p>A TIP provides key information to make procedures easier or clearer.</p>

# IMPORTANT MANUAL INFORMATION

---

EAUB1011

**XT660Z  
OWNER'S MANUAL  
©2012 by MBK INDUSTRIE  
1<sup>st</sup> edition, March 2012  
All rights reserved.  
Any reprinting or unauthorized use  
without the written permission of  
MBK INDUSTRIE  
is expressly prohibited.  
Printed in France.**

# TABLE OF CONTENTS

---

## LOCATION OF IMPORTANT LABELS...1-1

## SAFETY INFORMATION .....2-1

- Be a Responsible Owner .....2-1
- Safe riding.....2-1
- Protective apparel .....2-2
- Avoid Carbon Monoxide Poisoning...2-2
- Loading .....2-3
- Genuine Yamaha Accessories .....2-3
- Aftermarket Parts, Accessories,  
and Modifications .....2-4
- Aftermarket Tires and Rims .....2-4

## DESCRIPTION .....3-1

- Left view .....3-1
- Right view .....3-2
- Controls and instruments .....3-3

## INSTRUMENT AND CONTROL

### FUNCTIONS .....4-1

- Immobilizer system .....4-1
- Main switch/steering lock .....4-2
- Indicator and warning lights .....4-3
- Multi-function display .....4-5
- Tachometer .....4-6
- Tripmeter and tachometer modes .....4-6
- Clock mode .....4-7
- Fuel meter.....4-7
- Self-diagnosis devices .....4-7

- Handlebar switches.....4-9
- Clutch lever .....4-10
- Shift pedal .....4-10
- Brake lever .....4-11
- Brake pedal .....4-11
- Fuel tank cap .....4-11
- Fuel .....4-12
- Fuel tank breather hose.....4-13
- Catalytic converter .....4-13
- Seat.....4-14
- Adjusting the front fork.....4-15
- Adjusting the shock absorber  
assembly .....4-16
- Sidestand .....4-17
- Ignition circuit cut-off system .....4-17

## FOR YOUR SAFETY -

### PRE-OPERATION CHECKS .....5-1

- Pre-operation check list .....5-2

## OPERATION AND IMPORTANT

### RIDING POINTS .....6-1

- Starting the engine.....6-1
- Shifting .....6-2
- Tips for reducing fuel consumption...6-3
- Engine break-in.....6-3
- Parking.....6-4

## PERIODIC MAINTENANCE AND

### ADJUSTMENT .....7-1

- Owner's tool kit .....7-1
- Periodic maintenance chart for  
the emission control system.....7-2
- General maintenance  
and lubrication chart .....7-3
- Removing and installing  
the cowling and panels .....7-8
- Checking the spark plug .....7-8
- Engine oil and oil filter element.....7-9
- Coolant.....7-12
- Replacing the air filter element  
and cleaning the check hose ...7-14
- Checking the engine idling speed...7-15
- Checking the throttle cable  
free play .....7-16
- Valve clearance.....7-16
- Tires .....7-16
- Spoke wheels.....7-19
- Adjusting the clutch lever free play...7-20
- Checking the front and rear  
brake pads .....7-21
- Checking the brake fluid level .....7-22
- Changing the brake fluid.....7-23
- Drive chain slack.....7-23
- Cleaning and lubricating  
the drive chain.....7-25

# TABLE OF CONTENTS

Checking and lubricating the cables.....7-25	<b>MOTORCYCLE CARE AND STORAGE</b> .....8-1
Checking and lubricating the throttle grip and cable .....7-26	Care .....8-1
Checking and lubricating the brake and clutch levers .....7-26	Storage .....8-3
Lubricating the brake pedal .....7-27	<b>SPECIFICATIONS</b> .....9-1
Checking and lubricating the sidestand.....7-27	<b>CONSUMER INFORMATION</b> .....10-1
Lubricating the rear suspension.....7-27	Identification numbers.....10-1
Lubricating the swingarm pivots .....7-28	Motorcycle noise regulation (for Australia).....10-2
Checking the front fork.....7-28	
Checking the steering .....7-29	
Checking the wheel bearings.....7-29	
Battery.....7-30	
Replacing the fuses .....7-31	
Replacing a headlight bulb .....7-33	
Replacing a turn signal light bulb....7-34	
Replacing the license plate light bulb.....7-35	
Replacing an auxiliary light bulb .....7-35	
Supporting the motorcycle .....7-36	
Front wheel .....7-36	
Rear wheel.....7-38	
Troubleshooting .....7-39	
Troubleshooting charts.....7-40	

# LOCATION OF IMPORTANT LABELS

---

EAU10383

Read and understand all of the labels on your vehicle. They contain important information for safe and proper operation of your vehicle. Never remove any labels from your vehicle. If a label becomes difficult to read or comes off, a replacement label is available from your Yamaha dealer.

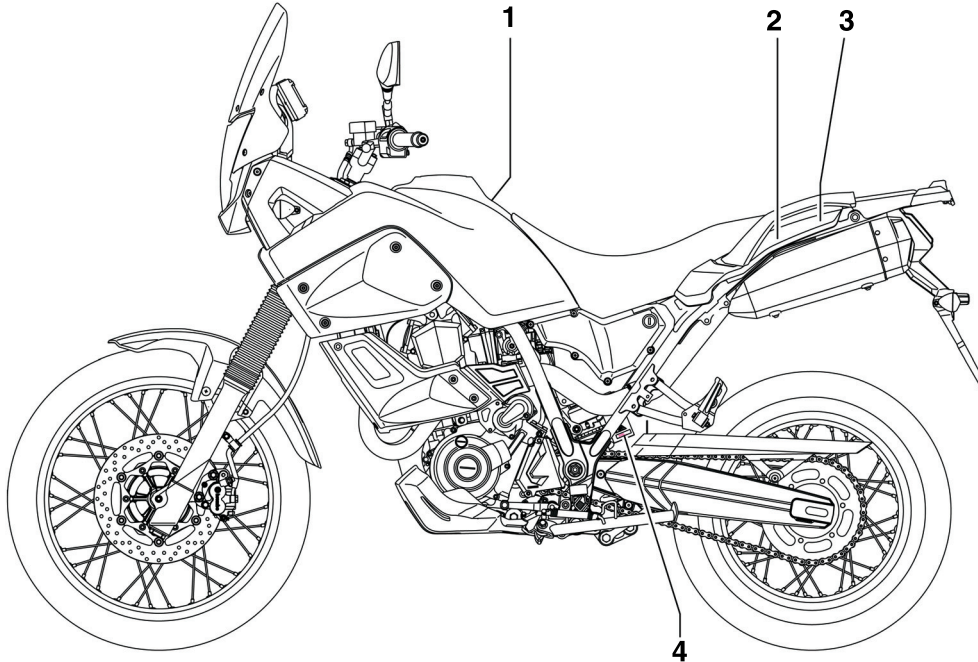



1



# LOCATION OF IMPORTANT LABELS

1

	<ul style="list-style-type: none"><li>● BEFORE YOU OPERATE THIS VEHICLE. READ THE OWNER'S MANUAL.</li><li>● LIRE LE MANUEL DU PROPRIETARE AVANT D'UTILISER CE VEHICULE.</li><li>● LESEN SIE BITTE DIE BEDIENUNGSANLEITUNG BEVOR SIE DIESES FAHRZEUG FAHREN.</li><li>● PRIMA DI USARE IL VEICOLO. LEGGETE IL LIBRETTO USO E MANUTENZIONE.</li><li>● ANTES DE CONDUCIR ESTE VEHICULO. LEER EL MANUAL DEL PROPIETARIO.</li></ul>
	

11D-F1568-00

2

	<ul style="list-style-type: none"><li>● <b>DANGER OF SERIOUS BURNS:</b> DO NOT TOUCH ANY PART (STEEL/OR PLASTIC) UNTIL EXHAUST SYSTEM HAS COOLED. DO NOT PUT ABSOLUTELY ANY OBJECT IN THIS AREA.</li><li>● <b>RISQUE DE GRAVES BRÛLURES:</b> NE TOUCHEZ AUCUNES PIÈCES (CHASSIS ET/OU CARROSSERIE) AVANT QUE LE SYSTÈME D'ÉCHAPPEMENT NE SOIT REFROIDI. NE METTRE ABSOLUMENT AUCUN OBJET À CET ENDROIT.</li><li>● <b>GEFAHR VON REIHE VERBRENNUNGEN:</b> NICHT ANFASSEN (STAHL UND/ODER PLASTIK) BIS WANN DER AUSPUFFGRUPPE NICHT ERKÄLTETEST IST. ABSOLUT KEINEN GEGENSTAND IN DIESE ZONE EINSETZEN.</li><li>● <b>PERICOLO USTIONI SERIE:</b> NON TOCCARE NESSUNA PARTE (ACCIAIO E/O PLASTICA) FINCHÉ IL GR. SCARICO NON SI È RAFFREDDATO. NON METTERE ASSOLUTAMENTE NESSUN OGGETTO IN QUESTA ZONA.</li><li>● <b>PELIGRO INFLAMABLE:</b> NO TOCAR (NI PLASTICO NI METAL) HASTA EL COMPLETO ENFRIAMIENTO DEL TUBO DE ESCAPE. NO DEPOSITAR NINGUN OBJETO EN ESTA AREA.</li></ul>
---	---

11D-F819R-10

3



5YK-F117B-AO

4



# SAFETY INFORMATION

EAU10313

## Be a Responsible Owner

As the vehicle's owner, you are responsible for the safe and proper operation of your motorcycle.

Motorcycles are single-track vehicles. Their safe use and operation are dependent upon the use of proper riding techniques as well as the expertise of the operator. Every operator should know the following requirements before riding this motorcycle.

He or she should:

- Obtain thorough instructions from a competent source on all aspects of motorcycle operation.
- Observe the warnings and maintenance requirements in this Owner's Manual.
- Obtain qualified training in safe and proper riding techniques.
- Obtain professional technical service as indicated in this Owner's Manual and/or when made necessary by mechanical conditions.

## Safe riding

Perform the pre-operation checks each time you use the vehicle to make sure it is in safe operating condition. Failure to inspect or maintain the vehicle properly increases the possibility of an accident or equipment damage. See page 5-2 for a list of pre-operation checks.

- This motorcycle is designed to carry the operator and a passenger.
- The failure of motorists to detect and recognize motorcycles in traffic is the predominating cause of automobile/motorcycle accidents. Many accidents have been caused by an automobile driver who did not see the motorcycle. Making yourself conspicuous appears to be very effective in reducing the chance of this type of accident.

### Therefore:

- Wear a brightly colored jacket.
- Use extra caution when you are approaching and passing through intersections, since intersections are the most likely places for motorcycle accidents to occur.

- Ride where other motorists can see you. Avoid riding in another motorist's blind spot.
- Many accidents involve inexperienced operators. In fact, many operators who have been involved in accidents do not even have a current motorcycle license.
- Make sure that you are qualified and that you only lend your motorcycle to other qualified operators.
- Know your skills and limits. Staying within your limits may help you to avoid an accident.
- We recommend that you practice riding your motorcycle where there is no traffic until you have become thoroughly familiar with the motorcycle and all of its controls.
- Many accidents have been caused by error of the motorcycle operator. A typical error made by the operator is veering wide on a turn due to excessive speed or undercornering (insufficient lean angle for the speed).
- Always obey the speed limit and never travel faster than warranted by road and traffic conditions.

# SAFETY INFORMATION

- Always signal before turning or changing lanes. Make sure that other motorists can see you.
- The posture of the operator and passenger is important for proper control.
  - The operator should keep both hands on the handlebar and both feet on the operator footrests during operation to maintain control of the motorcycle.
  - The passenger should always hold onto the operator, the seat strap or grab bar, if equipped, with both hands and keep both feet on the passenger footrests. Never carry a passenger unless he or she can firmly place both feet on the passenger footrests.
- Never ride under the influence of alcohol or other drugs.

## **Protective apparel**

The majority of fatalities from motorcycle accidents are the result of head injuries. The use of a safety helmet is the single most critical factor in the prevention or reduction of head injuries.

- Always wear an approved helmet.
- Wear a face shield or goggles. Wind in your unprotected eyes could contribute to an impairment of vision that could delay seeing a hazard.
- The use of a jacket, heavy boots, trousers, gloves, etc., is effective in preventing or reducing abrasions or lacerations.
- Never wear loose-fitting clothes, otherwise they could catch on the control levers, footrests, or wheels and cause injury or an accident.
- Always wear protective clothing that covers your legs, ankles, and feet. The engine or exhaust system become very hot during or after operation and can cause burns.
- A passenger should also observe the above precautions.

## **Avoid Carbon Monoxide Poisoning**

All engine exhaust contains carbon monoxide, a deadly gas. Breathing carbon monoxide can cause headaches, dizziness, drowsiness, nausea, confusion, and eventually death.

Carbon Monoxide is a colorless, odorless, tasteless gas which may be present even if you do not see or smell any engine exhaust. Deadly levels of carbon monoxide can collect rapidly and you can quickly be overcome and unable to save yourself. Also, deadly levels of carbon monoxide can linger for hours or days in enclosed or poorly ventilated areas. If you experience any symptoms of carbon monoxide poisoning, leave the area immediately, get fresh air, and **SEEK MEDICAL TREATMENT.**

- Do not run engine indoors. Even if you try to ventilate engine exhaust with fans or open windows and doors, carbon monoxide can rapidly reach dangerous levels.
- Do not run engine in poorly ventilated or partially enclosed areas such as barns, garages, or carports.
- Do not run engine outdoors where engine exhaust can be drawn into a building through openings such as windows and doors.

# SAFETY INFORMATION

2

## Loading

Adding accessories or cargo to your motorcycle can adversely affect stability and handling if the weight distribution of the motorcycle is changed. To avoid the possibility of an accident, use extreme caution when adding cargo or accessories to your motorcycle. Use extra care when riding a motorcycle that has added cargo or accessories. Here, along with the information about accessories below, are some general guidelines to follow if loading cargo to your motorcycle:

**The total weight of the operator, passenger, accessories and cargo must not exceed the maximum load limit. Operation of an overloaded vehicle could cause an accident.**

**Maximum load:**  
190 kg (419 lb)

When loading within this weight limit, keep the following in mind:

- Cargo and accessory weight should be kept as low and close to the motorcycle as possible. Se-

curely pack your heaviest items as close to the center of the vehicle as possible and make sure to distribute the weight as evenly as possible on both sides of the motorcycle to minimize imbalance or instability.

- Shifting weights can create a sudden imbalance. Make sure that accessories and cargo are securely attached to the motorcycle before riding. Check accessory mounts and cargo restraints frequently.
  - Properly adjust the suspension for your load, and check the condition and pressure of your tires.
  - Never attach any large or heavy items to the handlebar, front fork, or front fender. These items, including such cargo as sleeping bags, duffel bags, or tents, can create unstable handling or a slow steering response.
- **This vehicle is not designed to pull a trailer or to be attached to a sidecar.**

## Genuine Yamaha Accessories

Choosing accessories for your vehicle is an important decision. Genuine Yamaha accessories, which are available only from a Yamaha dealer, have been designed, tested, and approved by Yamaha for use on your vehicle.

Many companies with no connection to Yamaha manufacture parts and accessories or offer other modifications for Yamaha vehicles. Yamaha is not in a position to test the products that these aftermarket companies produce. Therefore, Yamaha can neither endorse nor recommend the use of accessories not sold by Yamaha or modifications not specifically recommended by Yamaha, even if sold and installed by a Yamaha dealer.

## Aftermarket Parts, Accessories, and Modifications

While you may find aftermarket products similar in design and quality to genuine Yamaha accessories, recognize that some aftermarket accessories or modifications are not suitable because of potential safety hazards to you or others. Installing aftermarket

products or having other modifications performed to your vehicle that change any of the vehicle's design or operation characteristics can put you and others at greater risk of serious injury or death. You are responsible for injuries related to changes in the vehicle.

Keep the following guidelines in mind, as well as those provided under "Loading" when mounting accessories.

- Never install accessories or carry cargo that would impair the performance of your motorcycle. Carefully inspect the accessory before using it to make sure that it does not in any way reduce ground clearance or cornering clearance, limit suspension travel, steering travel or control operation, or obscure lights or reflectors.
- Accessories fitted to the handlebar or the front fork area can create instability due to improper weight distribution or aerodynamic changes. If accessories are added to the handlebar or front fork area, they must be as

lightweight as possible and should be kept to a minimum.

- Bulky or large accessories may seriously affect the stability of the motorcycle due to aerodynamic effects. Wind may attempt to lift the motorcycle, or the motorcycle may become unstable in cross winds. These accessories may also cause instability when passing or being passed by large vehicles.
- Certain accessories can displace the operator from his or her normal riding position. This improper position limits the freedom of movement of the operator and may limit control ability, therefore, such accessories are not recommended.
- Use caution when adding electrical accessories. If electrical accessories exceed the capacity of the motorcycle's electrical system, an electric failure could result, which could cause a dangerous loss of lights or engine power.

### **Aftermarket Tires and Rims**

The tires and rims that came with your motorcycle were designed to match the performance capabilities and to provide the best combination of handling, braking, and comfort. Other tires, rims, sizes, and combinations may not be appropriate. Refer to page 7-16 for tire specifications and more information on replacing your tires.

# DESCRIPTION

EAU10410

## Left view

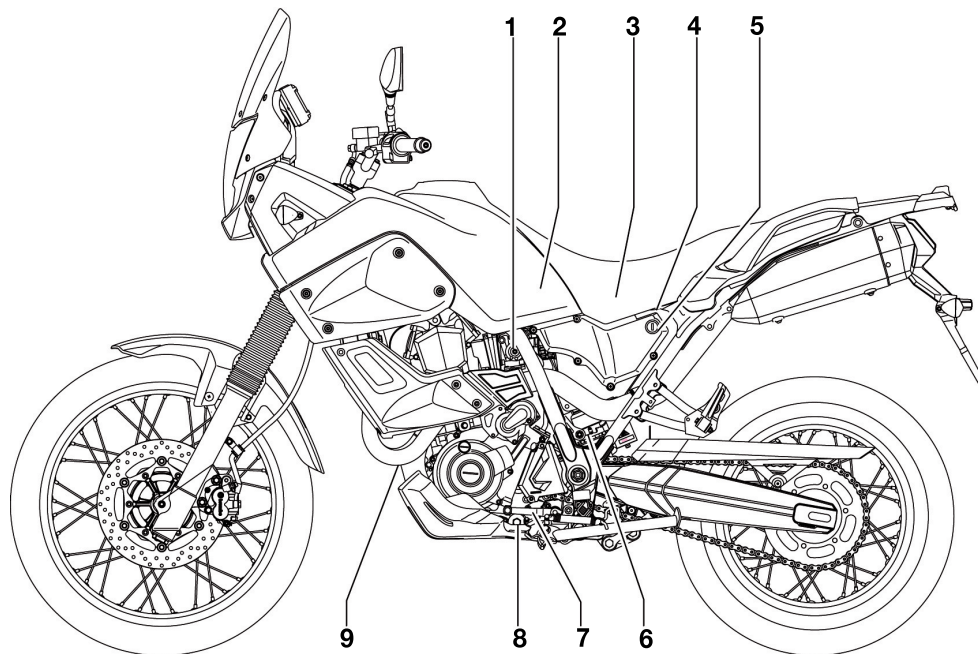

1. Idle adjusting screw (page 7-15)
2. Owner's tool kit (page 7-1)
3. Air filter element (page 7-14)
4. Fuse box (page 7-31)
5. Seat lock (page 4-14)

6. Shock absorber assembly/spring preload adjusting ring (page 4-16)
7. Shift pedal (page 4-10)
8. Engine oil drain bolt (crankcase) (page 7-10)
9. Engine oil drain bolt (oil tank) (page 7-10)

## Right view

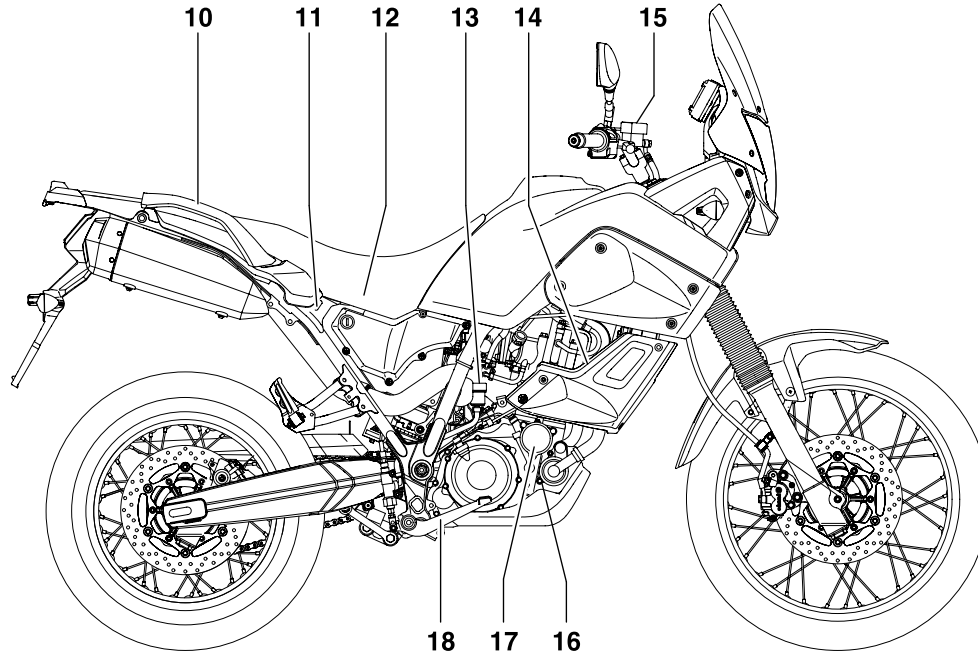

- 10. Grab bar
- 11. Main fuse (page 7-31)
- 12. Battery (page 7-30)
- 13. Rear brake fluid reservoir (page 7-22)
- 14. Coolant reservoir (page 7-13)

- 15. Front brake fluid reservoir (page 7-22)
- 16. Coolant drain bolt (page 7-12)
- 17. Engine oil filter element (page 7-11)
- 18. Brake pedal (page 4-11)

# DESCRIPTION

EAU10430

## Controls and instruments

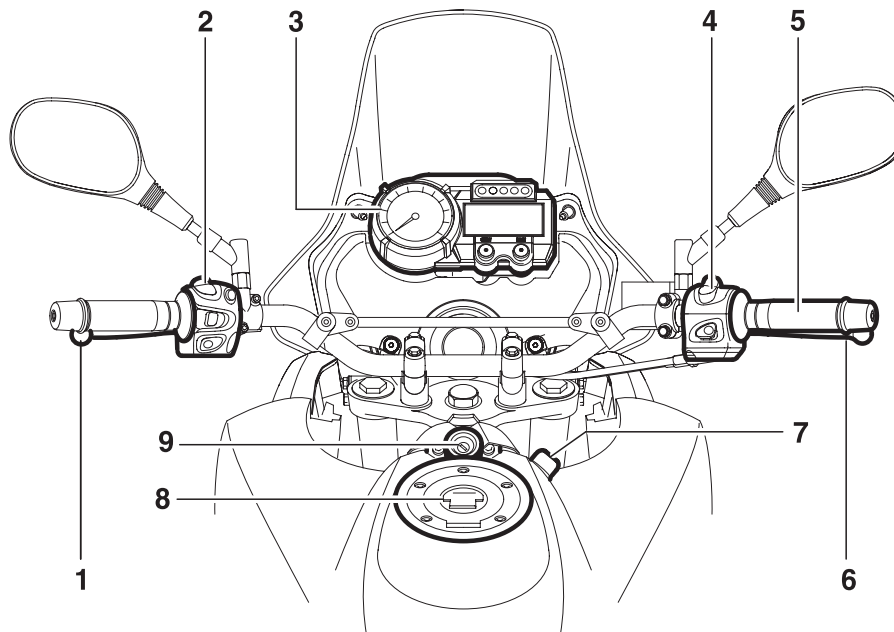

1. Clutch lever (page 4-10)

2. Left handlebar switches (page 4-9)

3. Multi-function meter unit and warning lights (page 4-3, 4-5)

4. Right handlebar switches (page 4-9)

5. Throttle grip (page 7-16)

6. Brake lever (page 4-11)

7. Engine oil filler cap/dipstick (page 7-9)

8. Fuel tank cap (page 4-11)

9. Main switch and steering lock (page 4-2)



EAU10976

## Immobilizer system

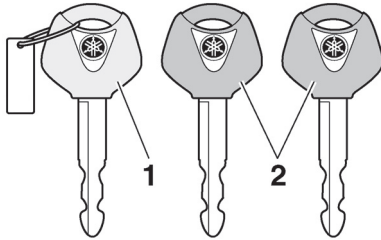

1. Code re-registering key (red bow)
2. Standard keys (black bow)

This vehicle is equipped with an immobilizer system to help prevent theft by re-registering codes in the standard keys. This system consists of the following.

- a code re-registering key (with a red bow)
- two standard keys (with a black bow) that can be re-registered with new codes
- a transponder (which is installed in the code re-registering key)
- an immobilizer unit
- an ECU

- an immobilizer system indicator light (See page 4-3.)

The key with the red bow is used to register codes in each standard key. Since re-registering is a difficult process, take the vehicle along with all three keys to a Yamaha dealer to have them re-registered. Do not use the key with the red bow for driving. It should only be used for re-registering the standard keys. Always use a standard key for driving.

### NOTICE

ECA11821

- **DO NOT LOSE THE CODE RE-REGISTERING KEY! CONTACT YOUR DEALER IMMEDIATELY IF IT IS LOST!** If the code re-registering key is lost, registering new codes in the standard keys is impossible. The standard keys can still be used to start the vehicle, however if code re-registering is required (i.e., if a new standard key is made or all keys are lost) the entire immobilizer system must be replaced. Therefore, it is highly recommended to use either standard

key and keep the code re-registering key in a safe place.

- Do not submerge any key in water.
- Do not expose any key to excessively high temperatures.
- Do not place any key close to magnets (this includes, but not limited to, products such as speakers, etc.).
- Do not place items that transmit electrical signals close to any key.
- Do not place heavy items on any key.
- Do not grind any key or alter its shape.
- Do not disassemble the plastic part of any key.
- Do not put two keys of any immobilizer system on the same key ring.
- Keep the standard keys as well as keys of other immobilizer systems away from this vehicle's code re-registering key.
- Keep other immobilizer system keys away from the main switch as they may cause signal interference.

# INSTRUMENT AND CONTROL FUNCTIONS

EAU10471

## Main switch/steering lock

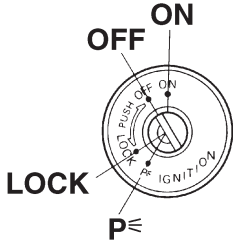

4

The main switch/steering lock controls the ignition and lighting systems, and is used to lock the steering.

### TIP

Be sure to use the standard key (black bow) for regular use of the vehicle. To minimize the risk of losing the code re-registering key (red bow), keep it in a safe place and only use it for code re-registering.

### ON

All electrical circuits are supplied with power, the meter lighting, taillight, license plate light and auxiliary lights come on, and the engine can be started. The key cannot be removed.

### TIP

The headlights come on automatically when the engine is started and stay on until the key is turned to "OFF", even if the engine stalls.

### OFF

All electrical systems are off. The key can be removed.

### **! WARNING**

**Never turn the key to "OFF" or "LOCK" while the vehicle is moving. Otherwise the electrical systems will be switched off, which may result in loss of control or an accident.**

EAU10550

### LOCK

The steering is locked, and all electrical systems are off. The key can be removed.

### To lock the steering

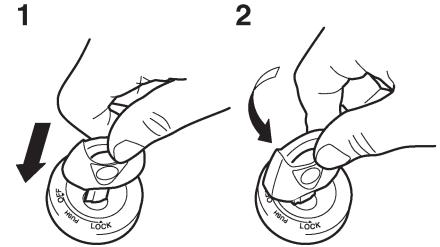

1. Push
2. Turn

1. Turn the handlebars all the way to the left or right.
2. Push the key in from the "OFF" position, and then turn it to "LOCK" while still pushing it.
3. Remove the key.

EAU10691

EAU10661

EWA10061

# INSTRUMENT AND CONTROL FUNCTIONS

## To unlock the steering

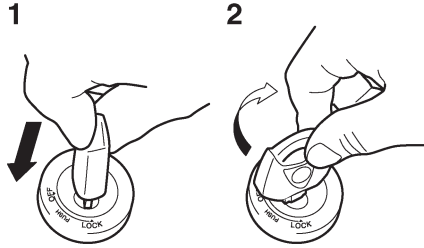

1. Push
2. Turn

Push the key into the main switch, and then turn it to "OFF" while still pushing it.

## P<sup>c</sup> (Parking)

The steering is locked, and the tail-light, license plate light and auxiliary lights are on. The hazard lights and turn signal lights can be turned on, but all other electrical systems are off. The key can be removed.

The steering must be locked before the key can be turned to "P<sup>c</sup>".

### NOTICE

**Do not use the parking position for an extended length of time, otherwise the battery may discharge.**

EAU10941

ECA11020

EAU11004

## Indicator and warning lights

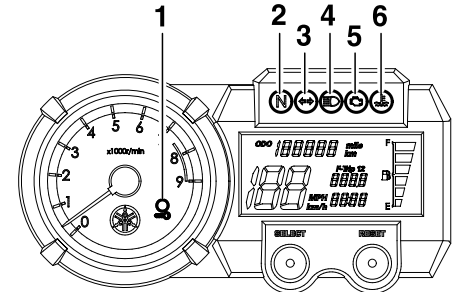

1. Immobilizer system indicator light "⚡"
2. Neutral indicator light "N"
3. Turn signal indicator light "↔"
4. High beam indicator light "≡"
5. Engine trouble warning light "🔧"
6. Coolant temperature warning light "🌡"

## Turn signal indicator light "↔"

This indicator light flashes when the turn signal switch is pushed to the left or right.

The electrical circuit of the turn signal indicator light can be checked by turning the key to "ON".

If the indicator light does not come on for a few seconds, then go off, have a Yamaha dealer check the electrical circuit.

EAUB1510

# INSTRUMENT AND CONTROL FUNCTIONS

## Neutral indicator light “N”

EAUB1520

This indicator light comes on when the transmission is in the neutral position. The electrical circuit of the neutral indicator light can be checked by turning the key to "ON". If the indicator light does not come on for a few seconds, then go off, have a Yamaha dealer check the electrical circuit.

## High beam indicator light “”

EAUB1530

This indicator light comes on when the high beam of the headlight is switched on. The electrical circuit of the high beam indicator light can be checked by turning the key to "ON". If the indicator light does not come on for a few seconds, then go off, have a Yamaha dealer check the electrical circuit.

## Coolant temperature warning light “”

EAU11444

This warning light comes on if the engine overheats. If this occurs, stop the engine immediately and allow the engine to cool. The electrical circuit of the warning light can be checked by turning the key to "ON". The warning light should come on for a few seconds,

and then go off. If the warning light does not come on initially when the key is turned to "ON", or if the warning light remains on, have a Yamaha dealer check the electrical circuit.

### NOTICE

ECA10021

**Do not continue to operate the engine if it is overheating.**

### TIP

- For radiator-fan-equipped vehicles, the radiator fan(s) automatically switch on or off according to the coolant temperature in the radiator.
- If the engine overheats, see page 7-41 for further instructions.

## Engine trouble warning light “”

EAU11534

This warning light comes on or flashes if a problem is detected in the electrical circuit monitoring the engine. If this occurs, have a Yamaha dealer check the self-diagnosis system. (See page 4-8 for an explanation of the self-diagnosis device.) The electrical circuit of the warning light can be checked by

turning the key to "ON". The warning light should come on for a few seconds, and then go off. If the warning light does not come on initially when the key is turned to "ON", or if the warning light remains on, have a Yamaha dealer check the electrical circuit.

EAU26876

## Immobilizer system indicator light “”

The electrical circuit of the indicator light can be checked by turning the key to "ON". The indicator light should come on for a few seconds, and then go off. If the indicator light does not come on initially when the key is turned to "ON", or if the indicator light remains on, have a Yamaha dealer check the electrical circuit.

When the key is turned to "OFF" and 30 seconds have passed, the indicator light will start flashing indicating the immobilizer system is enabled. After 24 hours have passed, the indicator light will stop flashing, however the immobilizer system is still enabled.

This model is also equipped with a self-diagnosis device for the immobilizer system. (See page 4-8 for an explanation of the self-diagnosis device.)

# INSTRUMENT AND CONTROL FUNCTIONS

## Multi-function display

EAUB1501

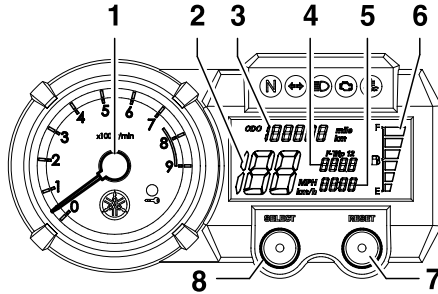

1. Tachometer
2. Speedometer
3. Odometer
4. Tripmeters/Fuel reserve tripmeter
5. Clock
6. Fuel meter
7. "RESET" button
8. "SELECT" button

### **WARNING**

EWA12311

Be sure to stop the vehicle before making any setting changes to the multi-function display.

The multi-function display is equipped with the following:

- a speedometer (which shows the riding speed)
- a digital tachometer (which shows engine r/min)
- an odometer (which shows the total distance traveled)
- two tripmeters (which show the distance traveled since they were last set to zero)
- a fuel reserve tripmeter (which shows the distance traveled since the bottom segment of the fuel meter started flashing)
- a clock
- a fuel meter
- a self-diagnosis device

### TIP

- Be sure to turn the key to "ON" before using the "SELECT" and "RESET" buttons.
- For the U.K. only: To switch the speedometer and odometer/tripmeter displays between kilometers and miles, push the "SELECT" and "RESET" buttons together and turn the key to "ON". When the digits start flashing, push the "SELECT" button to choose kilometers or miles.

# INSTRUMENT AND CONTROL FUNCTIONS

## Tachometer

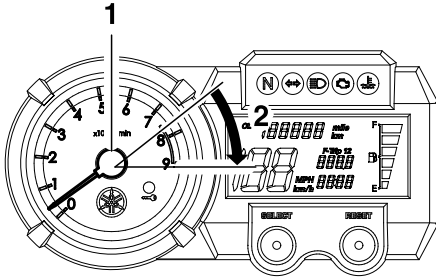

1. Tachometer
2. Red zone

The tachometer allows the rider to monitor the engine speed and keep it within the ideal power range.

When the key is turned to "ON", the tachometer needle will sweep once across the r/min range and then return to zero r/min in order to test the electrical circuit.

### NOTICE

**Do not operate the engine in the tachometer red zone.**

**Red zone: 7,500 r/min and above.**

ECA10030

## Tripmeter and tachometer modes

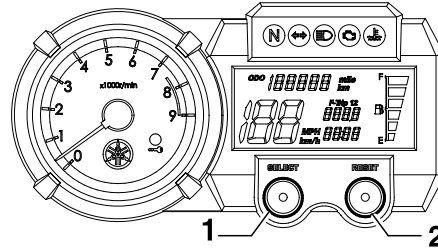

1. "SELECT" button
2. "RESET" button

Pushing the "SELECT" button switches the display between the tripmeter modes "TRIP 1" and "TRIP 2" in the following order:

TRIP 1 → TRIP 2 → TRIP 1

When the fuel amount in the fuel tank decreases to 6.7 L (1.77 US gal) (1.47 Imp.gal), the bottom segment of the fuel meter will start flashing, and the tripmeter display will automatically change to the fuel reserve tripmeter mode "F-TRIP" and start counting the distance traveled from that point. In that case, pushing the "SELECT" but-

ton switches the display between the various tripmeter modes in the following order:

F-TRIP → TRIP 1 → TRIP 2 → F-TRIP

To reset a tripmeter, select it by pushing the "SELECT" button, and then push the "RESET" button for at least four seconds. If you do not reset the fuel reserve tripmeter manually, it will reset itself automatically and the display will return to the prior mode after refueling and traveling 5 km (3 mi).

# INSTRUMENT AND CONTROL FUNCTIONS

## Clock mode

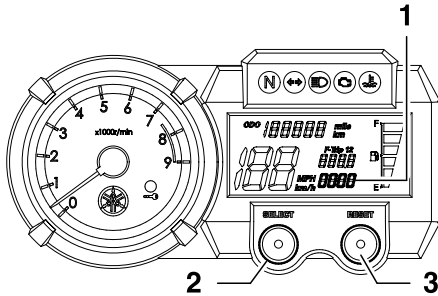

1. Clock
2. "SELECT" button
3. "RESET" button

## TIP

The clock is displayed even when the key is turned to "OFF".

## To set the clock:

1. Push the "SELECT" button for at least four seconds.
2. When the hour digits start flashing, push the "RESET" button to set the hours.
3. Push the "SELECT" button, and the minute digits will start flashing.
4. Push the "RESET" button to set the minutes.
5. Push the "SELECT" button and then release it to start the clock.

## Fuel meter

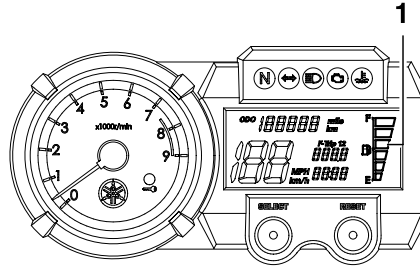

1. Fuel meter

With the key in the "ON" position, the fuel meter indicates the amount of fuel in the fuel tank. When the key is turned to "ON", all of the display segments of the fuel meter will appear one after the other and then disappear in order to test the electrical circuit. The display segments of the fuel meter disappear towards "E" (Empty) as the fuel level decreases. When only one segment is left near "E" (Empty), refuel as soon as possible.

## TIP

This fuel meter is equipped with a self-diagnosis system. If the electrical circuit is defective, all the segments will start flashing. If this occurs, have a Yamaha dealer check the electrical circuit.

# INSTRUMENT AND CONTROL FUNCTIONS

## Self-diagnosis devices

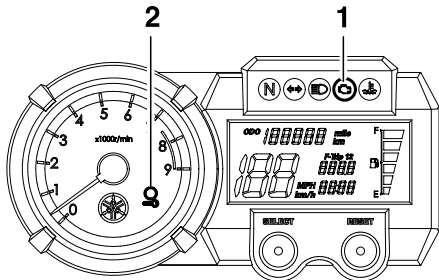

4

1. Engine trouble warning light “”
2. Immobilizer system indicator light “”

This model is equipped with a self-diagnosis device for various electrical circuits.

If any of those circuits are defective, the engine trouble warning light will start flashing. If this occurs, have a Yamaha dealer check the vehicle.

This model is also equipped with a self-diagnosis device for the immobilizer system.

If any of the immobilizer system circuits are defective, the immobilizer system indicator light will start flashing.

If this occurs, have a Yamaha dealer check the vehicle.

## TIP \_\_\_\_\_

If the indicator light slowly flashes five times, and then quickly flashes two times repeatedly, this error could be caused by transponder interference. If this occurs, try the following.

1. Use the code re-registering key to start the engine.

## TIP \_\_\_\_\_

Make sure there are no other immobilizer keys close to the main switch, and do not keep more than one immobilizer key on the same key ring! Immobilizer system keys may cause signal interference, which may prevent the engine from starting.

2. If the engine starts, turn it off, and try starting the engine with the standard keys.
3. If one or both of the standard keys do not start the engine, take the vehicle, the code re-registering key and both standard keys to a Yamaha dealer and have the standard keys re-registered.

If the immobilizer system indicator light continues to flash, have a Yamaha dealer check the vehicle.



# INSTRUMENT AND CONTROL FUNCTIONS

EAU12348

## Handlebar switches

### Left

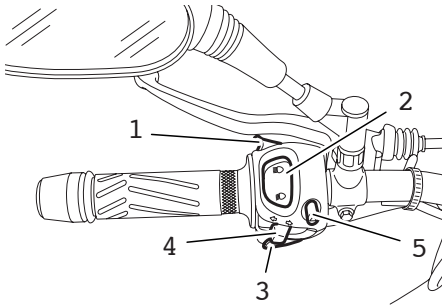

1. Pass switch “”
3. Horn switch “”
5. Hazard switch “

### Right

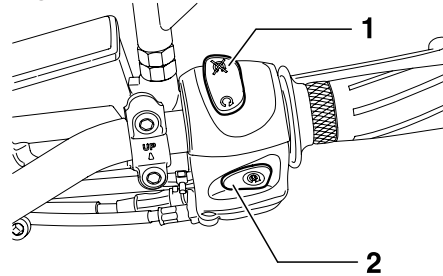

1. Engine stop switch “”

### Pass switch “ Press this switch to flash the headlight.

EAU12350

### Dimmer switch “ Set this switch to “” for the low beam.

EAU12400

### Turn signal switch “ To signal a right-hand turn, push this switch to “”. When released, the switch returns to the center position. To cancel the turn signal lights, push the switch in after it has returned to the center position.

EAU12460

### Horn switch “ Press this switch to sound the horn.

EAU12500

### Engine stop switch “ Set this switch to “” to stop the engine in case of an emergency, such as when the motorcycle overturns or when the throttle cable is stuck.

EAU12660

### Start switch “ Push this switch to crank the engine with the starter. See page 6-1 for starting instructions prior to starting the engine.

EAU12711

# INSTRUMENT AND CONTROL FUNCTIONS

EAU12733

## Hazard switch “”

With the key in the “ON” or  $P^{\frac{2}{2}}$  position, use this switch to turn on the hazard lights (simultaneous flashing of all turn signal lights).

The hazard lights are used in case of an emergency or to warn other drivers when your vehicle is stopped where it might be a traffic hazard.

ECA10061

### NOTICE

**Do not use the hazard lights for an extended length of time with the engine not running, otherwise the battery may discharge.**

EAU12820

## Clutch lever

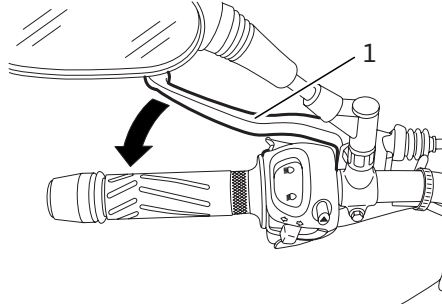

1. Clutch lever

The clutch lever is located at the left handlebar grip. To disengage the clutch, pull the lever toward the handlebar grip. To engage the clutch, release the lever. The lever should be pulled rapidly and released slowly for smooth clutch operation.

The clutch lever is equipped with a clutch switch, which is part of the ignition circuit cut-off system. (See page 4-17).

EAU12870

## Shift pedal

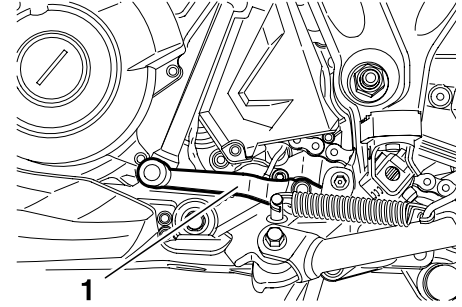

1. Shift pedal

The shift pedal is located on the left side of the engine and is used in combination with the clutch lever when shifting the gears of the 5-speed constant-mesh transmission equipped on this motorcycle.

EAU26823

## Brake lever

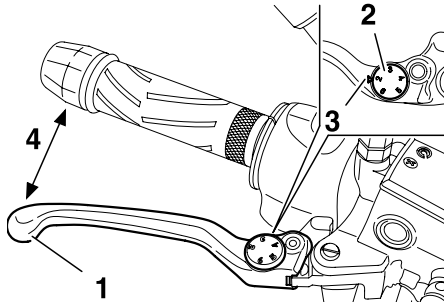

1. Brake lever
2. Position adjusting dial
3. Arrow mark
4. Distance

The brake lever is located at the right handlebar grip. To apply the front brake, pull the lever toward the handlebar grip.

The brake lever is equipped with a position adjusting dial. To adjust the distance between the brake lever and the handlebar grip, turn the adjusting dial while holding the lever pushed away from the handlebar grip. Make sure that the appropriate setting on the adjusting dial is aligned with the “▶” mark on the brake lever.

EAU12941

## Brake pedal

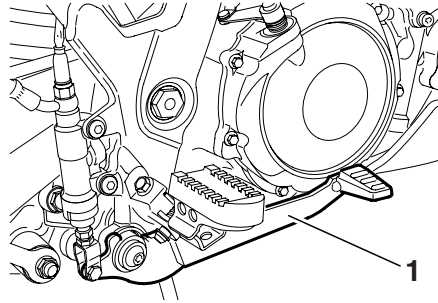

1. Brake pedal

The brake pedal is on the right side of the motorcycle. To apply the rear brake, press down on the brake pedal.

EAU13074

## Fuel tank cap

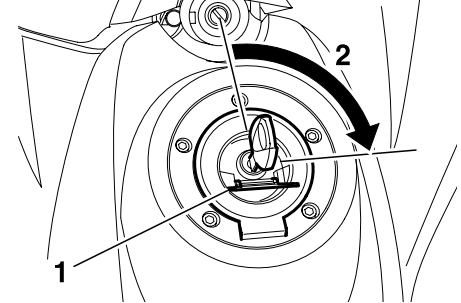

1. Lock cover
2. Open

### To open the fuel tank cap

Open the fuel tank cap lock cover, insert the key into the lock, and then turn it 1/4 turn clockwise. The lock will be released and the fuel tank cap can be opened.

# INSTRUMENT AND CONTROL FUNCTIONS

## To close the fuel tank cap

1. Push the fuel tank cap into position with the key inserted in the lock.
2. Turn the key counterclockwise to the original position, remove it, and then close the lock cover.

## TIP

The fuel tank cap cannot be closed unless the key is in the lock. In addition, the key cannot be removed if the cap is not properly closed and locked.

## WARNING

EWA11091

**Make sure that the fuel tank cap is properly closed after filling fuel. Leaking fuel is a fire hazard.**

## Fuel

Make sure there is sufficient gasoline in the tank.

## WARNING

**Gasoline and gasoline vapors are extremely flammable. To avoid fires and explosions and to reduce the risk of injury when refueling, follow these instructions.**

1. Before refueling, turn off the engine and be sure that no one is sitting on the vehicle. Never refuel while smoking, or while in the vicinity of sparks, open flames, or other sources of ignition such as the pilot lights of water heaters and clothes dryers.
2. Do not overfill the fuel tank. When refueling, be sure to insert the pump nozzle into the fuel tank filler hole. Stop filling when the fuel reaches the bottom of the filler tube. Because fuel expands when it heats up, heat from the engine or the sun can cause fuel to spill out of the fuel tank.

EAU13221

EWA10881

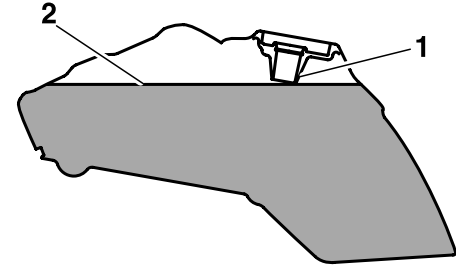

1. Fuel tank filler tube
2. Fuel level

3. Wipe up any spilled fuel immediately. **NOTICE: Immediately wipe off spilled fuel with a clean, dry, soft cloth, since fuel may deteriorate painted surfaces or plastic parts.**
4. Be sure to securely close the fuel tank cap.

## WARNING

EWA15151

**Gasoline is poisonous and can cause injury or death. Handle gasoline with care. Never siphon gasoline by mouth. If you should swallow some gasoline or inhale a lot of gasoline vapor, or get some gasoline in your eyes, see your doctor immediately. If gasoline spills on**

# INSTRUMENT AND CONTROL FUNCTIONS

your skin, wash with soap and water. If gasoline spills on your clothing, change your clothes.

EAU13390

**Recommended fuel:**  
PREMIUM UNLEADED  
GASOLINE ONLY

**Fuel tank capacity:**  
23.0 L (6.07 US gal) (5.05 Imp.gal)

**Fuel reserve amount (when the  
fuel level warning light comes on):**  
6.7 L (1.77 US gal) (1.47 Imp.gal)

ECA11400

## NOTICE

**Use only unleaded gasoline. The use of leaded gasoline will cause severe damage to internal engine parts, such as the valves and piston rings, as well as to the exhaust system.**

Your Yamaha engine has been designed to use premium unleaded gasoline with a research octane number of 95 or higher. If knocking (or pinging) occurs, use a gasoline of a different brand. Use of unleaded fuel will extend spark plug life and reduce maintenance costs.

## Fuel tank breather/overflow hose

EAUB1300

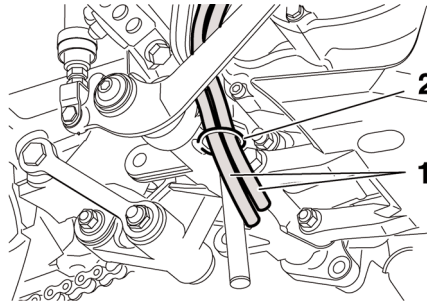

1. Fuel tank breather/hose
2. Hose clamp

Before operating the motorcycle:

- Check the fuel tank breather/overflow hose connection.
- Check the fuel tank breather/overflow hose for cracks or damage, and replace it if damaged.
- Make sure that the end of the fuel tank breather/overflow hose is not blocked, and clean it if necessary.
- Make sure that the end of the fuel tank breather/overflow hose is positioned inside of the clamp.

4-13

EAU13433

## Catalytic converters

This vehicle is equipped with catalytic converters in the exhaust system.

EWA10862

## **⚠ WARNING**

The exhaust system is hot after operation. To prevent a fire hazard or burns:

- Do not park the vehicle near possible fire hazards such as grass or other materials that easily burn.
- Park the vehicle in a place where pedestrians or children are not likely to touch the hot exhaust system.
- Make sure that the exhaust system has cooled down before doing any maintenance work.
- Do not allow the engine to idle more than a few minutes. Long idling can cause a build-up of heat.

# INSTRUMENT AND CONTROL FUNCTIONS

ECA10701

EAU32980

## NOTICE

Use only unleaded gasoline. The use of leaded gasoline will cause unreparable damage to the catalytic converter.

## Seat

### To remove the seat

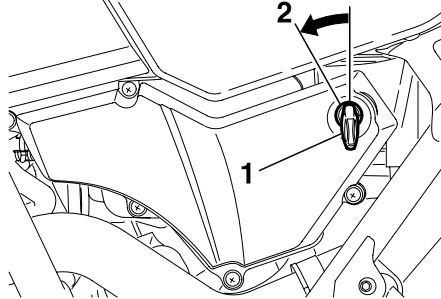

1. Seat lock
2. Unlock

1. Insert the key into the seat lock, and then turn it counterclockwise.
2. While holding the key in that position, lift the rear of the seat up, and then pull the seat off.

### To install the seat

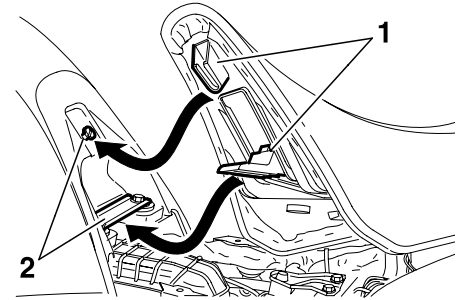

1. Projections
2. Seat holders

1. Insert the projection on the front of the seat into the seat holder as shown.
2. Push the rear of the seat down to lock it in place.
3. Remove the key.

## TIP

Make sure that the seat is properly secured before riding.

EAUB1550

## Adjusting the front fork

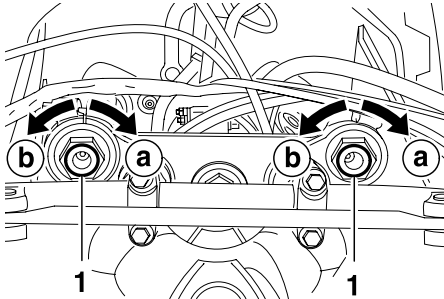

1. Spring preload adjusting bolt  
(a) Increasing the spring preload  
(b) Decreasing the spring preload

This front fork is equipped with spring preload adjusting bolt.

EWA10180

### **⚠ WARNING**

**Always adjust both fork legs equally, otherwise poor handling and loss of stability may result.**

Adjust the spring preload as follows. To increase the spring preload and thereby harden the suspension, turn the adjusting bolts on each fork leg in direction (a). To decrease the spring preload and thereby soften the suspension, turn the adjusting bolts on each fork leg in direction (b).

### **TIP**

Use the 10 mm hexagon wrench included in the owner's tool kit to turn the adjusting bolts.

Maximum (hard):

0 complete turns in direction (b)\*

Standard:

22 complete turns in direction (b)\*

Minimum (soft):

27 complete turns in direction (b)\*

\* With the adjusting bolt fully turned in direction (a)

# INSTRUMENT AND CONTROL FUNCTIONS

EAUB1461

## Adjusting the shock absorber assembly

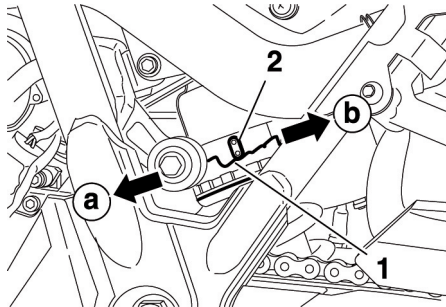

1. Spring preload adjusting ring
  2. Position indicator
- (a) Increasing the spring preload  
(b) Decreasing the spring preload

This shock absorber assembly is equipped with a spring preload adjusting ring.

### NOTICE

ECA10100

**Never attempt to turn an adjusting mechanism beyond the maximum or minimum settings.**

Adjust the spring preload as follows. To increase the spring preload and thereby harden the suspension, turn the adjusting ring in direction (a). To decrease the spring preload and thereby soften the suspension, turn the adjusting ring in direction (b).

### TIP

Align the appropriate notch in the adjusting ring with the position indicator on the shock absorber.

### WARNING

EWAB0020

**Never adjust the spring preload until the exhaust system has cooled down.**

#### Spring preload setting:

- Minimum (soft):  
1
- Standard:  
2
- Maximum (hard):  
9

EWA10221

### WARNING

**This shock absorber assembly contains highly pressurized nitrogen gas. Read and understand the following information before handling the shock absorber assembly.**

- Do not tamper with or attempt to open the cylinder assembly.
- Do not subject the shock absorber assembly to an open flame or other high heat source. This may cause the unit to explode due to excessive gas pressure.
- Do not deform or damage the cylinder in any way. Cylinder damage will result in poor damping performance.
- Do not dispose of a damaged or worn-out shock absorber assembly yourself. Take the shock absorber assembly to a Yamaha dealer for any service.



EAU15301

EWA10240

EAU15314

## Sidestand

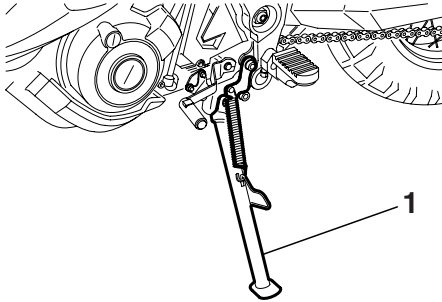

1. Sidestand

The sidestand is located on the left side of the frame. Raise the sidestand or lower it with your foot while holding the motorcycle upright.

### TIP

The built-in sidestand switch is part of the ignition circuit cut-off system, which cuts the ignition in certain situations. (See further down for an explanation of the ignition circuit cut-off system.)

### **⚠ WARNING**

The vehicle must not be ridden with the sidestand down, or if the sidestand cannot be properly moved up (or does not stay up), otherwise the sidestand could contact the ground and distract the operator, resulting in a possible loss of control. Yamaha's ignition circuit cut-off system has been designed to assist the operator in fulfilling the responsibility of raising the sidestand before starting off. Therefore, check this system regularly as described below and have a Yamaha dealer repair it if it does not function properly.

## Ignition circuit cut-off system

The ignition circuit cut-off system (comprising the sidestand switch, clutch switch and neutral switch) has the following functions.

- It prevents starting when the transmission is in gear and the sidestand is up, but the clutch lever is not pulled.
- It prevents starting when the transmission is in gear and the clutch lever is pulled, but the sidestand is still down.
- It cuts the running engine when the transmission is in gear and the sidestand is moved down.

Periodically check the operation of the ignition circuit cut-off system according to the following procedure.

### TIP

This check is most reliable if performed with a warmed-up engine.

# INSTRUMENT AND CONTROL FUNCTIONS

With the engine turned off:

1. Move the sidestand down.
2. Make sure that the engine stop switch is set to "O".
3. Turn the key on.
4. Shift the transmission into the neutral position.
5. Push the start switch.

**Does the engine start?**

YES

NO

With the engine still running:

6. Move the sidestand up.
7. Keep the clutch lever pulled.
8. Shift the transmission into gear.
9. Move the sidestand down.

**Does the engine stall?**

YES

NO

After the engine has stalled:

10. Move the sidestand up.
11. Keep the clutch lever pulled.
12. Push the start switch.

**Does the engine start?**

YES

NO

The system is OK. **The motorcycle can be ridden.**

## WARNING

**If a malfunction is noted, have a Yamaha dealer check the system before riding.**

The neutral switch may not be working correctly.

**The motorcycle should not be ridden** until checked by a Yamaha dealer.

The sidestand switch may not be working correctly.

**The motorcycle should not be ridden** until checked by a Yamaha dealer.

The clutch switch may not be working correctly.

**The motorcycle should not be ridden** until checked by a Yamaha dealer.

4

# FOR YOUR SAFETY – PRE-OPERATION CHECKS

---

EAU15596

Inspect your vehicle each time you use it to make sure the vehicle is in safe operating condition. Always follow the inspection and maintenance procedures and schedules described in the Owner's Manual.

## **WARNING**

EWA11151

**Failure to inspect or maintain the vehicle properly increases the possibility of an accident or equipment damage. Do not operate the vehicle if you find any problem. If a problem cannot be corrected by the procedures provided in this manual, have the vehicle inspected by a Yamaha dealer.**

---

# FOR YOUR SAFETY - PRE-OPERATION CHECKS

EAU15605

Before using this vehicle, check the following points:

ITEM	CHECKS	PAGE
<b>Fuel</b>	<ul style="list-style-type: none"><li>• Check fuel level in fuel tank.</li><li>• Refuel if necessary.</li><li>• Check fuel line for leakage.</li><li>• Check the fuel tank breather/overflow hose for obstructions, cracks or damage, and check the hose connection.</li></ul>	4-12, 4-13
<b>Engine oil</b>	<ul style="list-style-type: none"><li>• Check oil level in oil tank.</li><li>• If necessary, add recommended oil to specified level.</li><li>• Check vehicle for oil leakage.</li></ul>	7-9
<b>Coolant</b>	<ul style="list-style-type: none"><li>• Check coolant level in reservoir.</li><li>• If necessary, add recommended coolant to specified level.</li><li>• Check cooling system for leakage.</li></ul>	7-12
<b>Front brake</b>	<ul style="list-style-type: none"><li>• Check operation.</li><li>• If soft or spongy, have Yamaha dealer bleed hydraulic system.</li><li>• Check brake pads for wear.</li><li>• Replace if necessary.</li><li>• Check fluid level in reservoir.</li><li>• If necessary, add recommended brake fluid to specified level.</li><li>• Check hydraulic system for leakage.</li></ul>	4-11, 7,21, 7-22, 7-26
<b>Rear brake</b>	<ul style="list-style-type: none"><li>• Check operation.</li><li>• If soft or spongy, have Yamaha dealer bleed hydraulic system.</li><li>• Check brake pads for wear.</li><li>• Replace if necessary.</li><li>• Check fluid level in reservoir.</li><li>• If necessary, add recommended brake fluid to specified level.</li><li>• Check hydraulic system for leakage.</li></ul>	4-11, 7,21, 7-22, 7-27

# FOR YOUR SAFETY – PRE-OPERATION CHECKS

ITEM	CHECKS	PAGE
<b>Clutch</b>	<ul style="list-style-type: none"> <li>• Check operation.</li> <li>• Lubricate cable if necessary.</li> <li>• Check lever free play.</li> <li>• Adjust if necessary.</li> </ul>	4-10, 7-20, 7-26
<b>Throttle grip</b>	<ul style="list-style-type: none"> <li>• Make sure that operation is smooth.</li> <li>• Check cable free play.</li> <li>• If necessary, have Yamaha dealer adjust cable free play and lubricate cable and grip housing.</li> </ul>	7-16, 7-26
<b>Control cables</b>	<ul style="list-style-type: none"> <li>• Make sure that operation is smooth.</li> <li>• Lubricate if necessary.</li> </ul>	7-25
<b>Drive chain</b>	<ul style="list-style-type: none"> <li>• Check chain slack.</li> <li>• Adjust if necessary.</li> <li>• Check chain condition.</li> <li>• Lubricate if necessary.</li> </ul>	7-23, 7-24, 7-25
<b>Wheels and tires</b>	<ul style="list-style-type: none"> <li>• Check for damage.</li> <li>• Check tire condition and tread depth.</li> <li>• Check air pressure.</li> <li>• Correct if necessary.</li> </ul>	7-16, 7-19
<b>Brake and shift pedals</b>	<ul style="list-style-type: none"> <li>• Make sure that operation is smooth.</li> <li>• Lubricate pedal pivoting points if necessary.</li> </ul>	7-27
<b>Brake and clutch levers</b>	<ul style="list-style-type: none"> <li>• Make sure that operation is smooth.</li> <li>• Lubricate lever pivoting points if necessary.</li> </ul>	7-26
<b>Sidestand</b>	<ul style="list-style-type: none"> <li>• Make sure that operation is smooth.</li> <li>• Lubricate pivot if necessary.</li> </ul>	7-27
<b>Chassis fasteners</b>	<ul style="list-style-type: none"> <li>• Make sure that all nuts, bolts and screws are properly tightened.</li> <li>• Tighten if necessary.</li> </ul>	–

# FOR YOUR SAFETY – PRE-OPERATION CHECKS

---

---

ITEM	CHECKS	PAGE
<b>Instruments, lights, signals and switches</b>	<ul style="list-style-type: none"><li>• Check operation.</li><li>• Correct if necessary.</li></ul>	4-3, 4-9
<b>Sidestand switch</b>	<ul style="list-style-type: none"><li>• Check operation of ignition circuit cut-off system.</li><li>• If system is not working correctly, have Yamaha dealer check vehicle.</li></ul>	4-17

# OPERATION AND IMPORTANT RIDING POINTS

EAU15951

Read the Owner's Manual carefully to become familiar with all controls. If there is a control or function you do not understand, ask your Yamaha dealer.

## **WARNING**

EWA10271

**Failure to familiarize yourself with the controls can lead to loss of control, which could cause an accident or injury.**

EAU48020

## **TIP** \_\_\_\_\_

This model is equipped with a lean angle sensor to stop the engine in case of a turnover. In this case, the multi-function display indicates error code 30, but this is not a malfunction. Turn the key to "OFF" and then to "ON" to clear the error code. Failing to do so will prevent the engine from starting even though the engine will crank when pushing the start switch.

EAUB1570

## **Starting the engine**

In order for the ignition circuit cut-off system to enable starting, one of the following conditions must be met:

- The transmission is in the neutral position.
- The transmission is in gear with the clutch lever pulled and the sidestand up.

EWA10290

## **WARNING**

- **Before starting the engine, check the function of the ignition circuit cut-off system according to the procedure described on page 4-18.**
- **Never ride with the sidestand down.**

1. Turn the key to "ON" and make sure that the engine stop switch is set to "O".

# OPERATION AND IMPORTANT RIDING POINTS

ECAB0070

## NOTICE

The following warning lights and indicator lights should come on for a few seconds, then go off.

- Neutral indicator light
- Turn signal indicator light
- High beam indicator light
- Engine trouble warning light
- Coolant temperature warning light
- Immobilizer system indicator light

6

If a warning or indicator light does not go off, see page 4-3 for the corresponding warning and indicator light circuit check.

2. Shift the transmission into the neutral position.

## TIP

When the transmission is in the neutral position, the neutral indicator light should be on, otherwise have a Yamaha dealer check the electrical circuit.

3. Start the engine by pushing the start switch.

## TIP

If the engine fails to start, release the start switch, wait a few seconds, and then try again. Each starting attempt should be as short as possible to preserve the battery. Do not crank the engine more than 10 seconds on any one attempt.

## NOTICE

ECA11040

**For maximum engine life, never accelerate hard when the engine is cold!**

## TIP

The engine is warm when it quickly responds to the throttle.

EAU16671

## Shifting

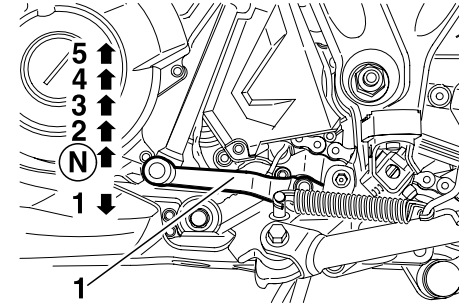

1. Shift pedal  
N. Neutral position

Shifting gears lets you control the amount of engine power available for starting off, accelerating, climbing hills, etc.

The gear positions are shown in the illustration.

## TIP

To shift the transmission into the neutral position, press the shift pedal repeatedly until it reaches the end of its travel, and then slightly raise it.



## CAUTION:

ECA10260

- **Even with the transmission in the neutral position, do not coast for long periods of time with the engine off, and do not tow the motorcycle for long distances. The transmission is properly lubricated only when the engine is running. Inadequate lubrication may damage the transmission.**
- **Always use the clutch while changing gears to avoid damaging the engine, transmission, and drive train, which are not designed to withstand the shock of forced shifting.**

EAU16810

## Tips for reducing fuel consumption

Fuel consumption depends largely on your riding style. Consider the following tips to reduce fuel consumption:

- Shift up swiftly, and avoid high engine speeds during acceleration.
- Do not rev the engine while shifting down, and avoid high engine speeds with no load on the engine.
- Turn the engine off instead of letting it idle for an extended length of time (e.g., in traffic jams, at traffic lights or at railroad crossings).

EAU16841

## Engine break-in

There is never a more important period in the life of your engine than the period between 0 and 1600 km (1000 mi). For this reason, you should read the following material carefully.

Since the engine is brand new, do not put an excessive load on it for the first 1600 km (1000 mi). The various parts in the engine wear and polish themselves to the correct operating clearances. During this period, prolonged full-throttle operation or any condition that might result in engine overheating must be avoided.

# OPERATION AND IMPORTANT RIDING POINTS

---

## 0-1000 km (0-600 mi)

EAU17101

Avoid prolonged operation above 4500 r/min. **NOTICE:** After 1000 km (600 mi) of operation, the engine oil must be changed, and the oil filter element replaced.

## 1000-1600 km (600-1000 mi)

Avoid prolonged operation above 6000 r/min.

## 1600 km (1000 mi) and beyond

The vehicle can now be operated normally.

### NOTICE

ECA10310

- Keep the engine speed out of the tachometer red zone.
- If any engine trouble should occur during the engine break-in period, immediately have a Yamaha dealer check the vehicle.

## Parking

EAU17213

When parking, stop the engine, and then remove the key from the main switch.

### WARNING

EWA10311

- Since the engine and exhaust system can become very hot, park in a place where pedestrians or children are not likely to touch them and be burned.
- Do not park on a slope or on soft ground, otherwise the vehicle may overturn, increasing the risk of a fuel leak and fire.
- Do not park near grass or other flammable materials which might catch fire.

# PERIODIC MAINTENANCE AND ADJUSTMENT

EAU17241

Periodic inspection, adjustment, and lubrication will keep your vehicle in the safest and most efficient condition possible. Safety is an obligation of the vehicle owner/operator. The most important points of vehicle inspection, adjustment, and lubrication are explained on the following pages.

The intervals given in the periodic maintenance and lubrication chart should be simply considered as a general guide under normal riding conditions. However, depending on the weather, terrain, geographical location, and individual use, the maintenance intervals may need to be shortened.

EWA10321

## **! WARNING**

**Failure to properly maintain the vehicle or performing maintenance activities incorrectly may increase your risk of injury or death during service or while using the vehicle. If you are not familiar with vehicle service, have a Yamaha dealer perform service.**

EWA15121

## **! WARNING**

**Turn off the engine when performing maintenance unless otherwise specified.**

**A running engine has moving parts that can catch on body parts or clothing and electrical parts that can cause shocks or fires.**

**Running the engine while servicing can lead to eye injury, burns, fire, or carbon monoxide poisoning - possibly leading to death. See page 2-2 for more information about carbon monoxide.**

EAU17391

## Owner's tool kit

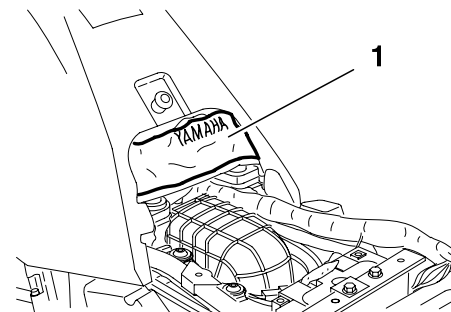

1. Owner's tool kit

The owner's tool kit is located under the seat. (See page 4-14).

The service information included in this manual and the tools provided in the owner's tool kit are intended to assist you in the performance of preventive maintenance and minor repairs. However, additional tools such as a torque wrench may be necessary to perform certain maintenance work correctly.

## TIP

If you do not have the tools or experience required for a particular job, have a Yamaha dealer perform it for you.

# PERIODIC MAINTENANCE AND ADJUSTMENT

EAU46861

## TIP

- The annual checks must be performed every year, except if a kilometer-based maintenance, or for the UK, a mileage-based maintenance, is performed instead.
- From 50000 km (30000 mi), repeat the maintenance intervals starting from 10000 km (6000 mi).
- Items marked with an asterisk should be performed by a Yamaha dealer as they require special tools, data and technical skills.

## Periodic maintenance chart for the emission control system

EAU46910

NO.	ITEM	CHECK OR MAINTENANCE JOB	ODOMETER READING					ANNUAL CHECK
			1000 km (600 mi)	10000 km (6000 mi)	20000 km (12000 mi)	30000 km (18000 mi)	40000 km (24000 mi)	
1	* Fuel line	<ul style="list-style-type: none"> <li>• Check fuel hoses for cracks or damage.</li> </ul>		√	√	√	√	√
2	Spark plug	<ul style="list-style-type: none"> <li>• Check condition.</li> <li>• Clean and regap.</li> </ul>		√		√		
		<ul style="list-style-type: none"> <li>• Replace.</li> </ul>			√		√	
3	* Valves	<ul style="list-style-type: none"> <li>• Check valve clearance.</li> <li>• Adjust.</li> </ul>			√		√	
4	* Fuel injection	<ul style="list-style-type: none"> <li>• Adjust engine idling speed.</li> </ul>	√	√	√	√	√	√
5	* Muffler and exhaust pipe	<ul style="list-style-type: none"> <li>• Check the screw clamp(s) for looseness.</li> </ul>	√	√	√	√	√	
6	* Air induction system	<ul style="list-style-type: none"> <li>• Check the air cut-off valve, reed valve, and hose for damage.</li> <li>• Replace any damaged parts if necessary.</li> </ul>		√	√	√	√	√

# PERIODIC MAINTENANCE AND ADJUSTMENT

EAU1770C

General maintenance and lubrication chart

NO.	ITEM	CHECK OR MAINTENANCE JOB	ODOMETER READING					ANNUAL CHECK
			1000 km (600 mi)	10000 km (6000 mi)	20000 km (12000 mi)	30000 km (18000 mi)	40000 km (24000 mi)	
1	<b>Air filter element</b>	<ul style="list-style-type: none"> <li>• Replace.</li> </ul>			√		√	
2	<b>Clutch</b>	<ul style="list-style-type: none"> <li>• Check operation.</li> <li>• Adjust.</li> </ul>	√	√	√	√	√	
3	* <b>Front brake</b>	<ul style="list-style-type: none"> <li>• Check operation, fluid level and vehicle for fluid leakage.</li> </ul>	√	√	√	√	√	√
		<ul style="list-style-type: none"> <li>• Replace brake pads.</li> </ul>	Whenever worn to the limit					
4	* <b>Rear brake</b>	<ul style="list-style-type: none"> <li>• Check operation, fluid level and vehicle for fluid leakage.</li> </ul>	√	√	√	√	√	√
		<ul style="list-style-type: none"> <li>• Replace brake pads.</li> </ul>	Whenever worn to the limit					
5	* <b>Brake hoses</b>	<ul style="list-style-type: none"> <li>• Check for cracks or damage.</li> </ul>		√	√	√	√	√
		<ul style="list-style-type: none"> <li>• Replace.</li> </ul>	Every 4 years					
6	* <b>Wheels</b>	<ul style="list-style-type: none"> <li>• Check runout, spoke tightness and for damage.</li> <li>• Tighten spokes if necessary.</li> </ul>		√	√	√	√	
7	* <b>Tires</b>	<ul style="list-style-type: none"> <li>• Check tread depth and for damage.</li> <li>• Replace if necessary.</li> <li>• Check air pressure.</li> <li>• Correct if necessary.</li> </ul>		√	√	√	√	√
8	* <b>Wheel bearings</b>	<ul style="list-style-type: none"> <li>• Check bearing for looseness or damage.</li> </ul>		√	√	√	√	

# PERIODIC MAINTENANCE AND ADJUSTMENT

NO.	ITEM	CHECK OR MAINTENANCE JOB	ODOMETER READING					ANNUAL CHECK	
			1000 km (600 mi)	10000 km (6000 mi)	20000 km (12000 mi)	30000 km (18000 mi)	40000 km (24000 mi)		
9	*	<b>Swingarm</b>	• Check operation and for excessive play.		√	√	√	√	
			• Lubricate with lithium-soap-based grease.	Every 50000 km (30000 mi)					
10		<b>Drive chain</b>	• Check chain slack, alignment and condition. • Adjust and lubricate chain with a special O-ring chain lubricant thoroughly.	Every 500 km (300 mi) and after washing the motorcycle or riding in the rain					
11	*	<b>Steering bearings</b>	• Check bearing play and steering for roughness.	√	√	√	√	√	
			• Lubricate with lithium-soap-based grease.	Every 50000 km (30000 mi)					
12	*	<b>Chassis fasteners</b>	• Make sure that all nuts, bolts and screws are properly tightened.		√	√	√	√	√
13		<b>Sidestand</b>	• Check operation. • Lubricate.		√	√	√	√	√
14	*	<b>Sidestand switch</b>	• Check operation.	√	√	√	√	√	√
15	*	<b>Front fork</b>	• Check operation and for oil leakage.		√	√	√	√	
16	*	<b>Shock absorber assembly</b>	• Check operation and shock absorber for oil leakage.		√	√	√	√	
17	*	<b>Rear suspension relay arm and connecting arm pivoting points</b>	• Check operation.		√	√	√	√	
			• Lubricate with lithium-soap-based grease.			√		√	
18		<b>Engine oil</b>	• Change. • Check oil level and vehicle for oil leakage.	√	√	√	√	√	√

# PERIODIC MAINTENANCE AND ADJUSTMENT

NO.	ITEM	CHECK OR MAINTENANCE JOB	ODOMETER READING					ANNUAL CHECK
			1000 km (600 mi)	10000 km (6000 mi)	20000 km (12000 mi)	30000 km (18000 mi)	40000 km (24000 mi)	
19	Engine oil filter element	• Replace.	√		√		√	
20	* Cooling system	• Check coolant level and vehicle for coolant leakage. • Change.		√	√	√	√	√
21	* Front and rear brake switches	• Check operation.	√	√	√	√	√	√
22	Moving parts and cables	• Lubricate.		√	√	√	√	√
23	* Throttle grip housing and cable	• Check operation and free play. • Adjust the throttle cable free play if necessary. • Lubricate the throttle grip housing and cable.		√	√	√	√	√
24	* Lights, signals and switches	• Check operation. • Adjust headlight beam.	√	√	√	√	√	√

EAUM1890

## TIP

- Replace the air filter element more frequently if you are riding in unusually wet or dusty areas.
- Hydraulic brake service
  - Regularly check and, if necessary, correct the brake fluid level.
  - Every two years replace the internal components of the brake master cylinder, and change the brake fluid.
  - Replace the brake hoses every four years and if cracked or damaged.

# PERIODIC MAINTENANCE AND ADJUSTMENT

## Removing and installing the cowling and panels

EAU18722

The cowling and panels shown need to be removed to perform some of the maintenance jobs described in this chapter. Refer to this section each time the cowling or a panel needs to be removed and installed.

### Panel A and B

EAUB1540

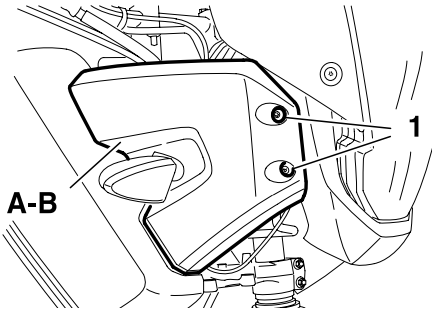

1. Panel mounting bolt
- A. Right panel
- B. Left panel

### To remove one of the panels

Remove the bolts, and then pull the panel off at the areas shown.

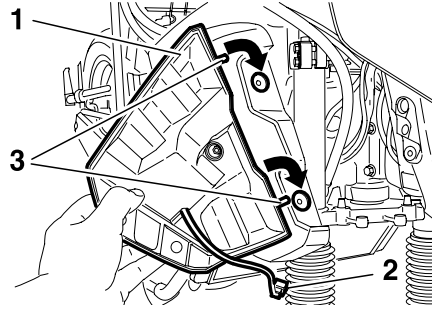

1. Panel
2. Turn signal light coupler
3. Pin

### To install the panel

Place the panel in the original position, and then install the bolts.

### Panel C and D

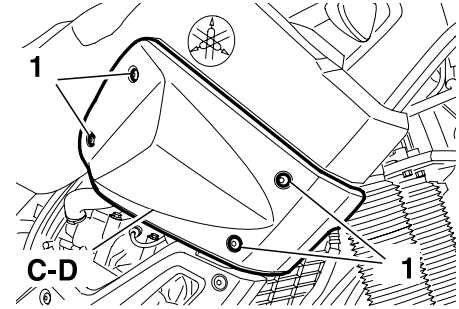

1. Panel mounting bolt
- C. Right panel
- D. Left panel

### To remove one of the panels

Remove the bolts, and then pull the panel off at the areas shown.

### To install the panel

Place the panel in the original position, and then install the bolts.



# PERIODIC MAINTENANCE AND ADJUSTMENT

## Panel E and F

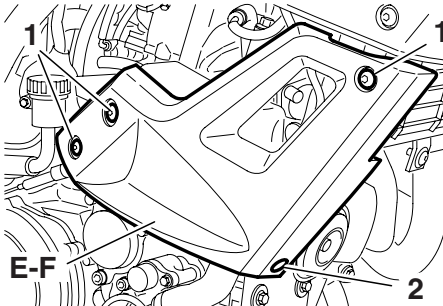

1. Panel mounting bolt
  2. Quick fastener
- E. Right panel  
F. Left panel

### To remove one of the panels

1. Remove the bolts.
2. Remove the quick fastener and then pull the panel off at the areas shown.

### To install the panel

1. Place the panel in the original position.
2. Install the quick fastener and the bolts.

## Panel G

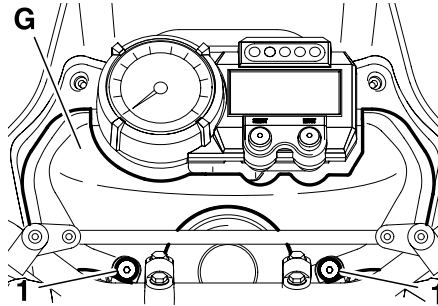

1. Panel mounting bolt
- G. Panel

### To remove the panel

Remove the bolts, and then pull the panel off at the areas shown.

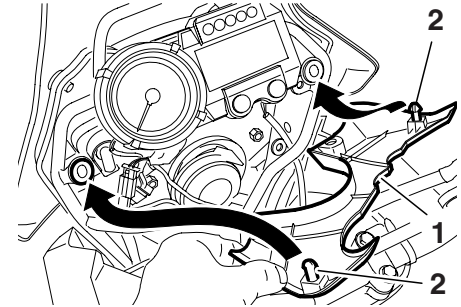

1. Panel
2. Pin

### To install the panel

Place the panel in the original position, and then install the bolts.

# PERIODIC MAINTENANCE AND ADJUSTMENT

EAU19603

## Checking the spark plug

The spark plug is an important engine component, which is easy to check. Since heat and deposits will cause any spark plug to slowly erode, the spark plug should be removed and checked in accordance with the periodic maintenance and lubrication chart. In addition, the condition of the spark plug can reveal the condition of the engine.

### To remove the spark plug

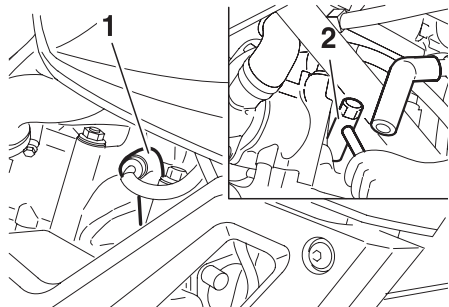

1. Spark plug cap
2. Spark plug wrench

1. Remove the spark plug cap.

2. Remove the spark plug as shown, with the spark plug wrench included in the owner's tool kit.

### To check the spark plug

1. Check that the porcelain insulator around the center electrode of the spark plug is a medium-to-light tan (the ideal color when the vehicle is ridden normally).

### TIP

If the spark plug shows a distinctly different color, the engine could be operating improperly. Do not attempt to diagnose such problems yourself. Instead, have a Yamaha dealer check the vehicle.

2. Check the spark plug for electrode erosion and excessive carbon or other deposits, and replace it if necessary.

**Specified spark plug:**  
CR7E (NGK)

### To install the spark plug

1. Measure the spark plug gap with a wire thickness gauge and, if necessary, adjust the gap to specification.

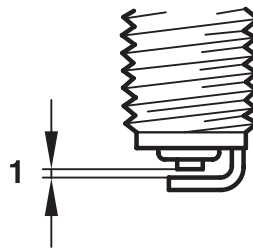

1. Spark plug gap

### Spark plug gap:

0.7-0.8 mm (0.028-0.032 in)

2. Clean the surface of the spark plug gasket and its mating surface, and then wipe off any grime from the spark plug threads.
3. Install the spark plug with the spark plug wrench, and then tighten it to the specified torque.

# PERIODIC MAINTENANCE AND ADJUSTMENT

## Tightening torque:

Spark plug:  
12.5 Nm (1.25 m·kgf, 9.0 ft·lbf)

## TIP

If a torque wrench is not available when installing a spark plug, a good estimate of the correct torque is 1/4-1/2 turn past finger tight. However, the spark plug should be tightened to the specified torque as soon as possible.

4. Install the spark plug cap.

EAUB1560

## Engine oil and oil filter element

The engine oil level should be checked before each ride. In addition, the oil must be changed and the oil filter element replaced at the intervals specified in the periodic maintenance and lubrication chart.

### To check the engine oil level

1. Place the vehicle on a level surface and hold it in an upright position.

## TIP

Make sure that the vehicle is positioned straight up when checking the oil level. A slight tilt to the side can result in a false reading.

2. Start the engine, warm it up for 10-15 minutes and then turn it off.
3. Remove the oil filler cap, wipe the dipstick clean, insert it back into the oil filler hole (without screwing it in), and then remove it again to check the oil level.

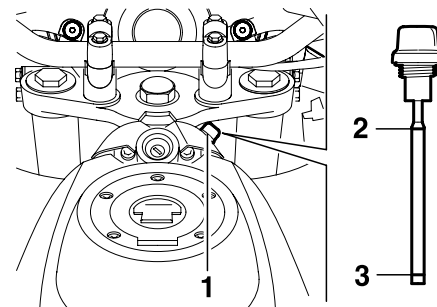

1. Engine oil filler cap
2. Maximum level mark
3. Minimum level mark

## TIP

- The engine oil tank is located inside of the frame.
- The engine oil should be between the minimum and maximum level marks.

# PERIODIC MAINTENANCE AND ADJUSTMENT

## NOTICE

ECA10010

Do not operate the vehicle until you know that the engine oil level is sufficient.

## WARNING

EWA10360

Never remove the engine oil tank cap after high-speed operation, otherwise hot engine oil could spout out and cause damage or injury. Always let the engine oil cool down sufficiently before removing the oil tank cap.

4. If the engine oil is below the minimum level mark, add sufficient oil of the recommended type to raise it to the correct level.
5. Install the oil filler cap.

To change the engine oil  
(with or without oil filter element replacement)

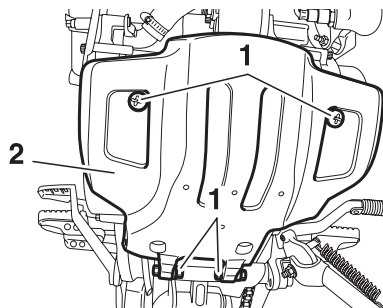

1. Mounting screw
2. Engine guard

1. Start the engine, warm it up for several minutes, and then turn it off.
2. To reach the drain bolt of the crankcase and the drain bolt of the oil tank, remove the engine guard by removing the screws.
3. Place an oil pan under the engine to collect the used oil.
4. Remove the engine oil filler cap and the drain bolt to drain the oil from the crankcase.
5. Remove the drain bolt to drain the oil from the oil tank.

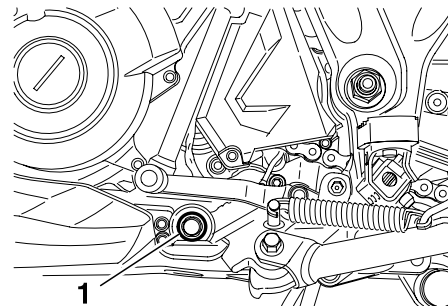

1. Engine oil crankcase drain bolt

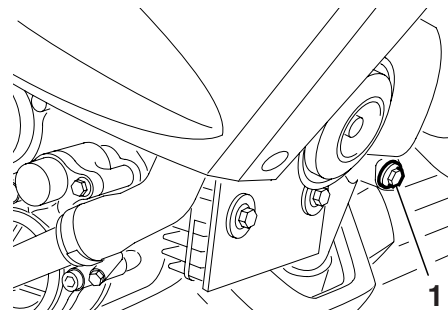

1. Engine oil tank drain bolt

6. Remove the oil filter element drain bolt to drain the oil from the oil filter element.

# PERIODIC MAINTENANCE AND ADJUSTMENT

**TIP** \_\_\_\_\_  
Skip steps 7-9 if the oil filter element is not being replaced.

7. Remove the oil filter element cover by removing the bolts.
8. Remove and replace the oil filter element and O-rings.
9. Install the oil filter element cover by installing the bolts.

**TIP** \_\_\_\_\_  
Make sure that the O-rings are properly seated.

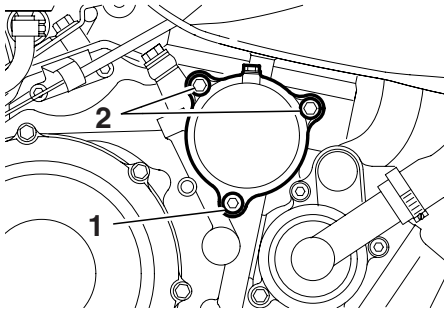

1. Engine oil filter element drain bolt
2. Oil filter element cover bolts

10. Install the oil filter element drain bolt.
11. Tighten the oil filter element cover bolts and the oil filter element drain bolt to their specified torques.

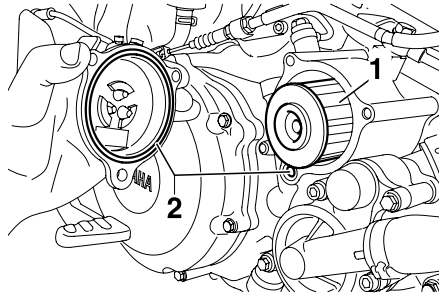

1. Engine oil filter element
2. O-rings

## Tightening torques:

- Oil filter element cover bolt:  
10 Nm (1.0 m-kgf, 7.2 ft-lbf)
- Oil filter element drain bolt:  
10 Nm (1.0 m-kgf, 7.2 ft-lbf)

12. Install the engine oil drain bolts, and then tighten them to their specified torques.

## Tightening torques:

- Engine oil drain bolt (crankcase):  
30 Nm (3.0 m-kgf, 22 ft-lbf)
- Engine oil drain bolt (oil tank):  
18 Nm (1.8 m-kgf, 12.9 ft-lbf)

13. Add the specified amount of the recommended engine oil, and then install and tighten the oil filter cap.

# PERIODIC MAINTENANCE AND ADJUSTMENT

## CAUTION:

ECAM1060

The engine oil tank must be filled in 2 steps. First, fill the engine oil tank with 1.90 L (2.0 US qt) (1.67 Imp.qt) of the recommended engine oil. Then, start the engine, race it 5 or 6 times, turn it off, and then add the remainder of the engine oil.

### Recommended engine oil:

See page 8-1.

### Oil quantity:

Without oil filter element replacement:

2.50 L (2.64 US qt) (2.19 Imp.qt)

With oil filter element replacement:

2.60 L (2.73 US qt) (2.26 Imp.qt)

## NOTE:

Be sure to wipe off spilled oil on any parts after the engine and exhaust system have cooled down.

## CAUTION:

ECA11620

- In order to prevent clutch slippage (since the engine oil also lubricates the clutch), do not mix any chemical additives. Do not use oils with a diesel specification of “CD” or oils of a higher quality than specified. In addition, do not use oils labeled “ENERGY CONSERVING II” or higher.
- Make sure that no foreign material enters the crankcase.

14. Start the engine, and then let it idle for several minutes while checking it for oil leakage. If oil is leaking, immediately turn the engine off and check for the cause.
15. Turn the engine off, and then check the oil level and correct it if necessary.
16. Install the engine guard by installing the screws.

EAU20070

## Coolant

The coolant level should be checked before each ride. In addition, the coolant must be changed at the intervals specified in the periodic maintenance and lubrication chart.

EAU20253

### To check the coolant level

1. Place the vehicle on a level surface and hold it in an upright position.

## NOTE:

- The coolant level must be checked on a cold engine since the level varies with engine temperature.
  - Make sure that the vehicle is positioned straight up when checking the coolant level. A slight tilt to the side can result in a false reading.
2. Check the coolant level in the coolant reservoir.

## TIP \_\_\_\_\_

The coolant should be between the minimum and maximum level marks.

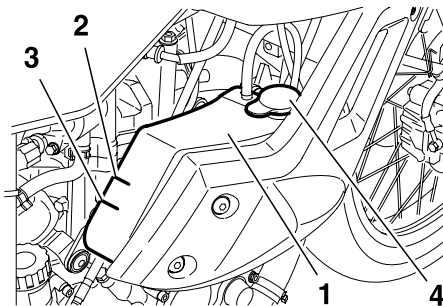

1. Coolant reservoir
2. Maximum level mark
3. Minimum level mark
4. Reservoir cap

3. If the coolant is at or below the minimum level mark, remove panel E (See page 7-7.), remove the reservoir cap, add coolant to the maximum level mark, and then install the reservoir cap and the panel. **WARNING! Remove only the coolant reservoir cap. Never attempt to remove the radiator cap when the engine is hot. NOTICE: If coolant is not available, use distilled water or soft**

tap water instead. Do not use hard water or salt water since it is harmful to the engine. If water has been used instead of coolant, replace it with coolant as soon as possible, otherwise the cooling system will not be protected against frost and corrosion. If water has been added to the coolant, have a Yamaha dealer check the antifreeze content of the coolant as soon as possible, otherwise the effectiveness of the coolant will be reduced.

**Coolant reservoir capacity  
(up to the maximum level mark):**  
0.50 L (0.52 US qt) (0.44 Imp.

## Changing the coolant

The coolant must be changed at the intervals specified in the periodic maintenance and lubrication chart. Have a Yamaha dealer change the coolant. **WARNING! Never attempt to remove the radiator cap when the engine is hot.**

# PERIODIC MAINTENANCE AND ADJUSTMENT

EAUB1480

## Replacing the air filter element and cleaning the check hose

The air filter element should be replaced at the intervals specified in the periodic maintenance and lubrication chart. Replace the air filter element more frequently if you are riding in unusually wet or dusty areas. In addition, the air filter check hose must be frequently checked and cleaned if necessary.

### To replace the air filter element

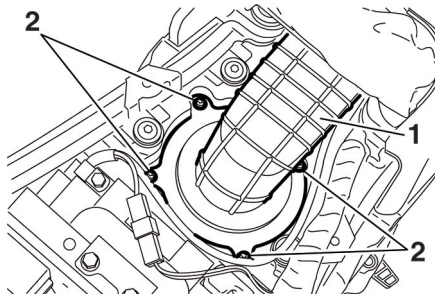

1. Air filter case
2. Screws

1. Remove the seat. (See page 4-14.)
2. Remove the air filter case cover by removing the screws.
3. Pull the air filter element out.
4. Insert a new air filter element into the air filter case as shown.

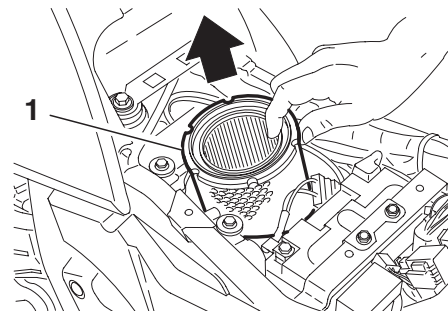

1. Air filter element

ECA10480

### NOTICE

- **Make sure that the air filter element is properly seated in the air filter case.**
- **The engine should never be operated without the air filter element installed, otherwise the piston(s) and/or cylinder(s) may become excessively worn.**

5. Install the air filter case cover by installing the screws.
6. Install the seat.



# PERIODIC MAINTENANCE AND ADJUSTMENT

## To clean the air filter check hose

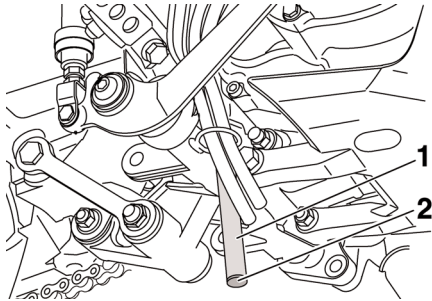

1. Air filter check hose
2. Check hose cap

1. Check the hose on the side of the air filter case for accumulated dirt or water.
2. If dirt or water is visible, remove the hose, clean it, and then install it.

EAU44734

## Checking the engine idling speed

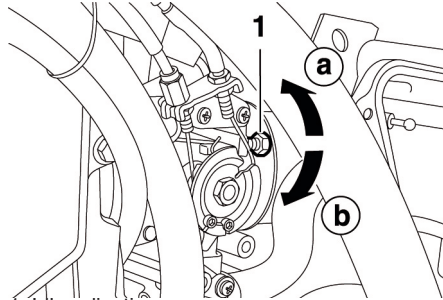

1. Idle adjusting screw
- a. Increasing the engine idling speed
- b. Decreasing the engine idling speed

**Engine idling speed:**  
1400–1600 r/min

The engine idling speed must be checked as follows and, if necessary, adjusted by a Yamaha dealer at the intervals specified in the periodic maintenance and lubrication chart.

Start the engine and warm it up for several minutes at 1000-2000 r/min while occasionally revving it to 4000-5000 r/min.

# PERIODIC MAINTENANCE AND ADJUSTMENT

---

EAU21382

## Checking the throttle cable free play

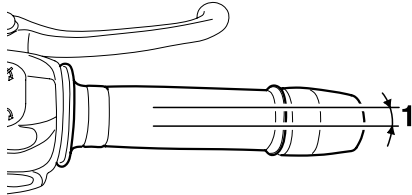

### 1. Throttle cable free play

The throttle cable free play should measure 3.0-5.0 mm (0.12-0.20 in) at the throttle grip. Periodically check the throttle cable free play and, if necessary, have a Yamaha dealer adjust it.

7

## Valve clearance

The valve clearance changes with use, resulting in improper air-fuel mixture and/or engine noise. To prevent this from occurring, the valve clearance must be adjusted by a Yamaha dealer at the intervals specified in the periodic maintenance and lubrication chart.

EAU21401

## Tires

To maximize the performance, durability, and safe operation of your motorcycle, note the following points regarding the specified tires.

### Tire air pressure

The tire air pressure should be checked and, if necessary, adjusted before each ride.

EWA10501

### **⚠ WARNING**

**Operation of this vehicle with improper tire pressure may cause severe injury or death from loss of control.**

- The tire air pressure must be checked and adjusted on cold tires (i.e., when the temperature of the tires equals the ambient temperature).
- The tire air pressure must be adjusted in accordance with the riding speed and with the total weight of rider, passenger, cargo, and accessories approved for this model.

# PERIODIC MAINTENANCE AND ADJUSTMENT

EWA10511

## **WARNING**

Never overload your vehicle. Operation of an overloaded vehicle could cause an accident.

EWA10461

## **WARNING**

The front and rear tires should be of the same make and design, otherwise the handling characteristics of the vehicle may be different, which could lead to an accident.

### **Tire air pressure**

(measured on cold tires):

#### **Up to 90 kg (198 lb):**

Front:

210 kPa (30 psi) (2.1 kgf/cm<sup>2</sup>)

Rear:

230 kPa (33 psi) (2.3 kgf/cm<sup>2</sup>)

#### **90 kg (198 lb) to maximum load:**

Front:

230 kPa (33 psi) (2.3 kgf/cm<sup>2</sup>)

Rear:

250 kPa (36 psi) (2.5 kgf/cm<sup>2</sup>)

#### **Off-road riding:**

Front:

200 kPa (29 psi) (2.0 kgf/cm<sup>2</sup>)

Rear:

200 kPa (29 psi) (2.0 kgf/cm<sup>2</sup>)

#### **High-speed riding:**

Front:

210 kPa (30 psi) (2.1 kgf/cm<sup>2</sup>)

Rear:

230 kPa (33 psi) (2.3 kgf/cm<sup>2</sup>)

#### **Maximum load\*:**

190 kg (419 lb)

\* Total weight of rider, passenger, cargo and accessories

# PERIODIC MAINTENANCE AND ADJUSTMENT

## Tire inspection

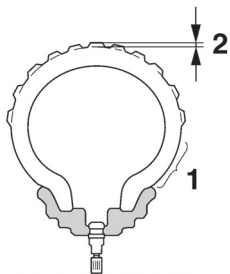

1. Tire sidewall
2. Tire tread depth

The tires must be checked before each ride. If the center tread depth reaches the specified limit, if the tire has a nail or glass fragments in it, or if the sidewall is cracked, have a Yamaha dealer replace the tire immediately.

### Minimum tire tread depth (front and rear):

1.0 mm (0.04 in)

## TIP \_\_\_\_\_

The tire tread depth limits may differ from country to country. Always comply with the local regulations.

## Tire information

This motorcycle is equipped with tube tires.

### Front tire:

Size:

90/90-21M/C 54S

90/90-21M/C 54T

Manufacturer/model:

METZELER/TOURANCE

FRONT

MICHELIN/SIRAC

### Rear tire:

Size:

130/80-17M/C 65S

130/80-17M/C 65T

Manufacturer/model:

METZELER/TOURANCE

MICHELIN/SIRAC A

# PERIODIC MAINTENANCE AND ADJUSTMENT

---

EAU21940

## Spoke wheels

To maximize the performance, durability, and safe operation of your motorcycle, note the following points regarding the specified wheels.

- The wheel rims should be checked for cracks, bends or warpage, and the spokes for looseness or damage before each ride. If any damage is found, have a Yamaha dealer replace the wheel. Do not attempt even the smallest repair to the wheel. A deformed or cracked wheel must be replaced.
- The wheel should be balanced whenever either the tire or wheel has been changed or replaced. An unbalanced wheel can result in poor performance, adverse handling characteristics, and a shortened tire life.
- Ride at moderate speeds after changing a tire since the tire surface must first be "broken in" for it to develop its optimal characteristics.

# PERIODIC MAINTENANCE AND ADJUSTMENT

EAU22043

## Adjusting the clutch lever free play

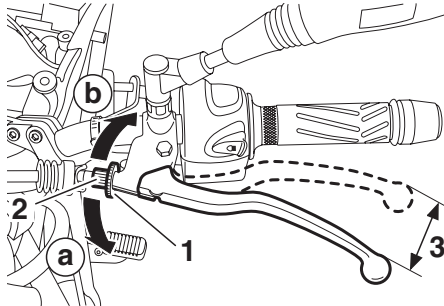

1. Locknut
2. Adjusting bolt
3. Clutch lever free play

**7** The clutch lever free play should measure 10.0-15.0 mm (0.39-0.59 in) as shown. Periodically check the clutch lever free play and, if necessary, adjust it as follows.

1. Slide the rubber cover back at the clutch lever.
2. Loosen the locknut.

3. To increase the clutch lever free play, turn the adjusting bolt in direction (a). To decrease the clutch lever free play, turn the adjusting bolt in direction (b).

### TIP

If the specified clutch lever free play could be obtained as described above, skip steps 4-7.

4. Fully turn the adjusting bolt at the clutch lever in direction (a) to loosen the clutch cable.
5. Loosen the locknut at the crankcase.

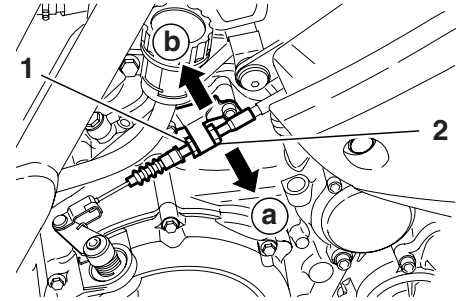

1. Locknut
2. Clutch lever free play adjusting nut (crankcase)

6. To increase the clutch lever free play, turn the adjusting nut in direction (a). To decrease the clutch lever free play, turn the adjusting nut in direction (b).
7. Tighten the locknut at the crankcase.
8. Tighten the locknut at the clutch lever and then slide the rubber cover to its original position.

# PERIODIC MAINTENANCE AND ADJUSTMENT

EAU22390

## Checking the front and rear brake pads

The front and rear brake pads must be checked for wear at the intervals specified in the periodic maintenance and lubrication chart.

### Front brake pads

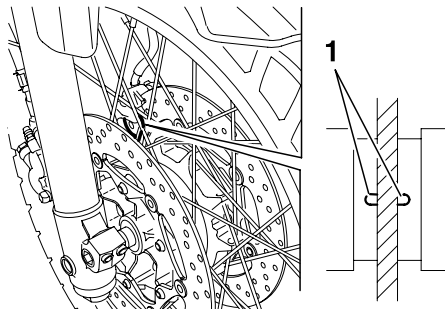

1. Front brake pad wear indicator groove

Each front brake pad is provided with a wear indicator groove, which allows you to check the brake pad wear without having to disassemble the brake. To check the brake pad wear, check the wear indicator groove. If a brake pad has worn to the point that the wear indicator groove has almost disappeared, have a Yamaha dealer replace the brake pads as a set.

EAU22420

### Rear brake pads

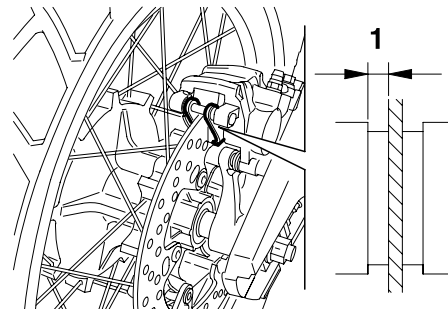

1. Rear brake pad lining thickness

Check each rear brake pad for damage and measure the lining thickness. If a brake pad is damaged or if the lining thickness is less than 1.0 mm (0.04 in), have a Yamaha dealer replace the brake pads as a set.

# PERIODIC MAINTENANCE AND ADJUSTMENT

EAU22580

## Checking the brake fluid level

### Front brake

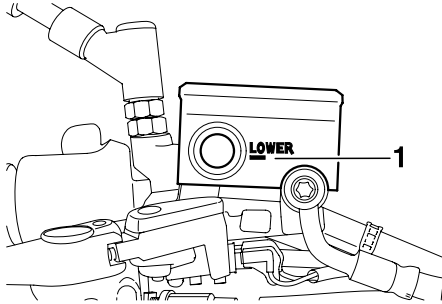

1. Minimum level mark

### Rear brake

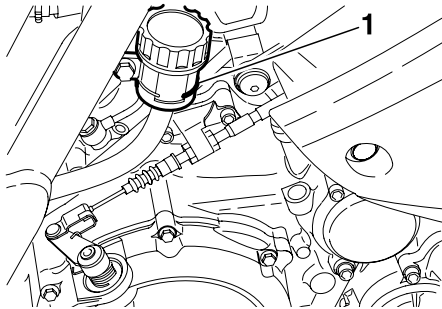

1. Minimum level mark

Insufficient brake fluid may allow air to enter the brake system, possibly causing it to become ineffective.

Before riding, check that the brake fluid is above the minimum level mark and replenish if necessary.

A low brake fluid level may indicate worn brake pads and/or brake system leakage. If the brake fluid level is low, be sure to check the brake pads for wear and the brake system for leakage.

Observe these precautions:

- When checking the fluid level, make sure that the top of the brake fluid reservoir is level.
- Use only the recommended quality brake fluid, otherwise the rubber seals may deteriorate, causing leakage and poor braking performance.

- Refill with the same type of brake fluid. Mixing fluids may result in a harmful chemical reaction and lead to poor braking performance.
- Be careful that water does not enter the brake fluid reservoir when refilling. Water will significantly lower the boiling point of the fluid and may result in vapor lock.
- Brake fluid may deteriorate painted surfaces or plastic parts. Always clean up spilled fluid immediately.
- As the brake pads wear, it is normal for the brake fluid level to gradually go down. However, if the brake fluid level goes down suddenly, have a Yamaha dealer check the cause.

**Recommended brake fluid:**  
DOT 4



# PERIODIC MAINTENANCE AND ADJUSTMENT

EAU22731

## Changing the brake fluid

Have a Yamaha dealer change the brake fluid at the intervals specified in the TIP after the periodic maintenance and lubrication chart. In addition, have the oil seals of the master cylinders and calipers as well as the brake hoses replaced at the intervals listed below or whenever they are damaged or leaking.

- Oil seals: Replace every two years.
- Brake hoses: Replace every four years.

EAU22760

## Drive chain slack

The drive chain slack should be checked before each ride and adjusted if necessary.

EAU22783

### To check the drive chain slack

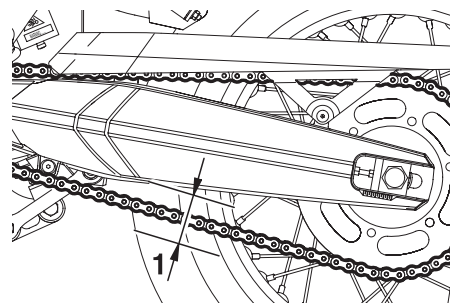

1. Drive chain slack

1. Place the motorcycle on the side-stand.

### TIP

When checking and adjusting the drive chain slack, there should be no weight on the motorcycle.

2. Shift the transmission into the neutral position.
3. Move the rear wheel by pushing the motorcycle to locate the tightest portion of the drive chain, and then measure the drive chain slack as shown.

**Drive chain slack:**  
50.0-60.0 mm (1.96-2.36 in)

4. If the drive chain slack is incorrect, adjust it as follows.

### TIP

When checking the drive chain slack, the chain tensioner should not be touching the drive chain.

# PERIODIC MAINTENANCE AND ADJUSTMENT

EAU34314

## To adjust the drive chain slack

1. Loosen the axle nut and the locknut on each side of the swingarm.
2. To tighten the drive chain, turn the drive chain slack adjusting bolt on each side of the swingarm in direction (a). To loosen the drive chain, turn the adjusting bolt on each side of the swingarm in direction (b), and then push the rear wheel forward. **NOTICE: Improper drive chain slack will overload the engine as well as other vital parts of the motorcycle and can lead to chain slippage or breakage. To prevent this from occurring, keep the drive chain slack within the specified limits.**

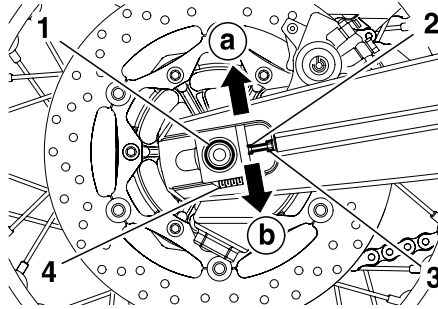

1. Wheel axle
2. Drive chain slack adjusting bolt
3. Locknut
4. Alignment marks

## TIP

Using the alignment marks on each side of the swingarm, make sure that both chain pullers are in the same position for proper wheel alignment.

3. Tighten the axle nut, then the locknuts to their specified torques.

## Tightening torques:

Axle nut:

105 Nm (10.5 m·kgf, 75 ft·lbf)

Locknut:

16 Nm (1.6 m·kgf, 11 ft·lbf)

EAU23023

## Cleaning and lubricating the drive chain

The drive chain must be cleaned and lubricated at the intervals specified in the periodic maintenance and lubrication chart, otherwise it will quickly wear out, especially when riding in dusty or wet areas. Service the drive chain as follows.

ECA10581

### **NOTICE**

**The drive chain must be lubricated after washing the motorcycle and riding in the rain.**

1. Clean the drive chain with kerosene and a small soft brush. **NOTICE: To prevent damaging the O-rings, do not clean the drive chain with steam cleaners, high-pressure washers or inappropriate solvents.**

2. Wipe the drive chain dry.
3. Thoroughly lubricate the drive chain with a special O-ring chain lubricant. **NOTICE: Do not use engine oil or any other lubricants for the drive chain, as they may contain substances that could damage the O-rings.**

EAU23101

## Checking and lubricating the cables

The operation of all control cables and the condition of the cables should be checked before each ride, and the cables and cable ends should be lubricated if necessary. If a cable is damaged or does not move smoothly, have a Yamaha dealer check or replace it. **WARNING! Damage to the outer sheath may interfere with proper cable operation and will cause the inner cable to rust. Replace a damaged cable as soon as possible to prevent unsafe conditions.**

**Recommended lubricant:**  
Engine oil

# PERIODIC MAINTENANCE AND ADJUSTMENT

EAU23111

## Checking and lubricating the throttle grip and cable

The operation of the throttle grip should be checked before each ride. In addition, the cable should be lubricated at the intervals specified in the periodic maintenance chart.

EAU23142

## Checking and lubricating the brake and clutch levers

### Brake lever

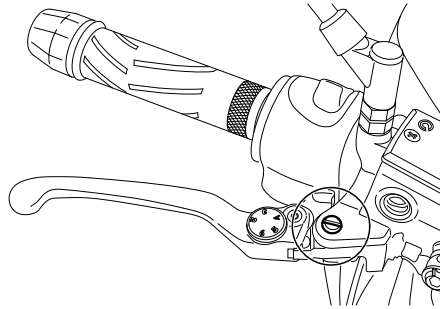

### Clutch lever

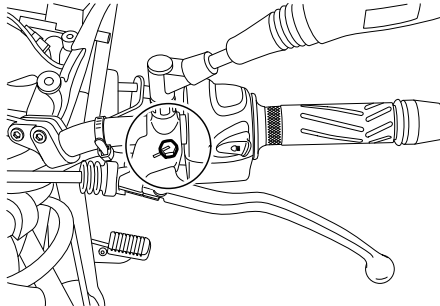

The operation of the brake and clutch levers should be checked before each ride, and the lever pivots should be lubricated if necessary.

### Recommended lubricants:

Brake lever:

Silicone grease

Clutch lever:

Lithium-soap-based grease

# PERIODIC MAINTENANCE AND ADJUSTMENT

EAU23182

## Checking and lubricating the brake pedal

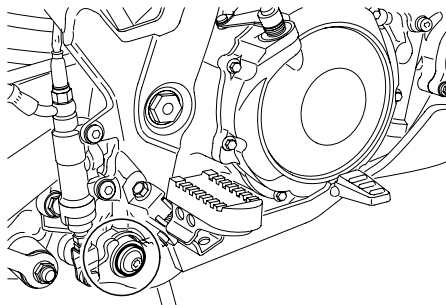

The operation of the brake pedal should be checked before each ride, and the pedal pivot should be lubricated if necessary.

**Recommended lubricant:**  
Lithium-soap-based grease

EAU23202

## Checking and lubricating the sidestand

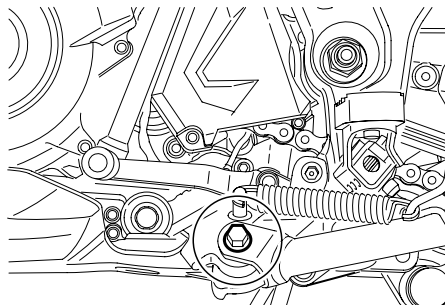

The operation of the sidestand should be checked before each ride, and the sidestand pivot and metal-to-metal contact surfaces should be lubricated if necessary.

### **⚠ WARNING**

**If the sidestand does not move up and down smoothly, have a Yamaha dealer check or repair it. Otherwise, the sidestand could contact the ground and distract the operator, resulting in a possible loss of control.**

**Recommended lubricant:**  
Lithium-soap-based grease

EAU23250

## Lubricating the rear suspension

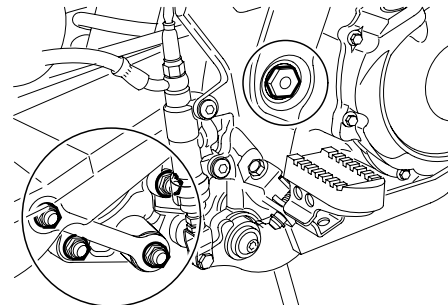

The pivoting points of the rear suspension must be lubricated at the intervals specified in the periodic maintenance and lubrication chart.

**Recommended lubricant:**  
Lithium-soap-based grease

# PERIODIC MAINTENANCE AND ADJUSTMENT

EAJM1650

## Lubricating the swingarm pivots

The swingarm pivots must be lubricated at the intervals specified in the periodic maintenance and lubrication chart.

**Recommended lubricant:**  
Lithium-soap-based grease

EAU23272

## Checking the front fork

The condition and operation of the front fork must be checked as follows at the intervals specified in the periodic maintenance and lubrication chart.

### To check the condition

Check the inner tubes for scratches, damage and excessive oil leakage.

### To check the operation

1. Place the motorcycle on a level surface and hold it in an upright position. **WARNING! To avoid injury, securely support the vehicle so there is no danger of it falling over.**
2. While applying the front brake, push down hard on the handlebars several times to check if the front fork compresses and rebounds smoothly.

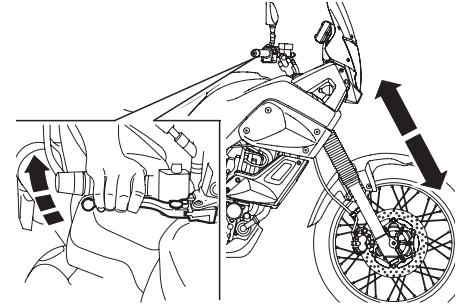

ECA10590

### **NOTICE**

**If any damage is found or the front fork does not operate smoothly, have a Yamaha dealer check or repair it.**

EAU23283

## Checking the steering

Worn or loose steering bearings may cause danger. Therefore, the operation of the steering must be checked as follows at the intervals specified in the periodic maintenance and lubrication chart.

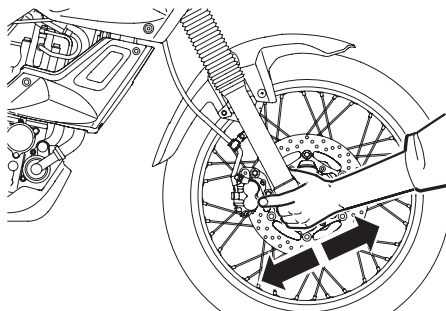

1. Place a stand under the engine to raise the front wheel off the ground. (See page 7-36 for more information.) **WARNING! To avoid injury, securely support the vehicle so there is no danger of it falling over.**

2. Hold the lower ends of the front fork legs and try to move them forward and backward. If any free play can be felt, have a Yamaha dealer check or repair the steering.

EAU23290

## Checking the wheel bearings

The front and rear wheel bearings must be checked at the intervals specified in the periodic maintenance and lubrication chart. If there is play in the wheel hub or if the wheel does not turn smoothly, have a Yamaha dealer check the wheel bearings.

# PERIODIC MAINTENANCE AND ADJUSTMENT

EAUB1432

## Battery

This model is equipped with a VRLA (Valve Regulated Lead Acid) battery. There is no need to check the electrolyte or to add distilled water. However, the battery lead connections need to be checked and, if necessary, tightened.

ECA10620

### NOTICE

**Never attempt to remove the battery cell seals, as this would permanently damage the battery.**

EWA10760

### WARNING

- **Electrolyte is poisonous and dangerous since it contains sulfuric acid, which causes severe burns. Avoid any contact with skin, eyes or clothing and always shield your eyes when working near batteries. In case of contact, administer the following FIRST AID.**
  - **EXTERNAL:** Flush with plenty of water.
  - **INTERNAL:** Drink large quantities of water or milk and immediately call a physician.
  - **EYES:** Flush with water for 15 minutes and seek prompt medical attention.
- **Batteries produce explosive hydrogen gas. Therefore, keep sparks, flames, cigarettes, etc., away from the battery and provide sufficient ventilation when charging it in an enclosed space.**
- **KEEP THIS AND ALL BATTERIES OUT OF THE REACH OF CHILDREN.**

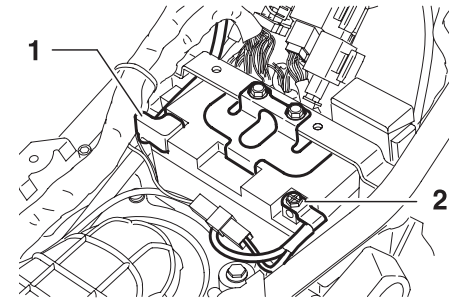

1. Positive battery terminal
2. Negative battery terminal

### To access the battery

Remove the battery holder bracket by removing the bolts.

### To charge the battery

Have a Yamaha dealer charge the battery as soon as possible if it seems to have discharged. Keep in mind that the battery tends to discharge more quickly if the vehicle is equipped with optional electrical accessories.



# PERIODIC MAINTENANCE AND ADJUSTMENT

## NOTICE

ECA16520

To charge a VRLA (Valve Regulated Lead Acid) battery, a special (constant-voltage) battery charger is required. Using a conventional battery charger will damage the battery. If you do not have access to a constant-voltage battery charger, have a Yamaha dealer charge your battery.

## To store the battery

1. If the vehicle will not be used for more than one month, remove the battery, fully charge it, and then place it in a cool, dry place. **NOTICE: When removing the battery, be sure the key is turned to "OFF", then disconnect the negative lead before disconnecting the positive lead.**
2. If the battery will be stored for more than two months, check it at least once a month and fully charge it if necessary.
3. Fully charge the battery before installation.

4. After installation, make sure that the battery leads are properly connected to the battery terminals.

## NOTICE

ECA16530

Always keep the battery charged. Storing a discharged battery can cause permanent battery damage.

## Replacing the fuses

EAUB1490

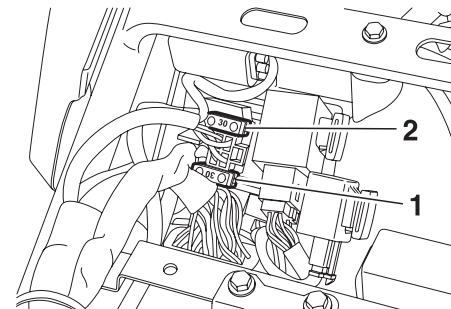

1. Main fuse
2. Reserve fuse

# PERIODIC MAINTENANCE AND ADJUSTMENT

ECA10640

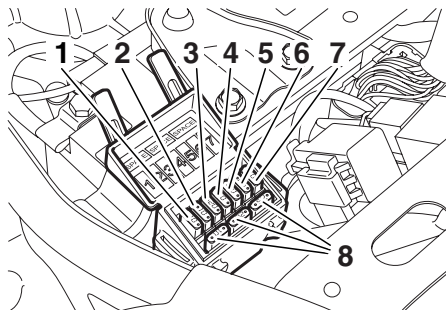

1. Parking lighting fuse
2. Signaling system fuse
3. Headlight fuse
4. Ignition fuse
5. Electronic fuel injection fuse
6. Radiator fan fuse
7. Backup fuse
8. Reserve fuses

## Specified fuses:

- Main fuse:  
30 A
- Parking lighting fuse:  
10 A
- Signalling system fuse:  
10 A
- Headlight fuse:  
20 A
- Ignition fuse:  
10 A
- Fuel injection system fuse:  
10 A
- Radiator fan fuse:  
7.5 A
- Backup fuse (for odometer,  
clock and immobilizer):  
10 A

## NOTICE

**Do not use a fuse of a higher amperage rating than recommended to avoid causing extensive damage to the electrical system and possibly a fire.**

3. Turn the key to "ON" and turn on the electrical circuit in question to check if the device operates.
4. If the fuse immediately blows again, have a Yamaha dealer check the electrical system.

7

The main fuse and fuse box are located under the seat. (See page 7-31.)

If a fuse is blown, replace it as follows.

1. Turn the key to "OFF" and turn off the electrical circuit in question.
2. Remove the blown fuse, and then install a new fuse of the specified amperage.

# PERIODIC MAINTENANCE AND ADJUSTMENT

EAUB1580

## Replacing a headlight bulb

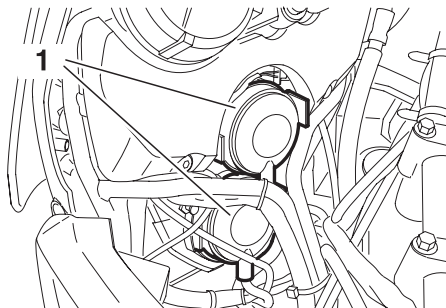

1. Headlight bulb cover

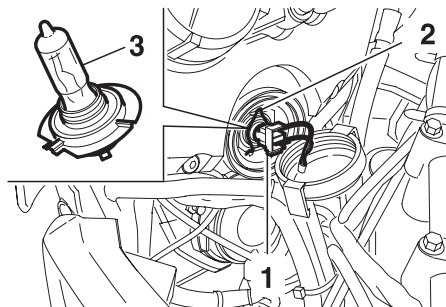

1. Headlight coupler  
2. Headlight bulb holder  
3. Headlight bulb

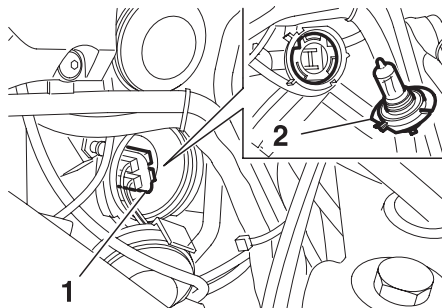

1. Headlight bulb holder  
2. Headlight bulb

This model is equipped with quartz bulb headlights. If a headlight bulb burns out, replace it as follows.

1. Remove the headlight bulb cover, and then disconnect the headlight coupler.
2. Unhook the headlight bulb holder, and then remove the defective bulb.

### **WARNING**

Headlight bulbs get very hot. Therefore, keep flammable products away from a lit headlight bulb, and do not touch the bulb until it has cooled down.

3. Place a new headlight bulb into position, and then secure it with the bulb holder.

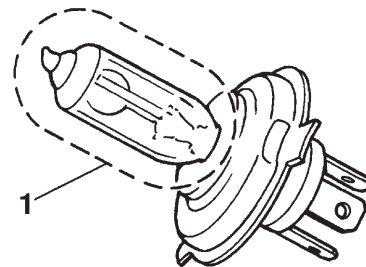

1. Do not touch this area

# PERIODIC MAINTENANCE AND ADJUSTMENT

ECA10650

## NOTICE

Take care not to damage the following parts:

- **Headlight bulb**
  - Do not touch the glass part of the headlight bulb to keep it free from oil, otherwise the transparency of the glass, the luminosity of the bulb, and the bulb life will be adversely affected. Thoroughly clean off any dirt and fingerprints on the headlight bulb using a cloth moistened with alcohol or thinner.
- **Headlight lens**
  - Do not affix any type of tinted film or stickers to the headlight lens.
  - Do not use a headlight bulb of a wattage higher than specified.

4. Connect the coupler, and then install the headlight bulb cover.
5. Have a Yamaha dealer adjust the headlight beam if necessary.

EAU24204

## Replacing a turn signal light bulb

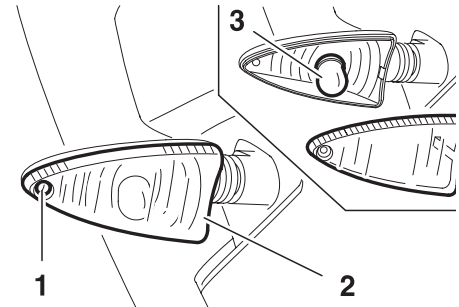

1. Screw
2. Turn signal light lens
3. Turn signal light bulb

1. Remove the turn signal light lens by removing the screw.
2. Remove the burnt-out bulb by pushing it in and turning it counterclockwise.
3. Insert a new bulb into the socket, push it in, and then turn it clockwise until it stops.

# PERIODIC MAINTENANCE AND ADJUSTMENT

4. Install the lens by installing the screw. **NOTICE:** Do not over-tighten the screw, otherwise the lens may break.

EAUM2202

EAU42652

## Replacing the license plate light bulb

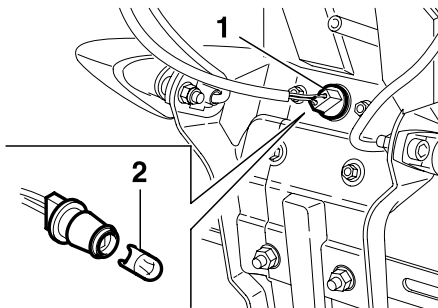

1. Bulb socket
2. License plate light bulb

1. Remove the socket (together with the bulb) by pulling it out.
2. Remove the burnt-out bulb by pulling it out.
3. Insert a new bulb into the socket.
4. Install the socket (together with the bulb) by pushing it in.

## Replacing an auxiliary light bulb

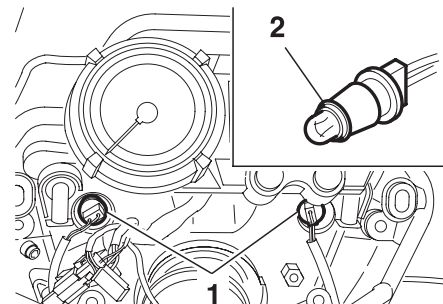

1. Auxiliary light socket
2. Auxiliary light bulb

This model is equipped with two auxiliary lights. If an auxiliary light bulb burns out, replace it as follows.

1. Remove panel G. (See page 7-7.)
2. Remove the auxiliary light socket (together with the bulb) by pulling it out.
3. Remove the burnt-out bulb by pulling it out.
4. Insert a new bulb into the socket.
5. Install the auxiliary light socket (together with the bulb) by pushing it in.
6. Install the panel.

# PERIODIC MAINTENANCE AND ADJUSTMENT

EAU24350

## Supporting the motorcycle

Since this model is not equipped with a centerstand, follow these precautions when removing the front and rear wheel or performing other maintenance requiring the motorcycle to stand upright. Check that the motorcycle is in a stable and level position before starting any maintenance. A strong wooden box can be placed under the engine for added stability.

## To service the front wheel

1. Stabilize the rear of the motorcycle by using a motorcycle stand or, if an additional motorcycle stand is not available, by placing a jack under the frame in front of the rear wheel.
2. Raise the front wheel off the ground by using a motorcycle stand.

## To service the rear wheel

Raise the rear wheel off the ground by using a motorcycle stand or, if a motorcycle stand is not available, by placing a jack either under each side of the frame in front of the rear wheel or under each side of the swingarm.

EAU24360

## Front wheel

EAUB1440

## To remove the front wheel

EWA10820

### **! WARNING**

- It is advisable to have a Yamaha dealer service the wheel.
- Securely support the motorcycle so that there is no danger of it falling over.

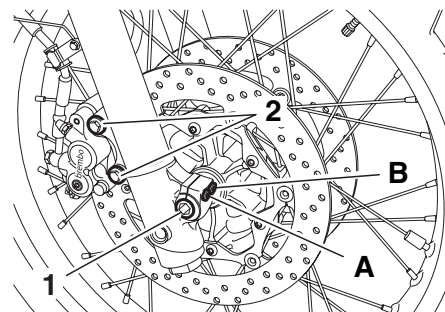

1. Wheel axle
2. Brake caliper bolts
- A. Front wheel axle pinch bolt
- B. Front wheel axle pinch bolt

# PERIODIC MAINTENANCE AND ADJUSTMENT

1. Loosen the front wheel axle pinch bolts, the wheel axle and the brake caliper bolts.
2. Lift the front wheel off the ground according to the procedure on page 7-36.
3. Remove the brake caliper on each side by removing the bolts.

Eaub1470

## To install the front wheel

1. Lift the wheel up between the fork legs.
2. Insert the wheel axle.
3. Install the brake calipers by installing the bolts.

## TIP

Make sure that there is enough space between the brake pads before installing the brake calipers onto the brake discs.

## NOTICE

ECA11050

**Do not apply the brake after the brake calipers have been removed, otherwise the brake pads will be forced shut.**

4. Pull the wheel axle out, and then remove the wheel.

4. Lower the front wheel so that it is on the ground.
5. Tighten the wheel axle and the brake caliper bolts to the specified torques.

ECAB0060

## NOTICE

**Be sure the right brake disc is positioned exactly in the middle of the caliper pads to prevent any brake drag. Tap the side of the right fork leg to position the disc correctly.**

6. Tighten wheel axle pinch bolt A, and then pinch bolt B to the specified torque.
7. Retighten pinch bolt A to the specified torque.

## Tightening torques:

Wheel axle:

60 Nm (6.0 m·kgf, 44 ft·lbf)

Front wheel axle pinch bolt:

18 Nm (1.8 m·kgf, 13 ft·lbf)

Brake caliper bolt:

40 Nm (4.0 m·kgf, 29 ft·lbf)

8. Apply the front brake several times, and then while holding the brake lever in, push down hard on the handlebar several times to check for proper fork operation.

# PERIODIC MAINTENANCE AND ADJUSTMENT

## Rear wheel

EAU25080

### To remove the rear wheel

EAU25312

EWA10821

#### **⚠ WARNING**

To avoid injury, securely support the vehicle so there is no danger of it falling over.

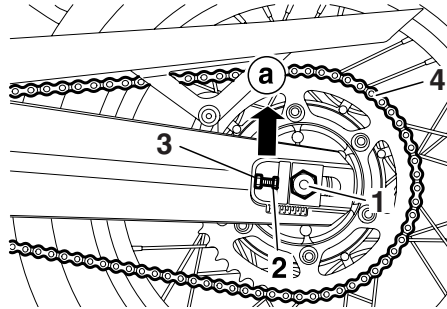

1. Wheel axle nut
2. Drive chain slack adjusting bolt
3. Locknut
4. Drive chain

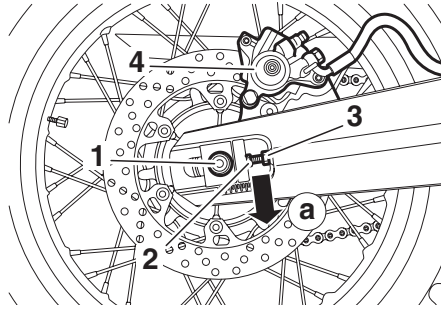

1. Wheel axle
2. Drive chain slack adjusting bolt
3. Locknut
4. Brake caliper

1. Loosen the axle nut.
2. Lift the rear wheel off the ground according to the procedure on page 7-36.
3. Remove the axle nut.
4. Loosen the locknut on each side of the swingarm.
5. Turn the drive chain slack adjusting bolts fully in direction (a) and push the wheel forward.
6. Remove the drive chain from the rear sprocket.

#### TIP

- If the drive chain is difficult to remove, remove the wheel axle first, and then lift the wheel upward enough to remove the drive chain from the rear sprocket.
- The drive chain cannot be disassembled.

7. While supporting the brake caliper bracket, pull the wheel axle out, and then remove the wheel. **NOTICE: Do not apply the brake after the wheel has been removed together with the brake disc, otherwise the brake pads will be forced shut.**

EAUB1450

#### To install the rear wheel

1. Install the wheel and the brake caliper bracket by inserting the wheel axle from the right-hand side.



## TIP

- Make sure that the slot in the brake caliper bracket is fit over the retainer on the swingarm.
  - Make sure that there is enough space between the brake pads before installing the wheel.
2. Install the drive chain onto the rear sprocket.
  3. Install the axle nut, and then lower the rear wheel so that it is on the ground.
  4. Adjust the drive chain slack. (See page 7-24.)
  5. Apply the rear brake several times, and then tighten the axle nut to the specified torque.

### Tightening torque:

Axle nut:

105 Nm (10.5 m·kgf, 75 ft·lbf)

## Troubleshooting

Although Yamaha motorcycles receive a thorough inspection before shipment from the factory, trouble may occur during operation. Any problem in the fuel, compression, or ignition systems, for example, can cause poor starting and loss of power.

The following troubleshooting charts represent quick and easy procedures for checking these vital systems yourself. However, should your motorcycle require any repair, take it to a Yamaha dealer, whose skilled technicians have the necessary tools, experience, and know-how to service the motorcycle properly.

Use only genuine Yamaha replacement parts. Imitation parts may look like Yamaha parts, but they are often inferior, have a shorter service life and can lead to expensive repair bills.

## WARNING

**When checking the fuel system, do not smoke, and make sure there are no open flames or sparks in the area, including pilot lights from water heaters or furnaces. Gasoline or gasoline vapors can ignite or explode, causing severe injury or property damage.**

# PERIODIC MAINTENANCE AND ADJUSTMENT

EAU42131

## Troubleshooting charts

### Starting problems or poor engine performance

#### 1. Fuel

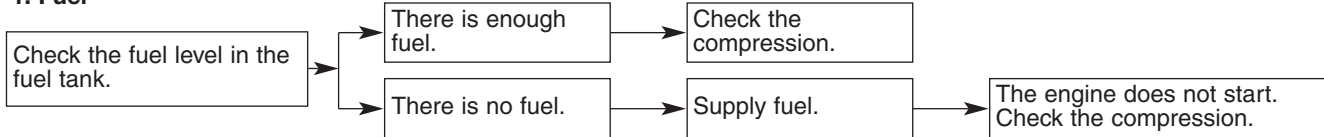

#### 2. Compression

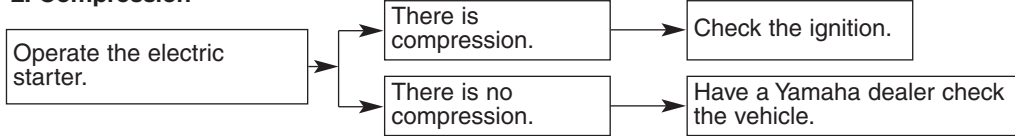

#### 3. Ignition

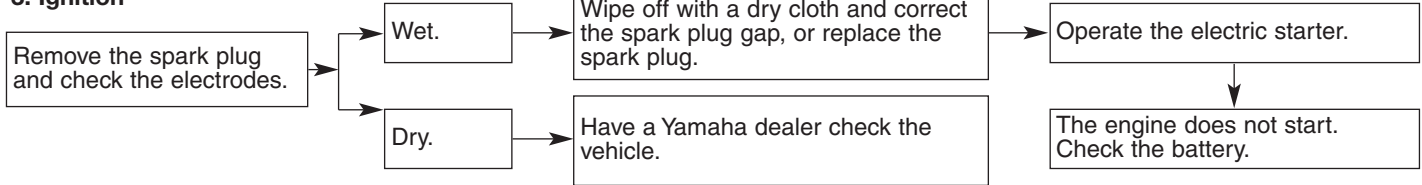

#### 4. Battery

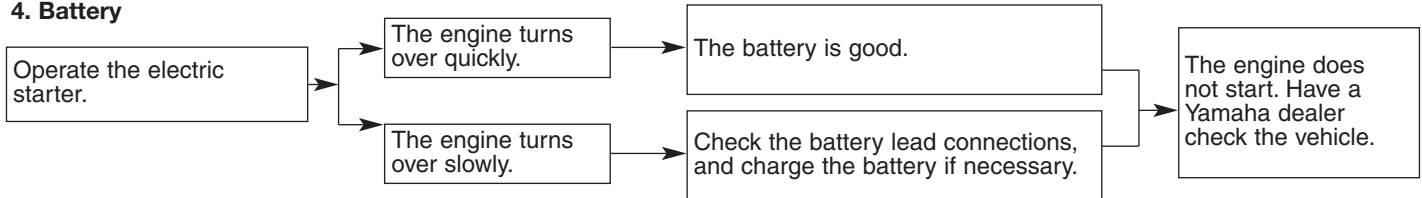

# PERIODIC MAINTENANCE AND ADJUSTMENT

## Engine overheating

EWA10400

### **⚠ WARNING**

- Do not remove the radiator cap when the engine and radiator are hot. Scalding hot fluid and steam may be blown out under pressure, which could cause serious injury. Be sure to wait until the engine has cooled.
- After removing the radiator cap retaining bolt, place a thick rag, like a towel, over the radiator cap, and then slowly rotate the cap counterclockwise to the detent to allow any residual pressure to escape. When the hissing sound has stopped, press down on the cap while turning it counterclockwise, and then remove the cap.

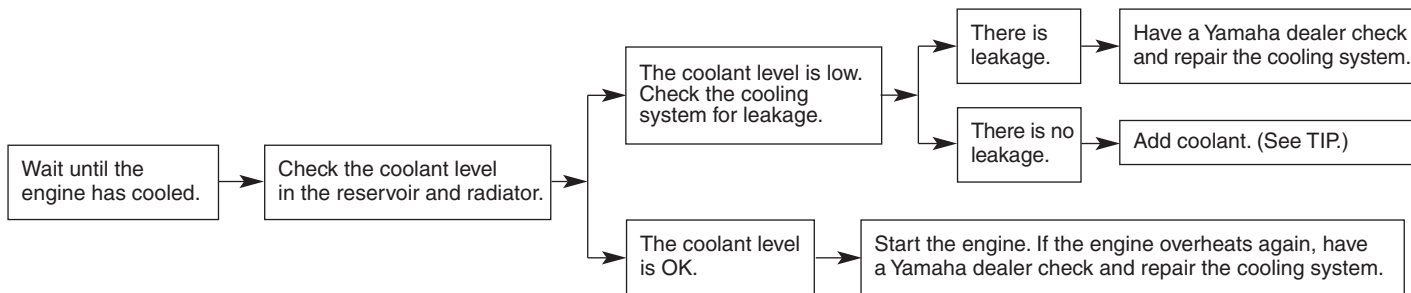

### **TIP**

If coolant is not available, tap water can be temporarily used instead, provided that it is changed to the recommended coolant as soon as possible.

# MOTORCYCLE CARE AND STORAGE

EAU26004

## Care

While the open design of a motorcycle reveals the attractiveness of the technology, it also makes it more vulnerable. Rust and corrosion can develop even if high-quality components are used. A rusty exhaust pipe may go unnoticed on a car, however, it detracts from the overall appearance of a motorcycle. Frequent and proper care does not only comply with the terms of the warranty, but it will also keep your motorcycle looking good, extend its life and optimize its performance.

## Before cleaning

1. Cover the muffler outlet with a plastic bag after the engine has cooled down.
2. Make sure that all caps and covers as well as all electrical couplers and connectors, including the spark plug cap, are tightly installed.

3. Remove extremely stubborn dirt, like oil burnt onto the crankcase, with a degreasing agent and a brush, but never apply such products onto seals, gaskets, sprockets, the drive chain and wheel axles. Always rinse the dirt and degreaser off with water.

## Cleaning

ECA10772

### NOTICE

- **Avoid using strong acidic wheel cleaners, especially on spoked wheels. If such products are used on hard-to-remove dirt, do not leave the cleaner on the affected area any longer than instructed. Also, thoroughly rinse the area off with water, immediately dry it, and then apply a corrosion protection spray.**
  - **Improper cleaning can damage plastic parts (such as cowlings, panels, windshields, headlight lenses, meter lenses, etc.) and the mufflers. Use only a soft, clean cloth or sponge with wa-**
- ter to clean plastic. However, if the plastic parts cannot be thoroughly cleaned with water, diluted mild detergent with water may be used. Be sure to rinse off any detergent residue using plenty of water, as it is harmful to plastic parts.
- **Do not use any harsh chemical products on plastic parts. Be sure to avoid using cloths or sponges which have been in contact with strong or abrasive cleaning products, solvent or thinner, fuel (gasoline), rust removers or inhibitors, brake fluid, antifreeze or electrolyte.**
  - **Do not use high-pressure washers or steam-jet cleaners since they cause water seepage and deterioration in the following areas: seals (of wheel and swingarm bearings, fork and brakes), electric components (couplers, connectors, instruments, switches and lights), breather hoses and vents.**

# MOTORCYCLE CARE AND STORAGE

---

- For motorcycles equipped with a windshield: Do not use strong cleaners or hard sponges as they will cause dulling or scratching. Some cleaning compounds for plastic may leave scratches on the windshield. Test the product on a small hidden part of the windshield to make sure that it does not leave any marks. If the windshield is scratched, use a quality plastic polishing compound after washing.
- 

## After normal use

Remove dirt with warm water, a mild detergent, and a soft, clean sponge, and then rinse thoroughly with clean water. Use a toothbrush or bottlebrush for hard-to-reach areas. Stubborn dirt and insects will come off more easily if the area is covered with a wet cloth for a few minutes before cleaning.

## After riding in the rain, near the sea or on salt-sprayed roads

Since sea salt or salt sprayed on roads during winter are extremely corrosive in combination with water, carry out the following steps after each ride in the rain, near the sea or on salt-sprayed roads.

## **TIP** \_\_\_\_\_

Salt sprayed on roads in the winter may remain well into spring.

---

1. Clean the motorcycle with cold water and a mild detergent, after the engine has cooled down. **NO-TICE: Do not use warm water since it increases the corrosive action of the salt.**

2. Apply a corrosion protection spray on all metal, including chrome- and nickel-plated, surfaces to prevent corrosion.

## **After cleaning**

1. Dry the motorcycle with a chamois or an absorbing cloth.
2. Immediately dry the drive chain and lubricate it to prevent it from rusting.
3. Use a chrome polish to shine chrome, aluminum and stainless-steel parts, including the exhaust system. (Even the thermally induced discoloring of stainless-steel exhaust systems can be removed through polishing.)
4. To prevent corrosion, it is recommended to apply a corrosion protection spray on all metal, including chrome- and nickel-plated, surfaces.
5. Use spray oil as a universal cleaner to remove any remaining dirt.
6. Touch up minor paint damage caused by stones, etc.
7. Wax all painted surfaces.

# MOTORCYCLE CARE AND STORAGE

---

8. Let the motorcycle dry completely before storing or covering it.

EWA11131

## WARNING

Contaminants on the brakes or tires can cause loss of control.

- Make sure that there is no oil or wax on the brakes or tires.
  - If necessary, clean the brake discs and brake linings with a regular brake disc cleaner or acetone, and wash the tires with warm water and a mild detergent. Before riding at higher speeds, test the motorcycle's braking performance and cornering behavior.
- 

## NOTICE

ECA10800

- Apply spray oil and wax sparingly and make sure to wipe off any excess
  - Never apply oil or wax to any rubber and plastic parts, but treat them with a suitable care product.
  - Avoid using abrasive polishing compounds as they will wear away the paint.
- 

## TIP

- Consult a Yamaha dealer for advice on what products to use.
  - Washing, rainy weather or humid climates can cause the headlight lens to fog. Turning the headlight on for a short period of time will help remove the moisture from the lens.
- 

EAUM1901

## Storage

### Short-term

Always store your motorcycle in a cool, dry place and, if necessary, protect it against dust with a porous cover.

ECA10810

## NOTICE

- Storing the motorcycle in a poorly ventilated room or covering it with a tarp, while it is still wet, will allow water and humidity to seep in and cause rust.
  - To prevent corrosion, avoid damp cellars, stables (because of the presence of ammonia) and areas where strong chemicals are stored.
-

# MOTORCYCLE CARE AND STORAGE

## Long-term

Before storing your motorcycle for several months:

1. Follow all the instructions in the “Care” section of this chapter.
2. Fill up the fuel tank and add fuel stabilizer (if available) to prevent the fuel tank from rusting and the fuel from deteriorating.
3. Perform the following steps to protect the cylinder, piston rings, etc. from corrosion.
  - a. Remove the spark plug cap and spark plug.
  - b. Pour a teaspoonful of engine oil into the spark plug bore.
  - c. Install the spark plug cap onto the spark plug, and then place the spark plug on the cylinder head so that the electrodes are grounded. (This will limit sparking during the next step.)
  - d. Turn the engine over several times with the starter. (This will coat the cylinder wall with oil.)
  - e. Remove the spark plug cap from the spark plug, and then install the spark plug and the spark plug cap. **WARNING! To prevent damage or injury from sparking, make sure to ground the spark plug electrodes while turning the engine over.**
4. Lubricate all control cables and the pivoting points of all levers and pedals as well as of the side-stand/centerstand.
5. Check and, if necessary, correct the tire air pressure, and then lift the motorcycle so that both of its wheels are off the ground. Alternatively, turn the wheels a little every month in order to prevent the tires from becoming degraded in one spot.
6. Cover the muffler outlets with plastic bags to prevent moisture from entering them.
7. Remove the battery and fully charge it. Store it in a cool, dry place and charge it once a month. Do not store the battery in an excessively cold or warm place [less than 0 °C (30 °F) or more than 30 °C (90 °F)]. For more information on storing the battery, see page 7-31.

## TIP

Make any necessary repairs before storing the motorcycle.

# SPECIFICATIONS

## Dimensions:

- Overall length:  
2246 mm (88.42 in)
- Overall width:  
864 mm (34.01 in)
- Overall height:  
1477 mm (58.14 in)
- Seat height:  
896 mm (35.27 in)
- Wheelbase:  
1500 mm (59.05 in)
- Ground clearance:  
260 mm (10.23 in)
- Minimum turning radius:  
1958 mm (77.08 in)

## Basic weight:

- With oil and fuel:  
208.5 kg (459 lb)

## Engine:

- Engine type:  
Liquid cooled 4-stroke, SOHC
- Cylinder arrangement:  
Forward-inclined single cylinder
- Displacement:  
660.0 cm<sup>3</sup> (40.27 cu.in)
- Bore x stroke:  
100.0 x 84.0 mm (3.94 x 3.31 in)
- Compression ratio:  
10.00 : 1
- Starting system:  
Electric starter
- Lubrication system:  
Dry sump

## Engine oil:

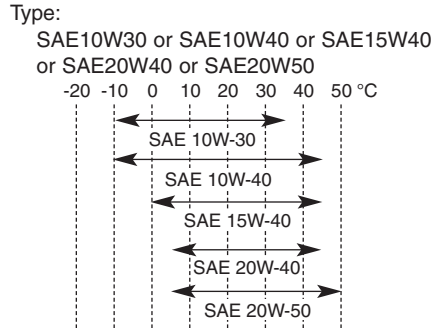

- Recommended engine oil grade:  
API service SE, SF, SG type or higher
- Engine oil quantity:  
Without oil filter element replacement:  
2.50 L (2.64 US qt) (2.19 Imp.qt)
- With oil filter element replacement:  
2.60 L (2.73 US qt) (2.26 Imp.qt)
- Total amount (dry engine):  
2.90 L (3.07 US qt) (2.55 Imp.qt)

## Cooling system:

- Radiator capacity (including all routes):  
1.2 L (1.26 US qt) (1.05 Imp.qt) (Radiator) +  
0.5 L (0.52 US qt) (0.44 Imp.qt)  
(Coolant reservoir)
- Coolant reservoir capacity (up to the maximum level mark):  
0.50 L (0.52 US qt) (0.44 Imp.qt)
- From low to full level:  
0.30 L (0.32 US qt) (0.26 Imp.qt)

## Air filter:

- Air filter element:  
Paper

## Fuel:

- Recommended fuel:  
Premium unleaded gasoline only
- Fuel tank capacity:  
23.0 L (6.07 US gal) (5.06 Imp.gal)
- Fuel reserve amount:  
6.7 L (1.76 US gal) (1.46 Imp.gal)

## Fuel injection:

- Manufacturer:  
DENSO
- Model:  
297500-0390

## Spark plug:

- Manufacturer/model:  
NGK/CR7E
- Gap:  
0.7-0.8 mm (0.028-0.032 in)

## Clutch:

- Clutch type:  
Wet, multiple-disc

## Transmission:

- Primary reduction system:  
Spur gear
- Primary reduction ratio:  
75/36 (2.083)
- Secondary reduction system:  
Chain drive
- Secondary reduction ratio:  
45/15 (3.00)
- Transmission type:  
Constant mesh 5-speed



**Operation:**

Left foot operation

**Gear ratio:**

- 1<sup>st</sup>: 30/12 (2.500)
- 2<sup>nd</sup>: 26/16 (1.625)
- 3<sup>rd</sup>: 23/20 (1.150)
- 4<sup>th</sup>: 20/22 (0.909)
- 5<sup>th</sup>: 20/26 (0.769)

**Chassis:**

Frame type:

Diamond

Caster angle:

28°

Trail:

113.0 mm (4.44 in)

**Front tire:**

Type:

With tube

Size:

90/90-21M/C 54S,  
90/90-21M/C 54T

Manufacturer/model:

METZELER/TOURANCE FRONT  
MICHELIN/SIRAC

**Rear tire:**

Type:

With tube

Size:

130/80-17M/C 65S,  
130/80-17M/C 65T

Manufacturer/model:

METZELER/TOURANCE  
MICHELIN/SIRAC A

**Load:**

Maximum load:

190 kg (419 lb)

(Total weight of rider, passenger, cargo  
and accessories)

**Tire air pressure****(measured on cold tires):**

Load:

Up to 90 kg (0-198 lb)

Front:

210 kPa (30 psi) (2.1 kgf/cm<sup>2</sup>)

Rear:

230 kPa (33 psi) (2.3 kgf/cm<sup>2</sup>)

Load:

90-190 kg (198-419 lb)

Front:

230 kPa (33 psi) (2.3 kgf/cm<sup>2</sup>)

Rear:

250 kPa (36 psi) (2.5 kgf/cm<sup>2</sup>)

Off-road riding:

Front:

200 kPa (29 psi) (2.0 kgf/cm<sup>2</sup>)

Rear:

200 kPa (29 psi) (2.0 kgf/cm<sup>2</sup>)

High-speed riding:

Front:

210 kPa (30 psi) (2.1 kgf/cm<sup>2</sup>)

Rear:

230 kPa (33 psi) (2.3 kgf/cm<sup>2</sup>)

9-2

**Front wheel:**

Type:

Spoke wheel

Rim size:

21 x 1.85

**Rear wheel:**

Type:

Spoke wheel

Rim size:

17M/C x MT2.75

**Front brake:**

Type:

Dual disc brake

Operation:

Right hand

Fluid:

DOT 4

**Rear brake:**

Type:

Single disc brake

Operation:

Right foot

Fluid:

DOT 4

**Front suspension:**

Type:

Telescopic fork

Spring/damper type:

Coil spring/oil damper

Wheel travel:

210 mm (8.26 in)

# SPECIFICATIONS

---

## Rear suspension:

- Type:
  - Swingarm (link suspension)
- Spring/damper type:
  - Coil spring/gas-oil damper, spring preload adjustable
- Wheel travel:
  - 200 mm (7.87 in)

## Electrical system:

- Ignition system:
  - Transistorized coil ignition (digital)
- Charging system:
  - A.C. magneto

## Battery:

- Model:
  - GT9B-4
- Voltage, capacity:
  - 12 V, 8 Ah

## Headlight:

- Bulb type:
  - Halogen bulb

## Bulb voltage, wattage x quantity:

- Headlight:
  - 12 V, 55 W x 2
- Auxiliary light:
  - 12 V, 5 W x 2
- Tail/brake light:
  - LED
- Front turn signal light:
  - 12 V, 10 W x 2
- Rear turn signal light:
  - 12 V, 10 W x 2
- Meter lighting:
  - LED (backlight)

- Neutral indicator light:
  - LED
- Turn signal indicator light:
  - LED
- High beam indicator light:
  - LED
- Coolant temperature warning light:
  - LED
- Engine trouble warning light:
  - LED
- Immobilizer system indicator light:
  - LED

## Fuses:

- Main fuse:
  - 30 A
- Headlight fuse:
  - 20 A
- Signaling system fuse:
  - 10 A
- Ignition fuse:
  - 10 A
- Parking lighting fuse:
  - 10 A
- Radiator fan fuse:
  - 7.5 A
- Fuel injection system fuse:
  - 10 A
- Backup fuse (for odometer, clock and immobilizer):
  - 10 A

EAU26351

EAU26400

EAU26520

## Identification numbers

Record the key identification number, vehicle identification number and model label information in the spaces provided below for assistance when ordering spare parts from a Yamaha dealer or for reference in case the vehicle is stolen.

KEY IDENTIFICATION NUMBER:

VEHICLE IDENTIFICATION NUMBER:

MODEL LABEL INFORMATION:

## Vehicle identification number

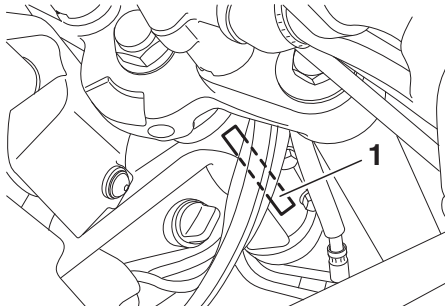

1. Vehicle identification number

The vehicle identification number is stamped into the steering head pipe. Record this number in the space provided.

**NOTE:** \_\_\_\_\_

The vehicle identification number is used to identify your motorcycle and may be used to register your motorcycle with the licensing authority in your area

---

## Model label

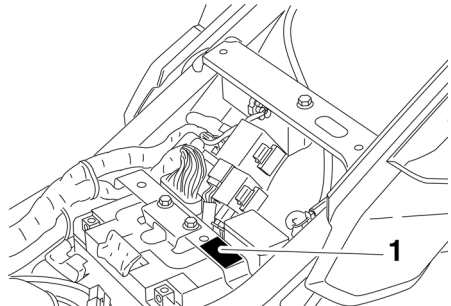

1. Model label

The model label is affixed to the frame under the seat. (See page 4-14.) Record the information on this label in the space provided. This information will be needed when ordering spare parts from a Yamaha dealer.

# CONSUMER INFORMATION

---

EAU26570

## Motorcycle noise regulation (for Australia)

### TAMPERING WITH NOISE CONTROL SYSTEM PROHIBITED:

Owners are warned that the law may prohibit:

- a. The removal or rendering inoperative by any person other than for purposes of maintenance, repair or replacement, of any device or element of design incorporated into any new vehicle for the purpose of noise control prior to its sale or delivery to the ultimate purchaser or while it is in use; and
- b. The use of the vehicle after such device or element of design has been removed or rendered inoperative by any person.

# INDEX

- A**  
Aftermarket Parts, Accessories, and Modifications.....2-4  
Aftermarket Tires and Rims .....2-4  
Air filter element, cleaning the check hose .....7-14  
Air filter element, replacing .....7-14  
Auxiliary light bulb, replacing.....7-35  
Avoid Carbon Monoxide poisoning ....2-2
- B**  
Battery.....7-30  
    To access the battery .....7-30  
    To charge the battery.....7-30  
    To store the battery.....7-31  
Be a Responsible Owner .....2-1  
Brake and clutch levers, checking and lubricating .....7-26  
Brake fluid .....7-22  
    Changing .....7-23  
    Checking fluid level.....7-22  
Brake lever .....4-11  
Brake pads, checking.....7-21  
Brake pedal .....4-11  
    Checking.....7-27  
    Lubricating .....7-27
- C**  
Cables, checking and lubricating .....7-25  
Carbon Monoxide (avoid Carbon Monoxide poisoning).....2-2  
Care and storage .....8-1  
Catalytic converter .....4-13  
Checking and lubricating the brake and clutch levers.....7-26  
Checking and lubricating the brake pedal .....7-27  
Checking and lubricating the cables..7-25  
Checking and lubricating the sidestand .....7-27  
Checking and lubricating the throttle grip and cable .....7-26  
Checking the brake pedal .....7-27  
Checking the sidestand switch.....4-18  
Clock mode .....4-7  
Clutch lever .....4-10  
Clutch lever free play, adjusting .....7-20  
Consumer information.....10-1  
Controls and instruments .....3-3  
    Function .....4-1  
Coolant.....7-12  
Coolant temperature warning light....4-4
- D**  
Description .....3-1  
    Controls and instrument .....3-3  
    Left view.....3-1  
    Right view .....3-2  
Dimmer switch.....4-9  
Drive chain, cleaning and lubricating .....7-25  
Drive chain slack .....7-23  
    Adjusting.....7-23  
    Checking.....7-23  
Cleaning and lubricating .....7-25
- E**  
Emission control system (periodic maintenance chart).....7-2  
Engine break-in .....6-3  
Engine idling speed, adjusting .....7-15  
Engine oil and oil filter element.....7-9  
Engine oil filter element.....7-10  
Engine stop switch .....4-9  
Engine trouble warning light.....4-4
- F**  
For your safety - Pre-operation checks.....5-1  
Front fork.....4-15  
    Adjusting .....4-15  
    Checking.....7-28  
Front wheel .....7-36  
    Installing.....7-37  
    Removing.....7-36  
Fuel .....4-12  
Fuel consumption, tips for reducing...6-3  
Fuel meter.....4-7  
Fuel tank breather hose.....4-13  
Fuel tank cap .....4-11  
Fuses, replacing.....7-31
- G**  
Genuine Yamaha Accessories .....2-3
- H**  
Handlebar switches.....4-9

# INDEX

---

- Dimmer switch .....4-9
- Engine stop switch.....4-9
- Hazard switch .....4-10
- Horn switch.....4-9
- Pass switch.....4-9
- Start switch .....4-9
- Turn signal switch .....4-9
- Headlight bulb, replacing .....7-33
- High beam indicator light .....4-4
- Horn switch .....4-9
- I**
- Identification numbers .....10-1
- Idling speed, checking .....7-15
- Ignition circuit cut-off system.....4-17
  - Checking operation procedure .....4-18
- Immobilizer system .....4-1
- Immobilizer system indicator light .....4-4
- Indicator and warning lights .....4-3
  - Coolant temperature warning light .....4-4
  - Engine trouble warning light .....4-4
  - High beam indicator light.....4-4
  - Immobilizer system indicator light .....4-4
  - Neutral indicator light.....4-4
  - Turn signal indicator light.....4-3
- Instruments .....4-3
- Instrument and control functions.....4-1
- K**
- Keys .....4-1
- L**
- Labels (location of important labels) ..1-1
- License plate light bulb, replacing....7-35
- Location of important labels .....1-1
- Loading .....2-3
- Lubricating the brake and clutch levers.....7-26
- Lubricating the brake pedal.....7-27
- Lubricating the cables .....7-25
- Lubricating the drive chain.....7-25
- Lubricating the sidestand .....7-27
- Lubricating the throttle grip and cable .....7-26
- Lubricating the swingarm pivots.....7-28
- M**
- Main switch/steering lock .....4-2
- Model label.....10-1
- Motorcycle noise regulation (for Australia) .....10-2
- Multi-function display.....4-5
  - Clock mode.....4-7
  - Self-diagnosis devices .....4-7
  - Tachometer .....4-6
  - Tripmeter and tachometer modes ..4-6
- N**
- Neutral indicator light .....4-4
- O**
- Oil filter element .....7-10
- Operation and important riding points .....6-1
- Owner's tool kit .....7-1
- P**
- Panels, removing and installing .....7-6
- Parking .....6-4
- Pass switch .....4-9
- Periodic maintenance and adjustment .....7-1
- Periodic maintenance chart for the emission control system .....7-2
- Pre-operation check list .....5-2
- Pre-operation checks .....5-1
- R**
- Rear suspension, lubricating.....7-27
- Rear wheel .....7-38
  - Installing.....7-39
  - Removing.....7-38
- Record the identification numbers ...10-1
- S**
- Safety information .....2-1
- Seat .....4-14
- Self-diagnosis devices .....4-7
- Shift pedal .....4-10
- Shifting .....6-2
- Shock absorber assembly (adjusting) .....4-16
- Sidestand .....4-17
- Sidestand, checking and lubricating .....7-27
- Sidestand switch, checking .....4-18
- Spark plug, checking.....7-8

Specifications .....	9-1
Spoke wheels .....	7-19
Start switch .....	4-9
Starting the engine.....	6-1
Steering, checking.....	7-29
Steering lock .....	4-2
Storage.....	8-3
Supporting the motorcycle .....	7-36
Swingarm, lubricating the pivots .....	7-28

## T

Tachometer .....	4-6
Throttle cable free play, checking.....	7-16
Throttle grip and cable, checking and lubricating .....	7-26
Tips for reducing fuel consumption ....	6-3
Tires .....	7-16
Air pressure .....	7-16
Tire information.....	7-18
Tire inspection .....	7-18
Tool kit.....	7-1
Tripmeter and tachometer modes .....	4-6
Troubleshooting .....	7-39
Troubleshooting charts .....	7-40
Engine overheating.....	7-41
Turn signal indicator light .....	4-3
Turn signal light bulb, replacing.....	7-34
Turn signal switch.....	4-9

## V

Valve clearance .....	7-16
Vehicle identification number .....	10-1

## W

Warning lights .....	4-3
Wheel bearings, checking.....	7-29
Wheels, spoke.....	7-19













**MBK Industrie**

**Z.I. de Rouvroy 02100 Saint Quentin**

Société Anonyme au capital de 45 000 000 €

R.C St-Quentin B 329 035 422

PRINTED IN FRANCE  
2012-03 (E)