



OWNER'S MANUAL

***WR250R***

***WR250R***

32D-28199-E0



Welcome to the Yamaha world of motorcycling!

As the owner of the WR250R, you are benefiting from Yamaha's vast experience and newest technology regarding the design and manufacture of high-quality products, which have earned Yamaha a reputation for dependability.

Please take the time to read this manual thoroughly, so as to enjoy all advantages of your WR250R. The owner's manual does not only instruct you in how to operate, inspect and maintain your motorcycle, but also in how to safeguard yourself and others from trouble and injury.

In addition, the many tips given in this manual will help keep your motorcycle in the best possible condition. If you have any further questions, do not hesitate to contact your Yamaha dealer.

The Yamaha team wishes you many safe and pleasant rides. So, remember to put safety first!



# IMPORTANT MANUAL INFORMATION

---

---

EAU10151

Particularly important information is distinguished in this manual by the following notations:

	<b>The Safety Alert Symbol means ATTENTION! BECOME ALERT! YOUR SAFETY IS INVOLVED!</b>
	<b>Failure to follow WARNING instructions <u>could result in severe injury or death to the motorcycle operator, a bystander, or a person inspecting or repairing the motorcycle.</u></b>
<b>CAUTION:</b>	<b>A CAUTION indicates special precautions that must be taken to avoid damage to the motorcycle.</b>
<b>NOTE:</b>	A NOTE provides key information to make procedures easier or clearer.

## NOTE:

- This manual should be considered a permanent part of this motorcycle and should remain with it even if the motorcycle is subsequently sold.
- Yamaha continually seeks advancements in product design and quality. Therefore, while this manual contains the most current product information available at the time of printing, there may be minor discrepancies between your motorcycle and this manual. If you have any questions concerning this manual, please consult your Yamaha dealer.

EWA10030

## **WARNING**

**PLEASE READ THIS MANUAL CAREFULLY AND COMPLETELY BEFORE OPERATING THIS MOTORCYCLE.**

---

\*Product and specifications are subject to change without notice.

# **IMPORTANT MANUAL INFORMATION**

---

EAU10200

**WR250R  
OWNER'S MANUAL  
©2007 by Yamaha Motor Co., Ltd.  
1st edition, September 2007  
All rights reserved.  
Any reprinting or unauthorized use  
without the written permission of  
Yamaha Motor Co., Ltd.  
is expressly prohibited.  
Printed in Japan.**

# TABLE OF CONTENTS

---

---

<b>SAFETY INFORMATION</b> .....	1-1	<b>PRE-OPERATION CHECKS</b> .....	4-1	Adjusting the clutch lever free play .....	6-21
<b>DESCRIPTION</b> .....	2-1	Pre-operation check list .....	4-2	Adjusting the brake lever free play .....	6-22
Left view .....	2-1	<b>OPERATION AND IMPORTANT</b>		Adjusting the rear brake light switch .....	6-22
Right view .....	2-2	<b>RIDING POINTS</b> .....	5-1	Checking the front and rear brake pads .....	6-23
Controls and instruments.....	2-3	Starting the engine .....	5-1	Checking the brake fluid level .....	6-23
<b>INSTRUMENT AND CONTROL</b>		Shifting .....	5-2	Changing the brake fluid .....	6-24
<b>FUNCTIONS</b> .....	3-1	Tips for reducing fuel consumption .....	5-3	Drive chain slack .....	6-25
Main switch/steering lock .....	3-1	Engine break-in .....	5-3	Cleaning and lubricating the drive chain .....	6-26
Indicator and warning lights .....	3-2	Parking .....	5-4	Checking and lubricating the cables .....	6-27
Multi-function display .....	3-3	<b>PERIODIC MAINTENANCE AND</b>		Checking and lubricating the throttle grip and cable .....	6-27
Handlebar switches .....	3-8	<b>MINOR REPAIR</b> .....	6-1	Checking and lubricating the brake and shift pedals .....	6-27
Clutch lever .....	3-9	Owner's tool kit .....	6-1	Checking and lubricating the brake and clutch levers .....	6-28
Shift pedal .....	3-10	Periodic maintenance and lubrication chart .....	6-2	Checking and lubricating the sidestand .....	6-29
Brake lever .....	3-10	Removing and installing panels .....	6-6	Lubricating the rear suspension ....	6-29
Brake pedal .....	3-10	Checking the spark plug .....	6-8	Checking the front fork .....	6-29
Fuel tank cap .....	3-11	Engine oil and oil filter element .....	6-9	Checking the steering .....	6-30
Fuel .....	3-11	Coolant .....	6-12	Checking the wheel bearings .....	6-31
Catalytic converter .....	3-12	Cleaning the air filter element and check hose .....	6-15	Battery .....	6-31
Seat .....	3-12	Adjusting the engine idling speed .....	6-17	Replacing the fuses .....	6-32
Helmet holder .....	3-13	Checking the throttle cable free play .....	6-18	Replacing the headlight bulb .....	6-33
Adjusting the front fork .....	3-13	Valve clearance .....	6-18	Tail/brake light .....	6-35
Front fork bleeding .....	3-15	Tires .....	6-18		
Adjusting the shock absorber assembly .....	3-15	Spoke wheels .....	6-20		
EXUP system .....	3-17				
Sidestand .....	3-18				
Ignition circuit cut-off system .....	3-18				

# TABLE OF CONTENTS

---

---

Replacing a turn signal light bulb ..	6-35
Replacing the license plate light bulb .....	6-36
Replacing an auxiliary light bulb ....	6-36
Supporting the motorcycle .....	6-37
Front wheel .....	6-37
Rear wheel .....	6-38
Troubleshooting .....	6-40
Troubleshooting charts .....	6-41

## **MOTORCYCLE CARE AND**

<b>STORAGE</b> .....	7-1
Matte color caution .....	7-1
Care .....	7-1
Storage .....	7-3

<b>SPECIFICATIONS</b> .....	8-1
-----------------------------	-----

<b>CONSUMER INFORMATION</b> .....	9-1
Identification numbers .....	9-1

# SAFETY INFORMATION

EAUW0200

1

MOTORCYCLES ARE SINGLE TRACK VEHICLES. THEIR SAFE USE AND OPERATION ARE DEPENDENT UPON THE USE OF PROPER RIDING TECHNIQUES AS WELL AS THE EXPERTISE OF THE OPERATOR. EVERY OPERATOR SHOULD KNOW THE FOLLOWING REQUIREMENTS BEFORE RIDING THIS MOTORCYCLE.

HE OR SHE SHOULD:

- OBTAIN THOROUGH INSTRUCTIONS FROM A COMPETENT SOURCE ON ALL ASPECTS OF MOTORCYCLE OPERATION.
- OBSERVE THE WARNINGS AND MAINTENANCE REQUIREMENTS IN THE OWNER'S MANUAL.
- OBTAIN QUALIFIED TRAINING IN SAFE AND PROPER RIDING TECHNIQUES.
- OBTAIN PROFESSIONAL TECHNICAL SERVICE AS INDICATED BY THE OWNER'S MANUAL AND/OR WHEN MADE NECESSARY BY MECHANICAL CONDI-

TIONS.

## Safe riding

- Always make pre-operation checks. Careful checks may help prevent an accident.
- This motorcycle is designed to carry the operator and a passenger.
- The failure of motorists to detect and recognize motorcycles in traffic is the predominating cause of automobile/motorcycle accidents. Many accidents have been caused by an automobile driver who did not see the motorcycle. Making yourself conspicuous appears to be very effective in reducing the chance of this type of accident.
- **Therefore:**
  - Wear a brightly colored jacket.
  - Use extra caution when you are approaching and passing through intersections, since intersections are the most likely places for motorcycle accidents to occur.
  - Ride where other motorists can see you. Avoid riding in another

- motorist's blind spot.
- Many accidents involve inexperienced operators. In fact, many operators who have been involved in accidents do not even have a current motorcycle license.
  - Make sure that you are qualified and that you only lend your motorcycle to other qualified operators.
  - Know your skills and limits. Staying within your limits may help you to avoid an accident.
  - We recommend that you practice riding your motorcycle where there is no traffic until you have become thoroughly familiar with the motorcycle and all of its controls.
- Many accidents have been caused by error of the motorcycle operator. A typical error made by the operator is veering wide on a turn due to EXCESSIVE SPEED or undercornering (insufficient lean angle for the speed).
  - Always obey the speed limit and never travel faster than warrant-



ed by road and traffic conditions.

- Always signal before turning or changing lanes. Make sure that other motorists can see you.
- The posture of the operator and passenger is important for proper control.
  - The operator should keep both hands on the handlebar and both feet on the operator footrests during operation to maintain control of the motorcycle.
  - The passenger should always hold onto the operator, the seat strap or grab bar, if equipped, with both hands and keep both feet on the passenger footrests.
  - Never carry a passenger unless he or she can firmly place both feet on the passenger footrests.
- Never ride under the influence of alcohol or other drugs.

### Protective apparel

The majority of fatalities from motorcycle accidents are the result of head injuries. The use of a safety helmet is the single most critical factor in the preven-

tion or reduction of head injuries.

- Always wear an approved helmet.
- Wear a face shield or goggles. Wind in your unprotected eyes could contribute to an impairment of vision that could delay seeing a hazard.
- The use of a jacket, heavy boots, trousers, gloves, etc., is effective in preventing or reducing abrasions or lacerations.
- Never wear loose-fitting clothes, otherwise they could catch on the control levers, footrests, or wheels and cause injury or an accident.
- Never touch the engine or exhaust system during or after operation. They become very hot and can cause burns. Always wear protective clothing that covers your legs, ankles, and feet.
- A passenger should also observe the above precautions.

### Modifications

Modifications made to this motorcycle not approved by Yamaha, or the removal of original equipment, may ren-

der the motorcycle unsafe for use and may cause severe personal injury. Modifications may also make your motorcycle illegal to use.

### Loading and accessories

Adding accessories or cargo to your motorcycle can adversely affect stability and handling if the weight distribution of the motorcycle is changed. To avoid the possibility of an accident, use extreme caution when adding cargo or accessories to your motorcycle. Use extra care when riding a motorcycle that has added cargo or accessories. Here are some general guidelines to follow if loading cargo or adding accessories to your motorcycle:

#### Loading

The total weight of the operator, passenger, accessories and cargo must not exceed the maximum load limit.

<b>Maximum load:</b> 185 kg (408 lb)
---

When loading within this weight limit, keep the following in mind:

# SAFETY INFORMATION

1

- Cargo and accessory weight should be kept as low and close to the motorcycle as possible. Make sure to distribute the weight as evenly as possible on both sides of the motorcycle to minimize imbalance or instability.
  - Shifting weights can create a sudden imbalance. Make sure that accessories and cargo are securely attached to the motorcycle before riding. Check accessory mounts and cargo restraints frequently.
  - Never attach any large or heavy items to the handlebar, front fork, or front fender. These items, including such cargo as sleeping bags, duffel bags, or tents, can create unstable handling or a slow steering response.
- stallation and use of non-Yamaha accessories. Use extreme caution when selecting and installing any accessories. Keep the following guidelines in mind, as well as those provided under “Loading” when mounting accessories.
- Never install accessories or carry cargo that would impair the performance of your motorcycle. Carefully inspect the accessory before using it to make sure that it does not in any way reduce ground clearance or cornering clearance, limit suspension travel, steering travel or control operation, or obscure lights or reflectors.
  - Accessories fitted to the handlebar or the front fork area can create instability due to improper weight distribution or aerodynamic changes. If accessories are added to the handlebar or front fork area, they must be as lightweight as possible and should be kept to a minimum.
  - Bulky or large accessories may seriously affect the stability of

the motorcycle due to aerodynamic effects. Wind may attempt to lift the motorcycle, or the motorcycle may become unstable in cross winds. These accessories may also cause instability when passing or being passed by large vehicles.

- Certain accessories can displace the operator from his or her normal riding position. This improper position limits the freedom of movement of the operator and may limit control ability, therefore, such accessories are not recommended.
- Use caution when adding electrical accessories. If electrical accessories exceed the capacity of the motorcycle’s electrical system, an electric failure could result, which could cause a dangerous loss of lights or engine power.

## Accessories

Genuine Yamaha accessories have been specifically designed for use on this motorcycle. Since Yamaha cannot test all other accessories that may be available, you must personally be responsible for the proper selection, in-

## **Gasoline and exhaust gas**

- **GASOLINE IS HIGHLY FLAMMABLE:**
  - Always turn the engine off when

refueling.

- Take care not to spill any gasoline on the engine or exhaust system when refueling.
  - Never refuel while smoking or in the vicinity of an open flame.
  - Never start the engine or let it run for any length of time in a closed area. The exhaust fumes are poisonous and may cause loss of consciousness and death within a short time. Always operate your motorcycle in an area that has adequate ventilation.
  - Always turn the engine off before leaving the motorcycle unattended and remove the key from the main switch. When parking the motorcycle, note the following:
    - The engine and exhaust system may be hot, therefore, park the motorcycle in a place where pedestrians or children are not likely to touch these hot areas.
    - Do not park the motorcycle on a slope or soft ground, otherwise it may fall over.
    - Do not park the motorcycle near
- a flammable source, (e.g., a kerosene heater, or near an open flame), otherwise it could catch fire.
  - When transporting the motorcycle in another vehicle, make sure that it is kept upright. If the motorcycle should lean over, gasoline may leak out of the fuel tank.
  - If you should swallow any gasoline, inhale a lot of gasoline vapor, or allow gasoline to get into your eyes, see your doctor immediately. If any gasoline spills on your skin or clothing, immediately wash the affected area with soap and water and change your clothes.

# DESCRIPTION

EAU10410

## Left view

2

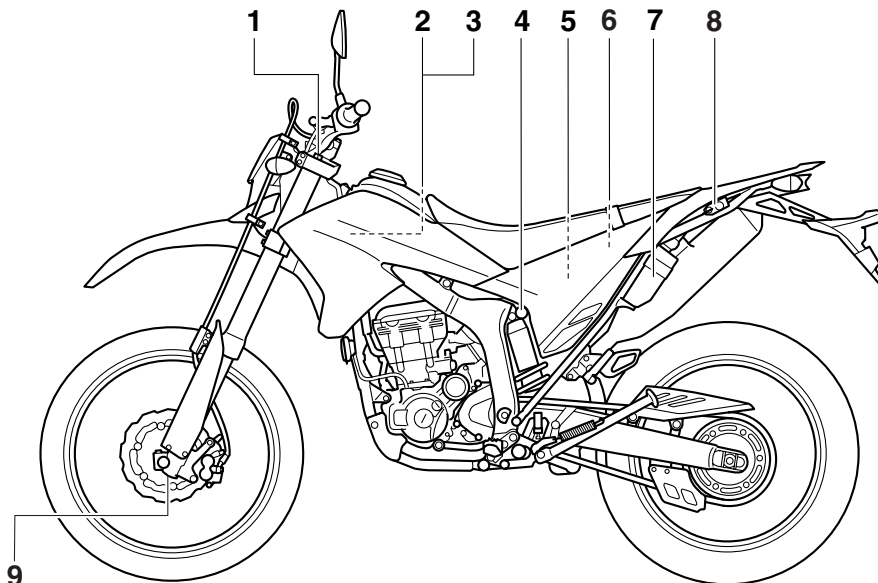

1. Front fork rebound damping force adjusting screw (page 3-13)
2. Fuse box (page 6-32)
3. Coolant reservoir (page 6-12)
4. Shock absorber assembly compression damping force adjusting screw (page 3-15)
5. Battery (page 6-31)
6. Main fuse (page 6-32)
7. Owner's tool kit (page 6-1)

8. Helmet holder (page 3-13)
9. Front fork compression damping force adjusting screw (page 3-13)

## Right view

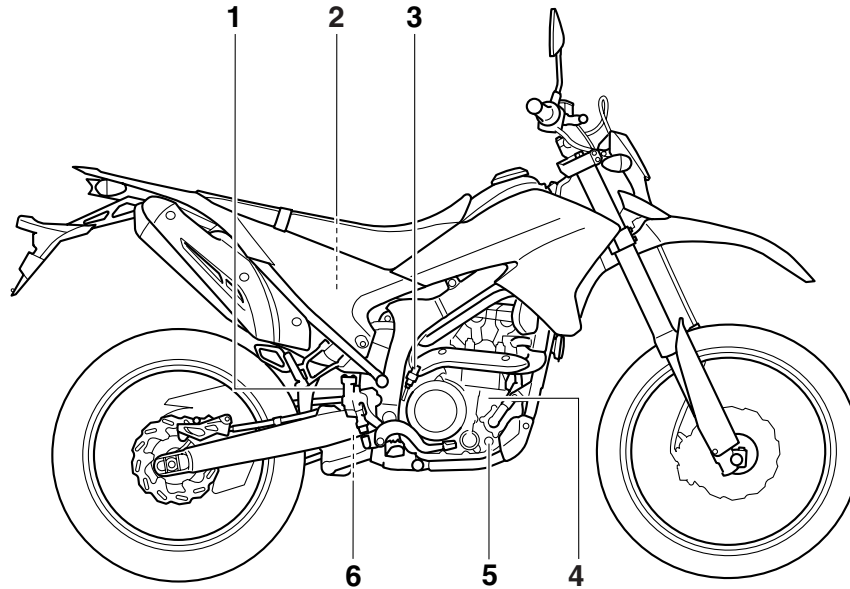

1. Rear brake fluid reservoir (page 6-23)
2. Air filter element (page 6-15)
3. Rear brake light switch (page 6-22)
4. Engine oil filler cap (page 6-9)
5. Engine oil level check window (page 6-9)
6. Shock absorber assembly rebound damping force adjusting dial (page 3-15)

# DESCRIPTION

EAU10430

## Controls and instruments

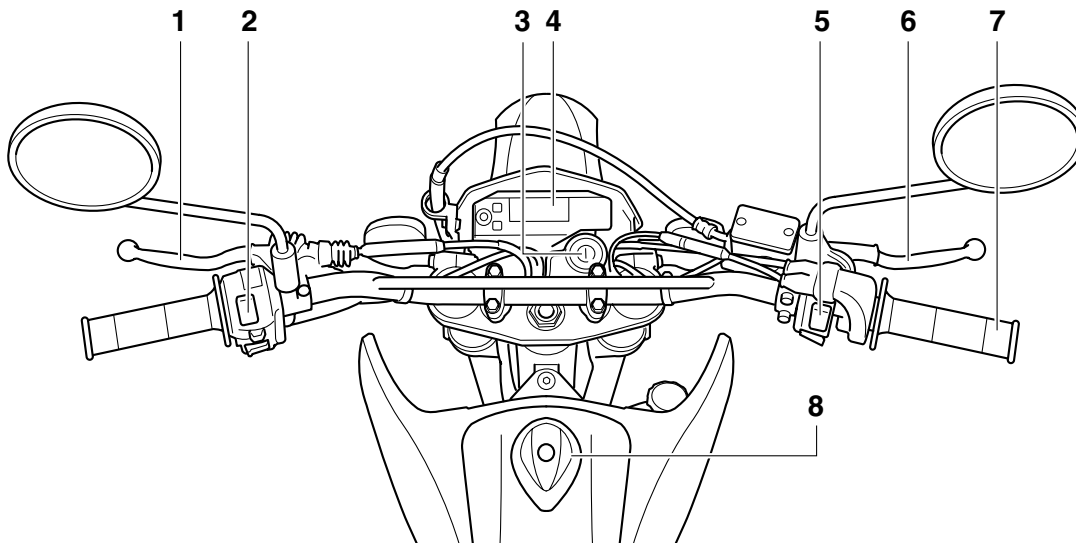

1. Clutch lever (page 3-9)
2. Left handlebar switches (page 3-8)
3. Main switch/steering lock (page 3-1)
4. Multi-function display (page 3-3)
5. Right handlebar switches (page 3-8)
6. Brake lever (page 3-10)
7. Throttle grip (page 6-18)
8. Fuel tank cap (page 3-11)

# INSTRUMENT AND CONTROL FUNCTIONS

## Main switch/steering lock

EAU10460

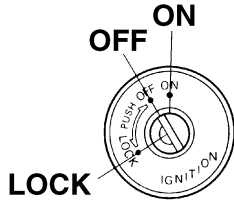

The main switch/steering lock controls the ignition and lighting systems, and is used to lock the steering. The various positions are described below.

### ON

EAU38530

All electrical circuits are supplied with power; the meter lighting, taillight, license plate light and auxiliary light come on, and the engine can be started. The key cannot be removed.

### NOTE:

The headlight comes on automatically when the engine is started and stays on until the key is turned to “OFF”, even if

the engine stalls.

EAU10660

### OFF

All electrical systems are off. The key can be removed.

EAU10680

### LOCK

The steering is locked, and all electrical systems are off. The key can be removed.

### To lock the steering

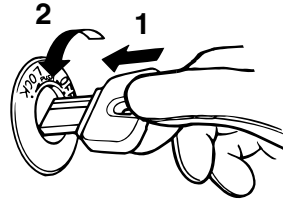

1. Push.
2. Turn.

1. Turn the handlebars all the way to the left.

2. Push the key in from the “OFF” position, and then turn it to “LOCK” while still pushing it.
3. Remove the key.

### To unlock the steering

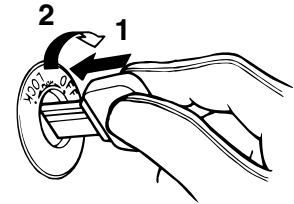

1. Push.
2. Turn.

Push the key in, and then turn it to “OFF” while still pushing it.

EWA10060

### **⚠ WARNING**

**Never turn the key to “OFF” or “LOCK” while the vehicle is moving, otherwise the electrical systems will be switched off, which may result in loss of control or an accident. Make sure that the vehicle is stopped be-**

# INSTRUMENT AND CONTROL FUNCTIONS





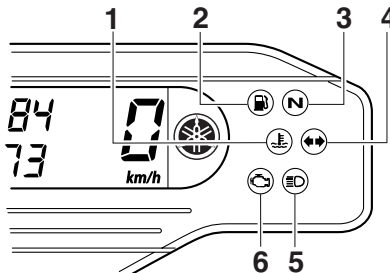

fore turning the key to “OFF” or “LOCK”.

3

## Indicator and warning lights

EAU11003



1. Coolant temperature warning light “”
2. Fuel level warning light “”
3. Neutral indicator light “**N**”
4. Turn signal indicator light “ ”
5. High beam indicator light “”
6. Engine trouble warning light “”

### Turn signal indicator light “ ”

EAU11020

This indicator light flashes when the turn signal switch is pushed to the left or right.

### Neutral indicator light “**N**”

EAU11060

This indicator light comes on when the

transmission is in the neutral position.

### High beam indicator light “”

EAU11080

This indicator light comes on when the high beam of the headlight is switched on.

### Fuel level warning light “”

EAU11350

This warning light comes on when the fuel level drops below approximately 2.1 L (0.55 US gal) (0.46 Imp.gal). When this occurs, refuel as soon as possible.

The electrical circuit of the warning light can be checked by turning the key to “ON”.

If the warning light does not come on for a few seconds, then go off, have a Yamaha dealer check the electrical circuit.

### Coolant temperature warning light “”

EAU11440

This warning light comes on when the engine overheats. When this occurs, stop the engine immediately and allow



# INSTRUMENT AND CONTROL FUNCTIONS

the engine to cool.

The electrical circuit of the warning light can be checked by turning the key to “ON”.

If the warning light does not come on for a few seconds, then go off, have a Yamaha dealer check the electrical circuit.

ECA10020

## CAUTION:

**Do not operate the engine if it is overheated.**

EAU43020

## Engine trouble warning light “”

This warning light comes on when an electrical circuit monitoring the engine is defective. When this occurs, have a Yamaha dealer check the self-diagnosis system.

The electrical circuit of the warning light can be checked by turning the key to “ON”. If the warning light does not come on for a few seconds, then go off, have a Yamaha dealer check the electrical circuit.

## NOTE:

This warning light will come on when

the key is turned to “ON” and the start switch is pushed, but this does not indicate a malfunction.

## Multi-function display

EAU45272

EWA12311



## WARNING

**Be sure to stop the vehicle before making any setting changes to the multi-function display.**

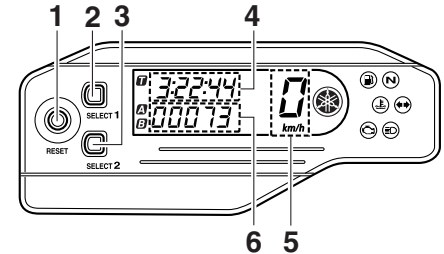

1. “RESET” button
2. “SELECT 1” button
3. “SELECT 2” button
4. Clock/stopwatch
5. Speedometer
6. Odometer/tripmeter/fuel reserve tripmeter

# INSTRUMENT AND CONTROL FUNCTIONS

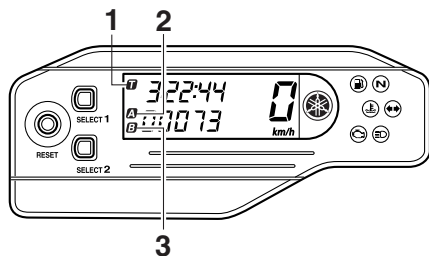

3

1. Stopwatch indicator “**T**”
2. Tripmeter A indicator “**A**”/  
Distance-compensation tripmeter “**A**”
3. Tripmeter B indicator “**B**”

## NOTE:

- The multi-function display can be set to the basic mode or the measurement mode.
- Tripmeter A will automatically reset to zero when changing from the basic mode to the measurement mode or vice versa.

## Basic mode:

- a speedometer (which shows the riding speed)
- an odometer (which shows the to-

tal distance traveled)

- two tripmeters (which show the distance traveled since they were last set to zero)
- a fuel reserve tripmeter (which shows the distance traveled since the fuel level warning light came on)
- a clock
- a self-diagnosis device

## Measurement mode:

- a speedometer (which shows the riding speed)
- a distance-compensation tripmeter (which shows the accumulated distance traveled since set to zero and which can be calibrated to provide a more accurate tripmeter reading)
- a stopwatch (which shows the time that has been accumulated since the start of stopwatch measurement)
- a self-diagnosis device

## NOTE:

- Be sure to turn the key to “ON” before using the “SELECT 1”,

“SELECT 2” and “RESET” buttons.

- When the key is turned to “ON”, all of the display segments of the multi-function display will appear and then disappear, in order to test the electrical circuit.
- For the U.K. only: To switch the speedometer and odometer/tripmeter displays between kilometers and miles, press the “SELECT 2” button until the display changes after the main switch is turned to “ON”.

## Basic mode

### Odometer and tripmeter modes

Push the “SELECT 2” button to switch the display between the odometer mode and the tripmeter modes A and B in the following order:  
odometer → tripmeter A → tripmeter B → odometer

# INSTRUMENT AND CONTROL FUNCTIONS

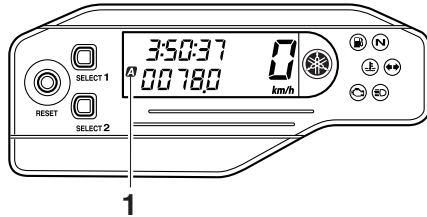

1. Tripmeter A indicator “A”

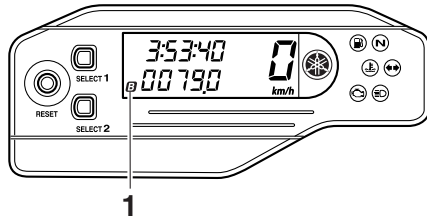

1. Tripmeter B indicator “B”

**NOTE:** \_\_\_\_\_

Indicator “A” comes on when tripmeter A is selected, and indicator “B” comes on when tripmeter B is selected.

If the fuel level warning light comes on (see page 3-2), the display will automatically change to the fuel reserve tripmeter mode “F” and start counting the distance traveled from that point. In this case, push the “SELECT 2” button to switch the display between the various tripmeter and odometer modes in the following order:

fuel reserve tripmeter “F” → odometer → tripmeter A → tripmeter B → fuel reserve tripmeter “F”

**NOTE:** \_\_\_\_\_

The fuel level warning light may not function accurately while riding off road as the fuel level reading changes due to the movement and inclination of the vehicle.

If the fuel level warning light comes on while riding in the measurement mode, change to the basic mode and push the “SELECT 2” button to display the fuel reserve tripmeter.

**NOTE:** \_\_\_\_\_

To change from the measurement mode to the basic mode, the stopwatch and the distance-compensation tripme-

ter must be stopped.

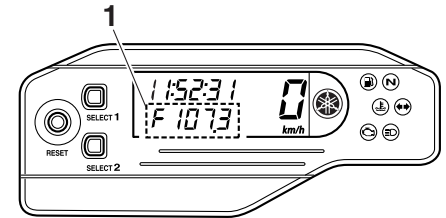

1. Fuel reserve tripmeter “F”

To reset a tripmeter, select it by pushing the “SELECT 2” button, and then push the “RESET” button for at least one second. If you do not reset the fuel reserve tripmeter manually, it will reset itself automatically and the display will return to the prior mode after refueling and traveling 5 km (3 mi).

Clock

Turn the key to “ON”.

**NOTE:** \_\_\_\_\_

When setting the clock, push the “SELECT 1” button to increase the digits or “SELECT 2” button to decrease

# INSTRUMENT AND CONTROL FUNCTIONS

the digits. Pushing and holding either button will increase or decrease the digits continuously until the button is released.

## To set the clock

1. Push the “SELECT 1” button for at least two seconds.
2. When the hour digits start flashing, push either select button to set the hours.
3. Push the “RESET” button, and the minute digits will start flashing.
4. Push either select button to set the minutes.
5. Push the “RESET” button, and the second digits will start flashing.
6. Push either select button to set the second digits to zero.
7. Push the “RESET” button for at least two seconds, and then release it to start the clock.

## NOTE:

If the “RESET” button is not pushed within 30 seconds, the clock will not be set and will return to the prior time.

## Changing from the basic mode to the measurement mode

With the odometer selected, push the “SELECT 1” button and “SELECT 2” button together for at least two seconds to change to the measurement mode.

## Changing from the measurement mode to the basic mode

### NOTE:

The stopwatch must be stopped before changing to the basic mode.

1. Check that the stopwatch is not in operation. If the stopwatch is in operation, stop it by pushing the “SELECT 1” button and “SELECT 2” button together.
2. Push the “SELECT 1” button and “SELECT 2” button together for at least two seconds to change to the basic mode.

## Measurement mode (for the stopwatch)

When the measurement mode is selected, the stopwatch is displayed and it can be started manually or automatically.

## Manual start

The manual start is the default setting for the stopwatch. The stopwatch indicator “**I**” and the distance-compensation tripmeter indicator “**A**” will start flashing.

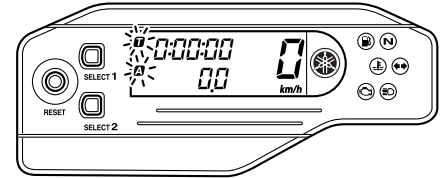

1. Push the “RESET” button to start the stopwatch.
2. Push the “SELECT 1” button and “SELECT 2” button together to stop the stopwatch.
3. To resume stopwatch counting, push the “SELECT 1” button and “SELECT 2” button together.

To reset the stopwatch to zero, see “Resetting the distance-compensation tripmeter or the distance-compensation tripmeter in combination with the stopwatch”

# INSTRUMENT AND CONTROL FUNCTIONS

on page 3-8.

**NOTE:** \_\_\_\_\_

The stopwatch will continue counting when the vehicle is stopped. To stop and/or resume counting, repeat steps 2 and 3.

Auto start

1. Push the “SELECT 1” button for at least two seconds to set the auto start.

**NOTE:** \_\_\_\_\_

When the stopwatch is set to auto start, the stopwatch indicator “**I**” and the distance-compensation tripmeter indicator “**A**” will start flashing, and the digits in the display will start scrolling from left to right.

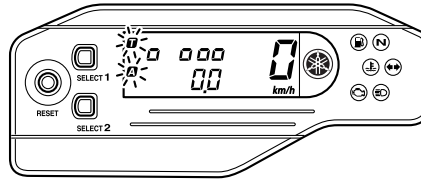

2. When the vehicle starts moving, the stopwatch will start counting.
3. Push the “SELECT 1” button and “SELECT 2” button together to stop the stopwatch.
4. To resume counting, push the “SELECT 1” button and “SELECT 2” button together again.

**NOTE:** \_\_\_\_\_

The stopwatch will continue counting when the vehicle is stopped. To stop and/or resume counting, repeat steps 3 and 4.

**Measurement mode (for calibrating the distance-compensation tripmeter’s reading)**

The distance-compensation tripmeter

is a feature intended to provide a more accurate tripmeter reading for enduro riding. Calibrating this meter in accordance with the distances specified on the enduro course map will help familiarize the rider with the course. In addition, calibrating the meter may also be necessary when using tire, wheel, chain sprocket sizes, etc. other than specified. For further information concerning the use of this meter, please consult your nearby Yamaha dealer. Calibrate the distance-compensation tripmeter as follows.

To increase the reading, push the “SELECT 1” button. To decrease the reading, push the “SELECT 2” button. Pushing and holding either button will increase or decrease the reading continuously until the button is released.

**NOTE:** \_\_\_\_\_

Calibrating the reading of the distance-compensation tripmeter is possible regardless of the stopwatch operation.

# INSTRUMENT AND CONTROL FUNCTIONS

## Resetting the distance-compensation tripmeter or the distance-compensation tripmeter in combination with the stopwatch

### NOTE:

Resetting can be made only to the distance-compensation tripmeter or to the distance-compensation tripmeter in combination with the stopwatch.

### Resetting the distance-compensation tripmeter

1. Check that the stopwatch measurement is in operation.
2. Reset the distance-compensation tripmeter to zero by pushing the “RESET” button for at least two seconds.

### Resetting the distance-compensation tripmeter in combination with the stopwatch

1. Stop the stopwatch.
2. Reset the distance-compensation tripmeter and the stopwatch to zero by pushing the “RESET” button for at least two seconds.

## Self-diagnosis device

This model is equipped with a self-diagnosis device for various electrical circuits.

If any of those circuits are defective, the engine trouble warning light will come on, and then the display will indicate a two-digit error code.

If the display indicates any error codes, note the code number, and then have a Yamaha dealer check the vehicle.

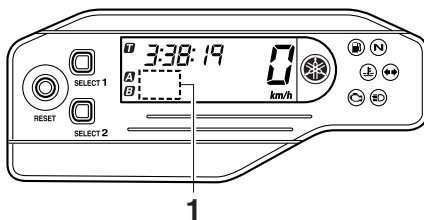

1. Error code display

ECA11590

### CAUTION:



**If the display indicates an error code, the vehicle should be checked as soon as possible in order to avoid engine damage.**

EAU12347

## Handlebar switches

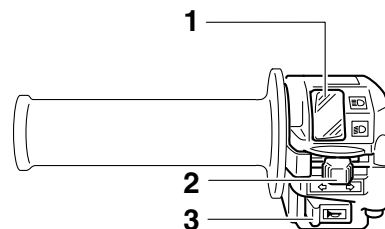
### Left



1. Dimmer switch “/”
2. Turn signal switch “/”
3. Horn switch “”

# INSTRUMENT AND CONTROL FUNCTIONS

## Right

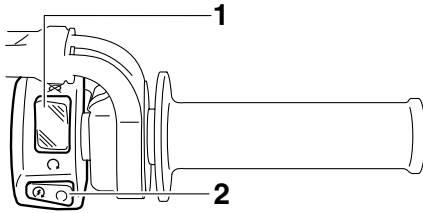

1. Engine stop switch “○/⊗”
2. Start switch “⊗”

## Dimmer switch “≡○/≡○”

EAU12400

Set this switch to “≡○” for the high beam and to “≡○” for the low beam.

## Turn signal switch “⇐/⇨”

EAU12460

To signal a right-hand turn, push this switch to “⇨”. To signal a left-hand turn, push this switch to “⇨”. When released, the switch returns to the center position. To cancel the turn signal lights, push the switch in after it has returned to the center position.

## Horn switch “📢”

EAU12500

Press this switch to sound the horn.

## Engine stop switch “○/⊗”

EAU12660

Set this switch to “○” before starting the engine. Set this switch to “⊗” to stop the engine in case of an emergency, such as when the vehicle overturns or when the throttle cable is stuck.

## Start switch “⊗”

EAU12710

Push this switch to crank the engine with the starter.

## CAUTION:

**See page 5-1 for starting instructions prior to starting the engine.**

ECA10050

EAU41700

The engine trouble warning light will come on when the key is turned to “ON” and the start switch is pushed, but this does not indicate a malfunction.

## Clutch lever

EAU12820

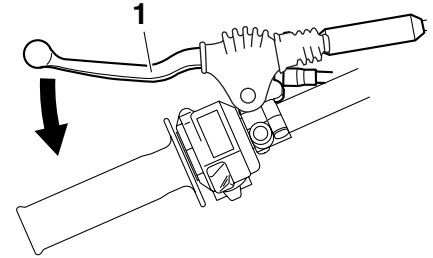

1. Clutch lever

The clutch lever is located at the left handlebar grip. To disengage the clutch, pull the lever toward the handlebar grip. To engage the clutch, release the lever. The lever should be pulled rapidly and released slowly for smooth clutch operation.

The clutch lever is equipped with a clutch switch, which is part of the ignition circuit cut-off system. (See page 3-18.)

# INSTRUMENT AND CONTROL FUNCTIONS

## Shift pedal

EAU12870

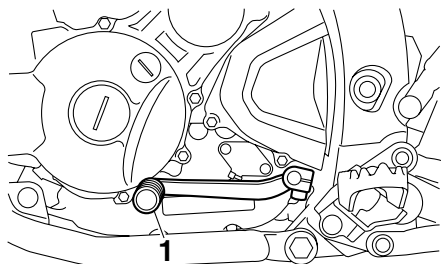

1. Shift pedal

The shift pedal is located on the left side of the engine and is used in combination with the clutch lever when shifting the gears of the 6-speed constant-mesh transmission equipped on this motorcycle.

## Brake lever

EAU12890

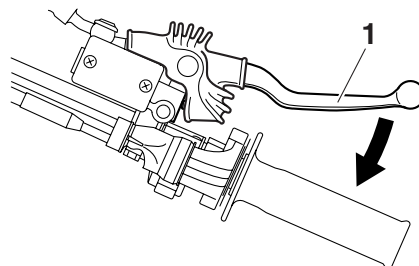

1. Brake lever

The brake lever is located at the right handlebar grip. To apply the front brake, pull the lever toward the handlebar grip.

## Brake pedal

EAU12941

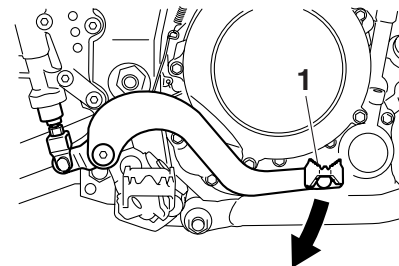

1. Brake pedal

The brake pedal is on the right side of the motorcycle. To apply the rear brake, press down on the brake pedal.



## Fuel tank cap

EAU44361

### To remove the fuel tank cap

1. Insert the key into the lock and turn it counterclockwise as shown.

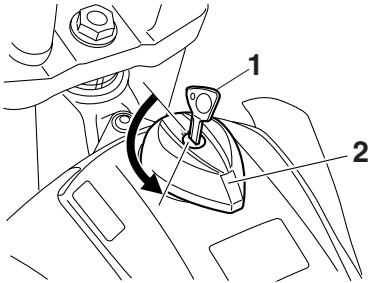

1. Key
2. Fuel tank cap

2. Turn the fuel tank cap counterclockwise and pull it off.

### To install the fuel tank cap

1. Insert the fuel tank cap into the tank opening with the key inserted in the lock, and then turn the cap clockwise.

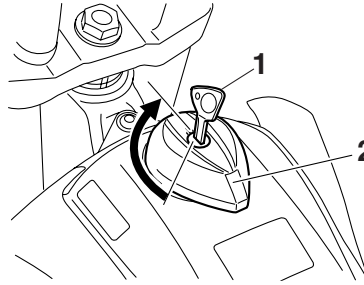

1. Key
2. Fuel tank cap

2. Turn the key clockwise, and then remove it.

### NOTE:

The fuel tank cap cannot be installed unless the key is in the lock. In addition, the key cannot be removed if the cap is not properly installed and locked.

EWA10120



**Make sure that the fuel tank cap is properly closed and locked before riding.**

## Fuel

EAU13211

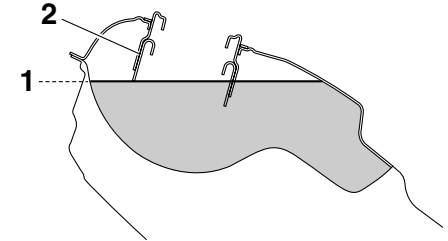

1. Fuel level
2. Fuel tank filler tube

Make sure that there is sufficient fuel in the tank. Fill the fuel tank to the bottom of the filler tube as shown.

EWA10880



- Do not overfill the fuel tank, otherwise it may overflow when the fuel warms up and expands.
- Avoid spilling fuel on the hot engine.

ECA10070

### CAUTION:

Immediately wipe off spilled fuel with a clean, dry, soft cloth, since

# INSTRUMENT AND CONTROL FUNCTIONS

fuel may deteriorate painted surfaces or plastic parts.

EAU13390

**Recommended fuel:**  
PREMIUM UNLEADED GASOLINE ONLY

**Fuel tank capacity:**  
7.6 L (2.01 US gal) (1.67 Imp.gal)

**Fuel reserve amount (when the fuel level warning light comes on):**  
2.1 L (0.55 US gal) (0.46 Imp.gal)

ECA11400

## CAUTION:

Use only unleaded gasoline. The use of leaded gasoline will cause severe damage to internal engine parts, such as the valves and piston rings, as well as to the exhaust system.

Your Yamaha engine has been designed to use premium unleaded gasoline with a research octane number of 95 or higher. If knocking (or pinging) occurs, use a gasoline of a different brand. Use of unleaded fuel will extend spark plug life and reduce maintenance costs.

## Catalytic converter

This model is equipped with a catalytic converter in the exhaust system.

EAU13431

EWA10860

## WARNING

The exhaust system is hot after operation. Make sure that the exhaust system has cooled down before doing any maintenance work.

ECA10700

## CAUTION:

The following precautions must be observed to prevent a fire hazard or other damages.

- Use only unleaded gasoline. The use of leaded gasoline will cause unreparable damage to the catalytic converter.
- Never park the vehicle near possible fire hazards such as grass or other materials that easily burn.
- Do not allow the engine to idle too long.

## Seat

EAU13970

### To remove the seat

Remove the bolts, and then pull the seat off.

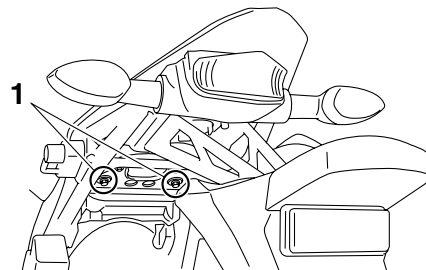

1. Bolt

### To install the seat

1. Insert the projection on the front of the seat into the seat holder as shown.

# INSTRUMENT AND CONTROL FUNCTIONS

EAU14281

EAU5200

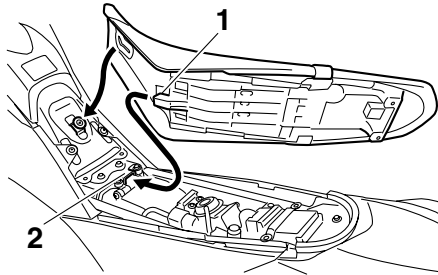

1. Projection
2. Seat holder

2. Place the seat in the original position, and then tighten the bolts.

## NOTE:

Make sure that the seat is properly secured before riding.

## Helmet holder

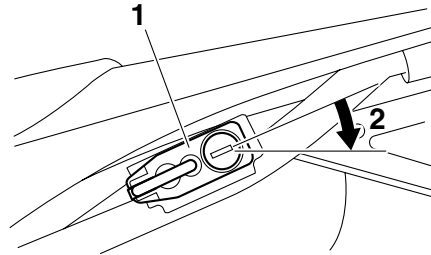

1. Helmet holder
2. Open.

To open the helmet holder, insert the key into the lock, and then turn the key as shown.

To lock the helmet holder, place it in the original position, and then remove the key.

EWA10160

## ! WARNING

**Never ride with a helmet attached to the helmet holder, since the helmet may hit objects, causing loss of control and possibly an accident.**

## Adjusting the front fork

This front fork is equipped with rebound damping force adjusting screws and compression damping force adjusting screws.

EWA10180

## ! WARNING

**Always adjust both fork legs equally, otherwise poor handling and loss of stability may result.**

3

## Rebound damping force

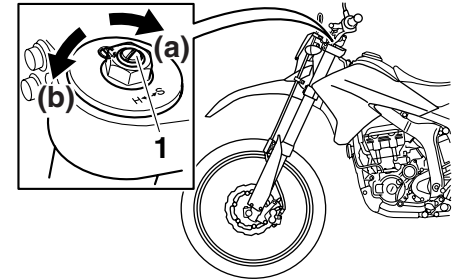

1. Rebound damping force adjusting screw

To increase the rebound damping force and thereby harden the rebound damping, turn the adjusting screw on each fork leg in direction (a). To decrease the

# INSTRUMENT AND CONTROL FUNCTIONS

rebound damping force and thereby soften the rebound damping, turn the adjusting screw on each fork leg in direction (b).

## Rebound damping setting:

Minimum (soft):

24 click(s) in direction (b)\*

Standard:

10 click(s) in direction (b)\*

Maximum (hard):

1 click(s) in direction (b)\*

\* With the adjusting screw fully turned in direction (a)

## Compression damping force

1. Remove the rubber cap by pulling it out of the front fork leg.

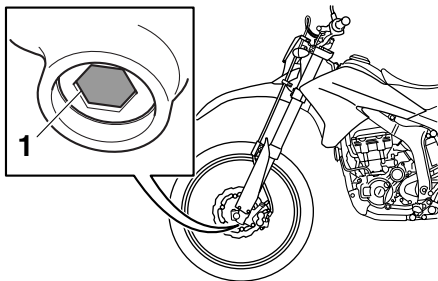

1. Rubber cap

2. To increase the compression damping force and thereby harden the compression damping, turn the adjusting screw on each fork leg in direction (a). To decrease the compression damping force and thereby soften the compression damping, turn the adjusting screw on each fork leg in direction (b).

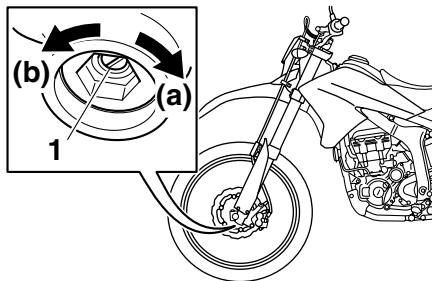

1. Compression damping force adjusting screw

## Compression damping setting:

Minimum (soft):

20 click(s) in direction (b)\*

Standard:

10 click(s) in direction (b)\*

Maximum (hard):

1 click(s) in direction (b)\*

\* With the adjusting screw fully turned in direction (a)

3. Install the rubber cap.

ECA10100

## CAUTION:

**Never attempt to turn an adjusting mechanism beyond the maximum or minimum settings.**

## NOTE:

Although the total number of clicks of a damping force adjusting mechanism may not exactly match the above specifications due to small differences in production, the actual number of clicks always represents the entire adjusting range. To obtain a precise adjustment, it would be advisable to check the number of clicks of each damping force adjusting mechanism and to modify the specifications as necessary.

# INSTRUMENT AND CONTROL FUNCTIONS

## Front fork bleeding

EAU14790

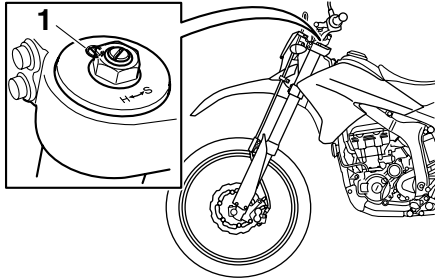

1. Bleed screw

When riding in extremely rough conditions, the air temperature and pressure in the front fork will rise. This will increase the spring preload and harden the front suspension. If this occurs, bleed the front fork as follows.

1. Elevate the front wheel by placing a suitable stand under the engine.

### NOTE: \_\_\_\_\_

When bleeding the front fork, there should be no weight on the front end of the vehicle.

2. Remove the bleed screws and allow all of the air to escape from

each fork leg.

### **!** WARNING \_\_\_\_\_

**Always bleed both fork legs, otherwise poor handling and loss of stability may result.**

3. Install the bleed screws.

EWA10200

## Adjusting the shock absorber assembly

EAU45260

This shock absorber assembly is equipped with a spring preload adjusting ring, a rebound damping force adjusting dial and a compression damping force adjusting screw.

ECA10100

### **CAUTION:** \_\_\_\_\_

**Never attempt to turn an adjusting mechanism beyond the maximum or minimum settings.**

### Spring preload

Spring preload adjustment should be made by a Yamaha dealer, since this service requires special tools and technical skills. The specified settings are listed below.

### NOTE: \_\_\_\_\_

The spring preload setting is determined by measuring distance A, shown in the illustration. The shorter the distance A is, the higher the spring preload; the longer distance A is, the lower the spring preload.

# INSTRUMENT AND CONTROL FUNCTIONS

3

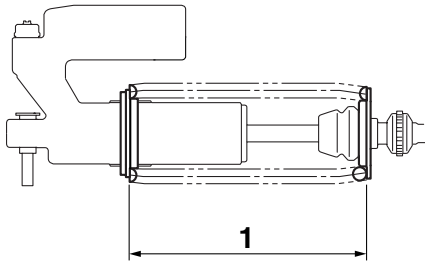

1. Distance A

## Spring preload:

Minimum (soft):

Distance A = 216 mm (8.50 in)

Standard:

Distance A = 211.5 mm (8.33 in)

Maximum (hard):

Distance A = 206 mm (8.11 in)

## Rebound damping force

To increase the rebound damping force and thereby harden the rebound damping, turn the adjusting dial in direction (a). To decrease the rebound damping force and thereby soften the rebound damping, turn the adjusting dial in direction (b).

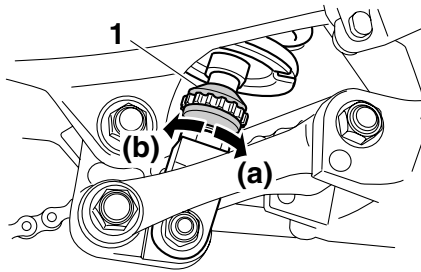

1. Rebound damping force adjusting dial

## Rebound damping setting:

Minimum (soft):

25 click(s) in direction (b)\*

Standard:

12 click(s) in direction (b)\*

Maximum (hard):

3 click(s) in direction (b)\*

\* With the adjusting dial fully turned in direction (a)

## Compression damping force

To increase the compression damping force and thereby harden the compression damping, turn the adjusting screw in direction (a). To decrease the compression damping force and thereby soften the compression damping, turn

the adjusting screw in direction (b).

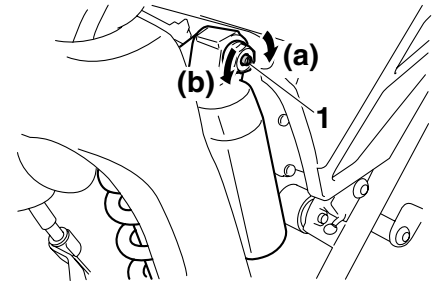

1. Compression damping force adjusting screw

## Compression damping setting:

Minimum (soft):

12 click(s) in direction (b)\*

Standard:

10 click(s) in direction (b)\*

Maximum (hard):

1 click(s) in direction (b)\*

\* With the adjusting screw fully turned in direction (a)

## NOTE:

Although the total number of clicks of a damping force adjusting mechanism may not exactly match the above specifications due to small differences in production, the actual number of clicks

# INSTRUMENT AND CONTROL FUNCTIONS

always represents the entire adjusting range. To obtain a precise adjustment, it would be advisable to check the number of clicks of each damping force adjusting mechanism and to modify the specifications as necessary.

EWA10220

## **WARNING**

**This shock absorber contains highly pressurized nitrogen gas. For proper handling, read and understand the following information before handling the shock absorber. The manufacturer cannot be held responsible for property damage or personal injury that may result from improper handling.**

- Do not tamper with or attempt to open the gas cylinder.
- Do not subject the shock absorber to an open flame or other high heat sources, otherwise it may explode due to excessive gas pressure.
- Do not deform or damage the gas cylinder in any way, as this will result in poor damping per-

formance.

- **Always have a Yamaha dealer service the shock absorber.**

EAU41940

## **EXUP system**

This model is equipped with Yamaha's EXUP (EXhaust Ultimate Power valve) system. This system boosts engine power by means of a valve that regulates the diameter of the exhaust pipe. The EXUP system valve is constantly adjusted in accordance with the engine speed by a computer-controlled servomotor.

ECA15610

## **CAUTION:**

**The EXUP system has been set and extensively tested at the Yamaha factory. Changing these settings without sufficient technical knowledge may result in poor performance of or damage to the engine.**

# INSTRUMENT AND CONTROL FUNCTIONS

## Sidestand

EAU15301

The sidestand is located on the left side of the frame. Raise the sidestand or lower it with your foot while holding the vehicle upright.

### NOTE:

The built-in sidestand switch is part of the ignition circuit cut-off system, which cuts the ignition in certain situations. (See further down for an explanation of the ignition circuit cut-off system.)

EWA10240

### WARNING

**The vehicle must not be ridden with the sidestand down, or if the sidestand cannot be properly moved up (or does not stay up), otherwise the sidestand could contact the ground and distract the operator, resulting in a possible loss of control. Yamaha's ignition circuit cut-off system has been designed to assist the operator in fulfilling the responsibility of raising the sidestand before starting off. Therefore, check this system regularly as described below and have a Yamaha dealer re-**

**pair it if it does not function properly.**

EAU44890

## Ignition circuit cut-off system

The ignition circuit cut-off system (comprising the sidestand switch, clutch switch and neutral switch) has the following functions.

- It prevents starting when the transmission is in gear and the sidestand is up, but the clutch lever is not pulled.
- It prevents starting when the transmission is in gear and the clutch lever is pulled, but the sidestand is still down.
- It cuts the running engine when the transmission is in gear and the sidestand is moved down.

Periodically check the operation of the ignition circuit cut-off system according to the following procedure.

EWA10250

### WARNING

**If a malfunction is noted, have a Yamaha dealer check the system before riding.**



# INSTRUMENT AND CONTROL FUNCTIONS

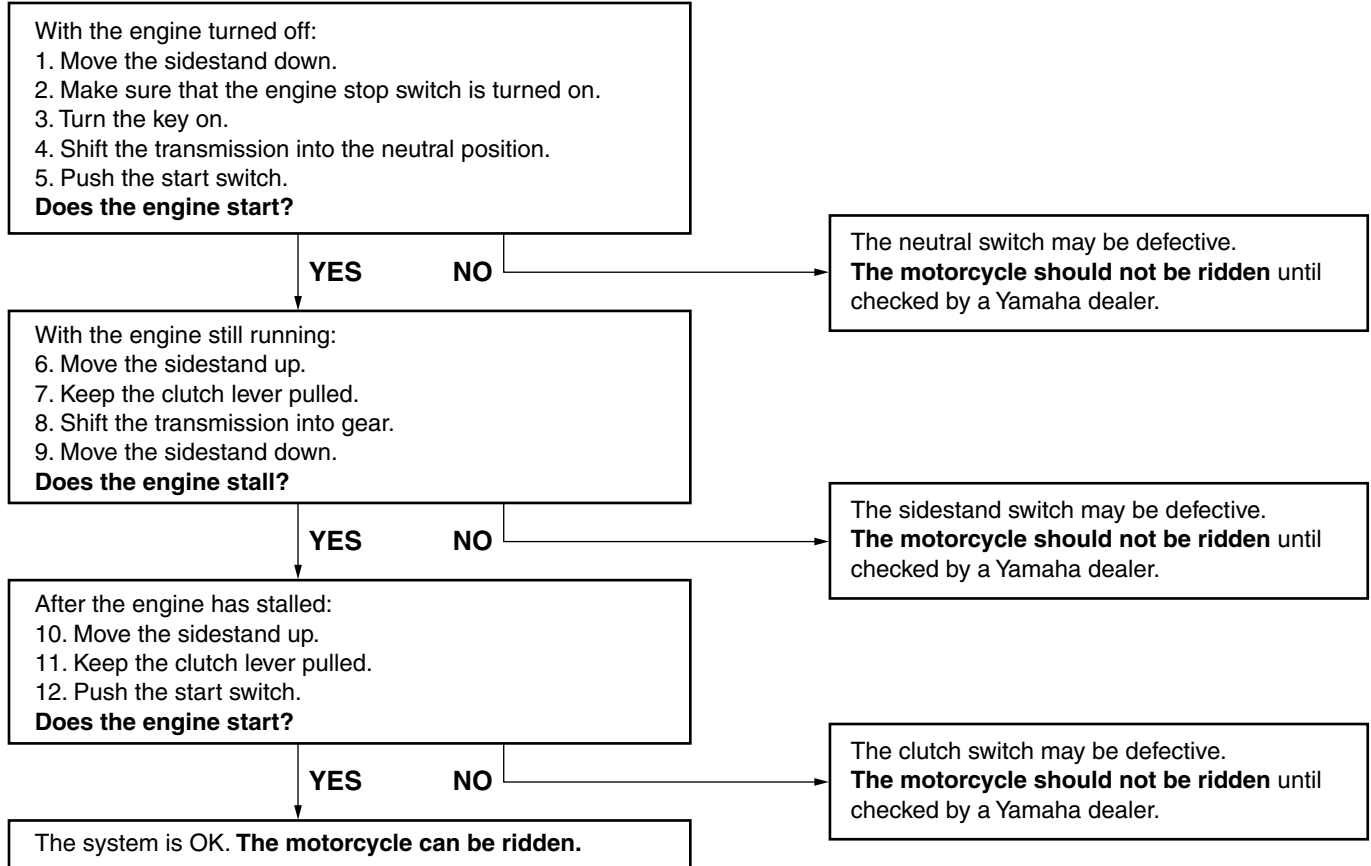

# PRE-OPERATION CHECKS

---

---

EAU15593

The condition of a vehicle is the owner's responsibility. Vital components can start to deteriorate quickly and unexpectedly, even if the vehicle remains unused (for example, as a result of exposure to the elements). Any damage, fluid leakage or loss of tire air pressure could have serious consequences. Therefore, it is very important, in addition to a thorough visual inspection, to check the following points before each ride.

**NOTE:** \_\_\_\_\_

Pre-operation checks should be made each time the vehicle is used. Such an inspection can be accomplished in a very short time; and the added safety it assures is more than worth the time involved.

---

EWA11150

** WARNING** \_\_\_\_\_

**If any item in the Pre-operation check list is not working properly, have it inspected and repaired before operating the vehicle.**

---

# PRE-OPERATION CHECKS

EAU15605

## Pre-operation check list

ITEM	CHECKS	PAGE
Fuel	<ul style="list-style-type: none"><li>• Check fuel level in fuel tank.</li><li>• Refuel if necessary.</li><li>• Check fuel line for leakage.</li></ul>	3-11
Engine oil	<ul style="list-style-type: none"><li>• Check oil level in engine.</li><li>• If necessary, add recommended oil to specified level.</li><li>• Check vehicle for oil leakage.</li></ul>	6-9
Coolant	<ul style="list-style-type: none"><li>• Check coolant level in reservoir.</li><li>• If necessary, add recommended coolant to specified level.</li><li>• Check cooling system for leakage.</li></ul>	6-12
Front brake	<ul style="list-style-type: none"><li>• Check operation.</li><li>• If soft or spongy, have Yamaha dealer bleed hydraulic system.</li><li>• Check lever free play.</li><li>• Adjust if necessary.</li><li>• Check brake pads for wear.</li><li>• Replace if necessary.</li><li>• Check fluid level in reservoir.</li><li>• If necessary, add recommended brake fluid to specified level.</li><li>• Check hydraulic system for leakage.</li></ul>	6-22, 6-23
Rear brake	<ul style="list-style-type: none"><li>• Check operation.</li><li>• If soft or spongy, have Yamaha dealer bleed hydraulic system.</li><li>• Check brake pads for wear.</li><li>• Replace if necessary.</li><li>• Check fluid level in reservoir.</li><li>• If necessary, add recommended brake fluid to specified level.</li><li>• Check hydraulic system for leakage.</li></ul>	6-23
Clutch	<ul style="list-style-type: none"><li>• Check operation.</li><li>• Lubricate cable if necessary.</li><li>• Check lever free play.</li><li>• Adjust if necessary.</li></ul>	6-21

# PRE-OPERATION CHECKS

ITEM	CHECKS	PAGE
<b>Throttle grip</b>	<ul style="list-style-type: none"> <li>• Make sure that operation is smooth.</li> <li>• Check cable free play.</li> <li>• If necessary, have Yamaha dealer adjust cable free play and lubricate cable and grip housing.</li> </ul>	6-18, 6-27
<b>Control cables</b>	<ul style="list-style-type: none"> <li>• Make sure that operation is smooth.</li> <li>• Lubricate if necessary.</li> </ul>	6-27
<b>Drive chain</b>	<ul style="list-style-type: none"> <li>• Check chain slack.</li> <li>• Adjust if necessary.</li> <li>• Check chain condition.</li> <li>• Lubricate if necessary.</li> </ul>	6-25, 6-26
<b>Wheels and tires</b>	<ul style="list-style-type: none"> <li>• Check for damage.</li> <li>• Check tire condition and tread depth.</li> <li>• Check air pressure.</li> <li>• Correct if necessary.</li> </ul>	6-18, 6-20
<b>Brake and shift pedals</b>	<ul style="list-style-type: none"> <li>• Make sure that operation is smooth.</li> <li>• Lubricate pedal pivoting points if necessary.</li> </ul>	6-27
<b>Brake and clutch levers</b>	<ul style="list-style-type: none"> <li>• Make sure that operation is smooth.</li> <li>• Lubricate lever pivoting points if necessary.</li> </ul>	6-28
<b>Sidestand</b>	<ul style="list-style-type: none"> <li>• Make sure that operation is smooth.</li> <li>• Lubricate pivot if necessary.</li> </ul>	6-29
<b>Chassis fasteners</b>	<ul style="list-style-type: none"> <li>• Make sure that all nuts, bolts and screws are properly tightened.</li> <li>• Tighten if necessary.</li> </ul>	—
<b>Instruments, lights, signals and switches</b>	<ul style="list-style-type: none"> <li>• Check operation.</li> <li>• Correct if necessary.</li> </ul>	—
<b>Sidestand switch</b>	<ul style="list-style-type: none"> <li>• Check operation of ignition circuit cut-off system.</li> <li>• If system is defective, have Yamaha dealer check vehicle.</li> </ul>	3-18

# OPERATION AND IMPORTANT RIDING POINTS

EAU15950

EAU45310

EAU45120

EWA10270

## **WARNING**

- **Become thoroughly familiar with all operating controls and their functions before riding. Consult a Yamaha dealer regarding any control or function that you do not thoroughly understand.**
- **Never start the engine or operate it in a closed area for any length of time. Exhaust fumes are poisonous, and inhaling them can cause loss of consciousness and death within a short time. Always make sure that there is adequate ventilation.**
- **Before starting out, make sure that the sidestand is up. If the sidestand is not raised completely, it could contact the ground and distract the operator, resulting in a possible loss of control.**

## **NOTE:**

This model is equipped with a lean angle sensor to stop the engine in case of a turnover. To start the engine after a turnover, be sure to turn the main switch to “OFF” and then to “ON”. Failing to do so will prevent the engine from starting even though the engine will crank when pushing the start switch.

## **Starting the engine**

In order for the ignition circuit cut-off system to enable starting, one of the following conditions must be met:

- The transmission is in the neutral position.
- The transmission is in gear with the clutch lever pulled and the sidestand up.

EWA10290

## **WARNING**

- **Before starting the engine, check the function of the ignition circuit cut-off system according to the procedure described on page 3-18.**
- **Never ride with the sidestand down.**

1. Turn the key to “ON” and make sure that the engine stop switch is set to “○”.

ECA16130

## **CAUTION:**

The following warning lights should come on for a few seconds, then go off.

- **Fuel level warning light**

# OPERATION AND IMPORTANT RIDING POINTS

- Coolant temperature warning light

- Engine trouble warning light

If a warning light does not go off, see page 3-2 for the corresponding warning light circuit check.

2. Shift the transmission into the neutral position.

**NOTE:** \_\_\_\_\_

When the transmission is in the neutral position, the neutral indicator light should be on, otherwise have a Yamaha dealer check the electrical circuit.

3. Start the engine by pushing the start switch.

**NOTE:** \_\_\_\_\_

If the engine fails to start, release the start switch, wait a few seconds, and then try again. Each starting attempt should be as short as possible to preserve the battery. Do not crank the engine more than 10 seconds on any one attempt.

ECA11130

## CAUTION: \_\_\_\_\_

For maximum engine life, always warm the engine up before starting off. Never accelerate hard when the engine is cold!

EAU16671

## Shifting

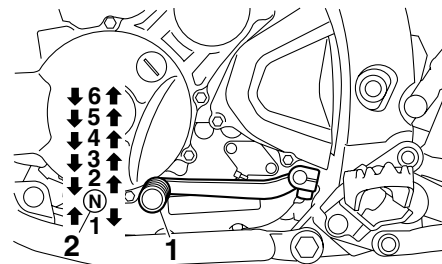

1. Shift pedal
2. Neutral position

Shifting gears lets you control the amount of engine power available for starting off, accelerating, climbing hills, etc.

The gear positions are shown in the illustration.

**NOTE:** \_\_\_\_\_

To shift the transmission into the neutral position, press the shift pedal down repeatedly until it reaches the end of its travel, and then slightly raise it.

ECA10260

## CAUTION: \_\_\_\_\_

- Even with the transmission in

# OPERATION AND IMPORTANT RIDING POINTS

the neutral position, do not coast for long periods of time with the engine off, and do not tow the motorcycle for long distances. The transmission is properly lubricated only when the engine is running. Inadequate lubrication may damage the transmission.

- Always use the clutch while changing gears to avoid damaging the engine, transmission, and drive train, which are not designed to withstand the shock of forced shifting.

EAU16810

## Tips for reducing fuel consumption

Fuel consumption depends largely on your riding style. Consider the following tips to reduce fuel consumption:

- Shift up swiftly, and avoid high engine speeds during acceleration.
- Do not rev the engine while shifting down, and avoid high engine speeds with no load on the engine.
- Turn the engine off instead of letting it idle for an extended length of time (e.g., in traffic jams, at traffic lights or at railroad crossings).

EAU16841

## Engine break-in

There is never a more important period in the life of your engine than the period between 0 and 1600 km (1000 mi). For this reason, you should read the following material carefully.

Since the engine is brand new, do not put an excessive load on it for the first 1600 km (1000 mi). The various parts in the engine wear and polish themselves to the correct operating clearances. During this period, prolonged full-throttle operation or any condition that might result in engine overheating must be avoided.

EAU17021

### 0–1000 km (0–600 mi)

Avoid prolonged operation above 1/3 throttle.

### 1000–1600 km (600–1000 mi)

Avoid prolonged operation above 1/2 throttle.

ECA11281

### CAUTION:

After 1000 km (600 mi) of operation,

# OPERATION AND IMPORTANT RIDING POINTS

---

the engine oil must be changed, and the oil filter cartridge or element replaced.

---

## 1600 km (1000 mi) and beyond

The vehicle can now be operated normally.

ECA10270

### CAUTION:

If any engine trouble should occur during the engine break-in period, immediately have a Yamaha dealer check the vehicle.

---

EAU17212

## Parking

When parking, stop the engine, and then remove the key from the main switch.

EWA10310

### WARNING

- Since the engine and exhaust system can become very hot, park in a place where pedestrians or children are not likely to touch them.
  - Do not park on a slope or on soft ground, otherwise the vehicle may overturn.
- 

ECA10380

### CAUTION:

Never park in an area where there are fire hazards such as grass or other flammable materials.

---



# PERIODIC MAINTENANCE AND MINOR REPAIR

EAU17240

EAU35010

EWA10350

Safety is an obligation of the owner. Periodic inspection, adjustment and lubrication will keep your vehicle in the safest and most efficient condition possible. The most important points of inspection, adjustment, and lubrication are explained on the following pages. The intervals given in the periodic maintenance and lubrication chart should be simply considered as a general guide under normal riding conditions. However, **DEPENDING ON THE WEATHER, TERRAIN, GEOGRAPHICAL LOCATION, AND INDIVIDUAL USE, THE MAINTENANCE INTERVALS MAY NEED TO BE SHORTENED.**

EWA10320

## **! WARNING**

**If you are not familiar with maintenance work, have a Yamaha dealer do it for you.**

## Owner's tool kit

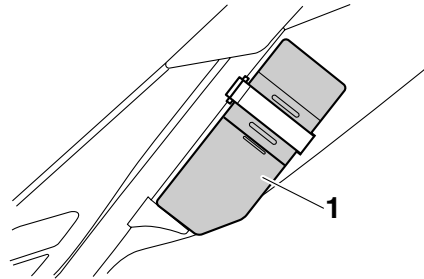

1. Tool box

The owner's tool kit is located inside the tool box.

The service information included in this manual and the tools provided in the owner's tool kit are intended to assist you in the performance of preventive maintenance and minor repairs. However, additional tools such as a torque wrench may be necessary to perform certain maintenance work correctly.

## **NOTE:**

If you do not have the tools or experience required for a particular job, have a Yamaha dealer perform it for you.

## **! WARNING**

**Modifications not approved by Yamaha may cause loss of performance and render the vehicle unsafe for use. Consult a Yamaha dealer before attempting any changes.**

# PERIODIC MAINTENANCE AND MINOR REPAIR

EAU1770A

## Periodic maintenance and lubrication chart

### NOTE:

- The annual checks must be performed every year, except if a kilometer-based maintenance, or for the UK, a mileage-based maintenance, is performed instead.
- From 50000 km (30000 mi), repeat the maintenance intervals starting from 10000 km (6000 mi).
- Items marked with an asterisk should be performed by a Yamaha dealer as they require special tools, data and technical skills.

NO.	ITEM	CHECK OR MAINTENANCE JOB	ODOMETER READING					ANNUAL CHECK
			1000 km (600 mi)	10000 km (6000 mi)	20000 km (12000 mi)	30000 km (18000 mi)	40000 km (24000 mi)	
1	* Fuel line	<ul style="list-style-type: none"> <li>● Check fuel hoses for cracks or damage.</li> </ul>		√	√	√	√	√
2	* Spark plug	<ul style="list-style-type: none"> <li>● Check condition.</li> <li>● Clean and regap.</li> </ul>		√		√		
		<ul style="list-style-type: none"> <li>● Replace.</li> </ul>			√		√	
3	* Valves	<ul style="list-style-type: none"> <li>● Check valve clearance.</li> <li>● Adjust.</li> </ul>	Every 40000 km (24000 mi)					
4	Air filter element	<ul style="list-style-type: none"> <li>● Clean.</li> </ul>		√		√		
		<ul style="list-style-type: none"> <li>● Replace.</li> </ul>			√		√	
5	Clutch	<ul style="list-style-type: none"> <li>● Check operation.</li> <li>● Adjust.</li> </ul>	√	√	√	√	√	
6	* Front brake	<ul style="list-style-type: none"> <li>● Check operation, fluid level and vehicle for fluid leakage.</li> <li>● Adjust brake lever free play.</li> </ul>	√	√	√	√	√	√
		<ul style="list-style-type: none"> <li>● Replace brake pads.</li> </ul>	Whenever worn to the limit					
7	* Rear brake	<ul style="list-style-type: none"> <li>● Check operation, fluid level and vehicle for fluid leakage.</li> </ul>	√	√	√	√	√	√
		<ul style="list-style-type: none"> <li>● Replace brake pads.</li> </ul>	Whenever worn to the limit					

# PERIODIC MAINTENANCE AND MINOR REPAIR

NO.	ITEM	CHECK OR MAINTENANCE JOB	ODOMETER READING					ANNUAL CHECK
			1000 km (600 mi)	10000 km (6000 mi)	20000 km (12000 mi)	30000 km (18000 mi)	40000 km (24000 mi)	
8	*	<b>Brake hoses</b>	<ul style="list-style-type: none"> <li>• Check for cracks or damage.</li> </ul>	√	√	√	√	√
			<ul style="list-style-type: none"> <li>• Replace.</li> </ul>	Every 4 years				
9	*	<b>Wheels</b>	<ul style="list-style-type: none"> <li>• Check runout, spoke tightness and for damage.</li> <li>• Tighten spokes if necessary.</li> </ul>	√	√	√	√	
10	*	<b>Tires</b>	<ul style="list-style-type: none"> <li>• Check tread depth and for damage.</li> <li>• Replace if necessary.</li> <li>• Check air pressure.</li> <li>• Correct if necessary.</li> </ul>	√	√	√	√	√
11	*	<b>Wheel bearings</b>	<ul style="list-style-type: none"> <li>• Check bearing for looseness or damage.</li> </ul>	√	√	√	√	
12	*	<b>Swingarm</b>	<ul style="list-style-type: none"> <li>• Check operation and for excessive play.</li> </ul>	√	√	√	√	
13		<b>Drive chain</b>	<ul style="list-style-type: none"> <li>• Check chain slack, alignment and condition.</li> <li>• Adjust and lubricate chain with a special O-ring chain lubricant thoroughly.</li> </ul>	Every 500 km (300 mi) and after washing the motorcycle or riding in the rain				
14	*	<b>Steering bearings</b>	<ul style="list-style-type: none"> <li>• Check bearing play and steering for roughness.</li> </ul>	√	√	√	√	√
			<ul style="list-style-type: none"> <li>• Lubricate with lithium-soap-based grease.</li> </ul>	Every 50000 km (30000 mi)				
15	*	<b>Chassis fasteners</b>	<ul style="list-style-type: none"> <li>• Make sure that all nuts, bolts and screws are properly tightened.</li> </ul>	√	√	√	√	√
16		<b>Brake lever pivot shaft</b>	<ul style="list-style-type: none"> <li>• Lubricate with silicone grease.</li> </ul>	√	√	√	√	√

# PERIODIC MAINTENANCE AND MINOR REPAIR

NO.	ITEM	CHECK OR MAINTENANCE JOB	ODOMETER READING					ANNUAL CHECK	
			1000 km (600 mi)	10000 km (6000 mi)	20000 km (12000 mi)	30000 km (18000 mi)	40000 km (24000 mi)		
17	<b>Brake pedal pivot shaft</b>	<ul style="list-style-type: none"> <li>Lubricate with lithium-soap-based grease.</li> </ul>		√	√	√	√	√	
18	<b>Clutch lever pivot shaft</b>	<ul style="list-style-type: none"> <li>Lubricate with lithium-soap-based grease.</li> </ul>		√	√	√	√	√	
19	<b>Shift pedal pivot shaft</b>	<ul style="list-style-type: none"> <li>Lubricate with lithium-soap-based grease.</li> </ul>		√	√	√	√	√	
20	<b>Sidestand</b>	<ul style="list-style-type: none"> <li>Check operation.</li> <li>Lubricate.</li> </ul>		√	√	√	√	√	
21 *	<b>Sidestand switch</b>	<ul style="list-style-type: none"> <li>Check operation.</li> </ul>	√	√	√	√	√	√	
22 *	<b>Front fork</b>	<ul style="list-style-type: none"> <li>Check operation and for oil leakage.</li> </ul>		√	√	√	√		
23 *	<b>Shock absorber assembly</b>	<ul style="list-style-type: none"> <li>Check operation and shock absorber for oil leakage.</li> </ul>		√	√	√	√		
24 *	<b>Rear suspension relay arm and connecting arm pivoting points</b>	<ul style="list-style-type: none"> <li>Check operation.</li> </ul>		√	√	√	√		
25	<b>Engine oil</b>	<ul style="list-style-type: none"> <li>Change.</li> <li>Check oil level and vehicle for oil leakage.</li> </ul>	√	Every 5000 km (3000 mi)					√
26	<b>Engine oil filter element</b>	<ul style="list-style-type: none"> <li>Replace.</li> </ul>	√	√	√	√	√		
27 *	<b>Cooling system</b>	<ul style="list-style-type: none"> <li>Check coolant level and vehicle for coolant leakage.</li> </ul>		√	√	√	√	√	
		<ul style="list-style-type: none"> <li>Change.</li> </ul>	Every 3 years						
28 *	<b>Front and rear brake switches</b>	<ul style="list-style-type: none"> <li>Check operation.</li> </ul>	√	√	√	√	√	√	
29	<b>Moving parts and cables</b>	<ul style="list-style-type: none"> <li>Lubricate.</li> </ul>		√	√	√	√	√	

# PERIODIC MAINTENANCE AND MINOR REPAIR

NO.	ITEM	CHECK OR MAINTENANCE JOB	ODOMETER READING					ANNUAL CHECK
			1000 km (600 mi)	10000 km (6000 mi)	20000 km (12000 mi)	30000 km (18000 mi)	40000 km (24000 mi)	
30	* Throttle grip housing and cable	<ul style="list-style-type: none"> <li>• Check operation and free play.</li> <li>• Adjust the throttle cable free play if necessary.</li> <li>• Lubricate the throttle grip housing and cable.</li> </ul>		√	√	√	√	√
31	* Air induction system	<ul style="list-style-type: none"> <li>• Check the air cut-off valve, reed valve, and hose for damage.</li> <li>• Replace any damaged parts if necessary.</li> </ul>		√	√	√	√	√
32	* EXUP system	<ul style="list-style-type: none"> <li>• Check operation, cable free play and pulley position.</li> </ul>	√		√		√	
33	* Lights, signals and switches	<ul style="list-style-type: none"> <li>• Check operation.</li> <li>• Adjust headlight beam.</li> </ul>	√	√	√	√	√	√

EAU18670

**NOTE:**

- The air filter needs more frequent service if you are riding in unusually wet or dusty areas.
- Hydraulic brake service
  - Regularly check and, if necessary, correct the brake fluid level.
  - Every two years replace the internal components of the brake master cylinders and calipers, and change the brake fluid.
  - Replace the brake hoses every four years and if cracked or damaged.

# PERIODIC MAINTENANCE AND MINOR REPAIR

EAU18771

## Removing and installing panels

The panels shown need to be removed to perform some of the maintenance jobs described in this chapter. Refer to this section each time a panel needs to be removed and installed.

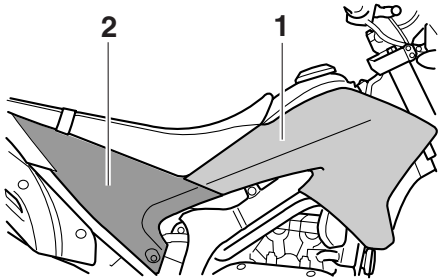

1. Panel A
2. Panel B

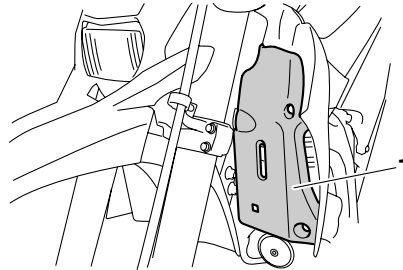

1. Panel C

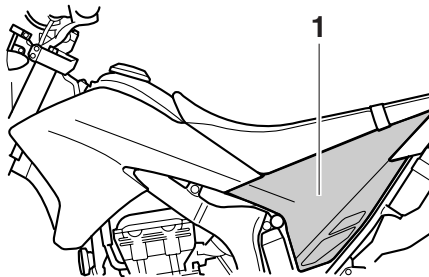

1. Panel D

EAU45131

## Panel A

### To remove the panel

1. Remove the seat. (See

6-6

page 3-12.)

2. Remove the bolts and collars.

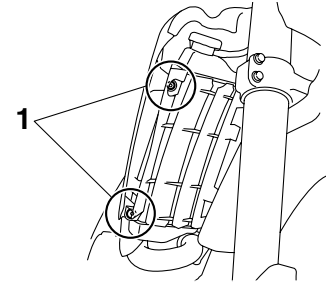

1. Bolt

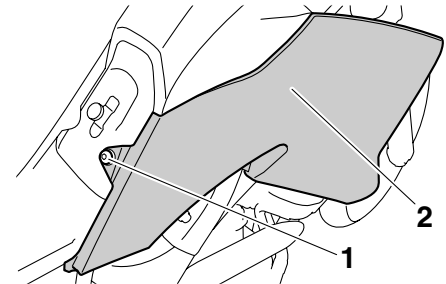

1. Bolt
2. Panel A

3. Pull the front part of the panel outward, and then remove the panel by pulling it off.

# PERIODIC MAINTENANCE AND MINOR REPAIR

## To install the panel

1. Place the panel in the original position, and then install the collars and bolts.

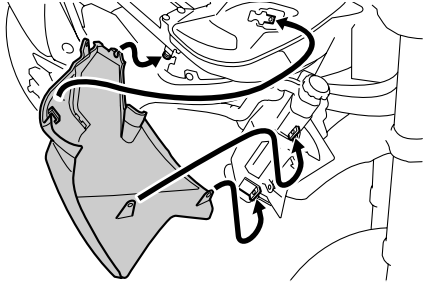

2. Install the seat.

## **Panel B**

### To remove the panel

1. Remove the seat. (See page 3-12.)
2. Remove the bolt, and then remove the panel as shown.

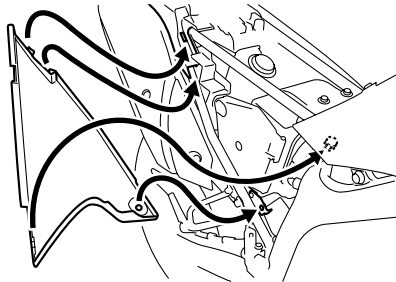

2. Install the seat.

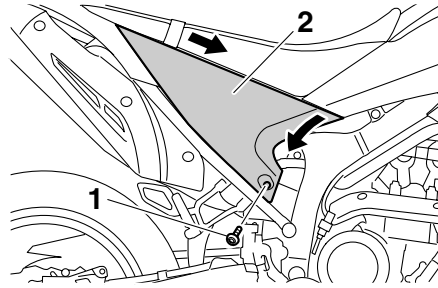

1. Bolt
2. Panel B

### To install the panel

1. Place the panel in the original position, and then install the bolt.

## **Panel C**

### To remove the panel

1. Remove the bolts.

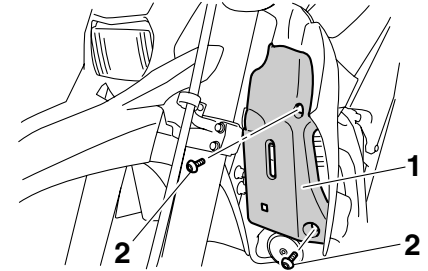

1. Panel C
2. Bolt

2. Lift the bottom of the panel slightly, and then slide the panel forward.

### To install the panel

Place the panel in the original position, and then install the bolts.

# PERIODIC MAINTENANCE AND MINOR REPAIR

EAU19621

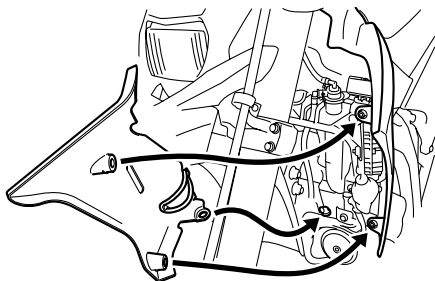

## Panel D

### To remove the panel

1. Remove the seat. (See page 3-12.)
2. Remove the bolt and washer, and then remove the panel as shown.

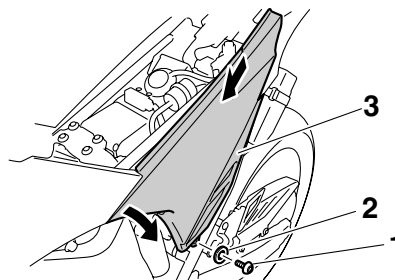

1. Bolt
2. Washer
3. Panel D

### To install the panel

1. Place the panel in the original position, and then install the washer and bolt.

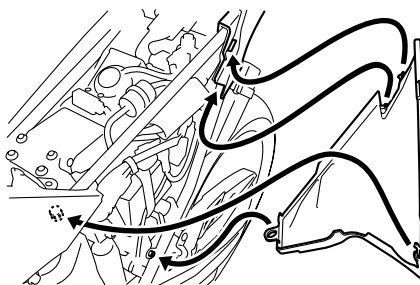

2. Install the seat.

## Checking the spark plug

The spark plug is an important engine component, which should be checked periodically, preferably by a Yamaha dealer. Since heat and deposits will cause any spark plug to slowly erode, it should be removed and checked in accordance with the periodic maintenance and lubrication chart. In addition, the condition of the spark plug can reveal the condition of the engine.

The porcelain insulator around the center electrode of the spark plug should be a medium-to-light tan (the ideal color when the vehicle is ridden normally). If the spark plug shows a distinctly different color, the engine could be operating improperly. Do not attempt to diagnose such problems yourself. Instead, have a Yamaha dealer check the vehicle. If the spark plug shows signs of electrode erosion and excessive carbon or other deposits, it should be replaced.

**Specified spark plug:**  
NGK/CR9EK

Before installing a spark plug, the spark



# PERIODIC MAINTENANCE AND MINOR REPAIR

EAU45140

plug gap should be measured with a wire thickness gauge and, if necessary, adjusted to specification.

of the correct torque is 1/4–1/2 turn past finger tight. However, the spark plug should be tightened to the specified torque as soon as possible.

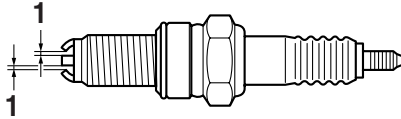

1. Spark plug gap

## Spark plug gap:

0.6–0.7 mm (0.024–0.028 in)

Clean the surface of the spark plug gasket and its mating surface, and then wipe off any grime from the spark plug threads.

## Tightening torque:

Spark plug:

13 Nm (1.3 m·kgf, 9.4 ft·lbf)

## NOTE:

If a torque wrench is not available when installing a spark plug, a good estimate

## Engine oil and oil filter element

The engine oil level should be checked before each ride. In addition, the oil must be changed and the oil filter element replaced at the intervals specified in the periodic maintenance and lubrication chart.

### To check the engine oil level

1. Place the vehicle on a level surface and hold it in an upright position.

## NOTE:

Make sure that the vehicle is positioned straight up when checking the oil level. A slight tilt to the side can result in a false reading.

2. Start the engine, warm it up for several minutes, and then turn it off.
3. Wait a few minutes until the oil settles, and then check the oil level through the check window located at the bottom-right side of the crankcase.

# PERIODIC MAINTENANCE AND MINOR REPAIR

## NOTE:

The engine oil should be between the minimum and maximum level marks.

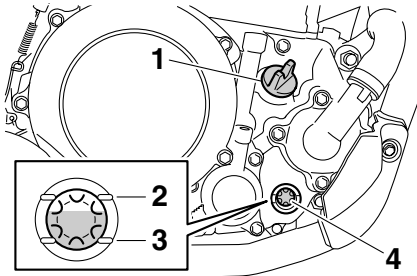

1. Engine oil filler cap
2. Maximum level mark
3. Minimum level mark
4. Engine oil level check window

4. If the engine oil is below the minimum level mark, add sufficient oil of the recommended type to raise it to the correct level.

## To change the engine oil (with or without oil filter element replacement)

1. Place the vehicle on a level surface.

2. Start the engine, warm it up for several minutes, and then turn it off.
3. Place an oil pan under the engine to collect the used oil.
4. Remove the engine oil filler cap and drain bolt to drain the oil from the crankcase.

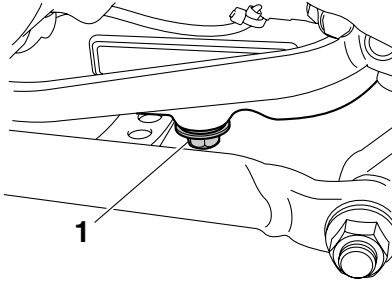

1. Engine oil drain bolt

## NOTE:

Check the washer for damage and replace it if necessary.

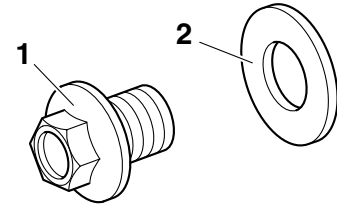

1. Engine oil drain bolt
2. Washer

## NOTE:

Skip steps 5–7 if the oil filter element is not being replaced.

5. Remove the oil filter element cover by removing the bolts.

# PERIODIC MAINTENANCE AND MINOR REPAIR

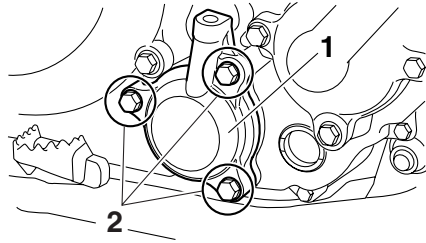

1. Oil filter element cover
2. Oil filter element cover bolt

6. Remove and replace the oil filter element and O-rings.

**NOTE:** \_\_\_\_\_  
Make sure that the O-rings are properly seated.

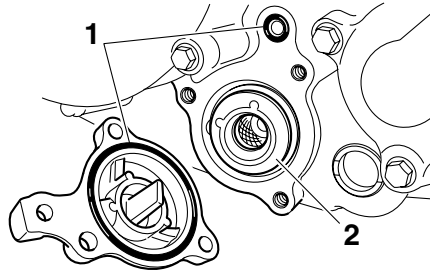

1. O-ring
2. Oil filter element

7. Install the oil filter element cover by installing the bolts, then tightening them to the specified torque.

**Tightening torque:**  
Oil filter element cover bolt:  
10 Nm (1.0 m·kgf, 7.2 ft·lbf)

8. Install the engine oil drain bolt, and then tighten it to the specified torque.

**Tightening torque:**  
Engine oil drain bolt:  
20 Nm (2.0 m·kgf, 14.5 ft·lbf)

9. Add the specified amount of the recommended engine oil, and then

install and tighten the oil filler cap.

## Recommended oil:

See page 8-1.

## Oil quantity:

Without oil filter element replacement:

1.30 L (1.37 US qt) (1.14 Imp.qt)

With oil filter element replacement:

1.40 L (1.48 US qt) (1.23 Imp.qt)

## NOTE: \_\_\_\_\_

Be sure to wipe off spilled oil on any parts after the engine and exhaust system have cooled down.

ECA11620

## CAUTION: \_\_\_\_\_

- In order to prevent clutch slippage (since the engine oil also lubricates the clutch), do not mix any chemical additives. Do not use oils with a diesel specification of “CD” or oils of a higher quality than specified. In addition, do not use oils labeled “ENERGY CONSERVING II” or higher.
- Make sure that no foreign material enters the crankcase.

# PERIODIC MAINTENANCE AND MINOR REPAIR

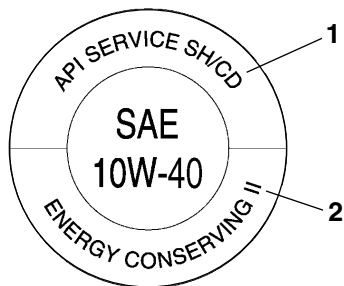

1. "CD" specification
2. "ENERGY CONSERVING II"

10. Start the engine, and then let it idle for several minutes while checking it for oil leakage. If oil is leaking, immediately turn the engine off and check for the cause.
11. Turn the engine off, and then check the oil level and correct it if necessary.

ECA11230

## CAUTION:

After changing the engine oil, make sure to check the oil pressure as described below.

- Remove the bleed bolt.
- Start the engine and keep it idling until oil flows out. If no oil

comes out after one minute, turn the engine off immediately so it will not seize. If this occurs, have a Yamaha dealer repair the vehicle.

- After checking the oil pressure, tighten the bleed bolt to the specified torque.

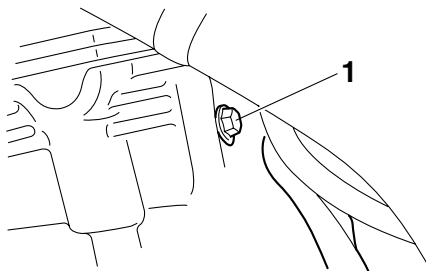

1. Bleed bolt

### Tightening torque:

Bleed bolt:  
10 Nm (1.0 m·kgf, 7.2 ft·lbf)

EAU20070

## Coolant

The coolant level should be checked before each ride. In addition, the coolant must be changed at the intervals specified in the periodic maintenance and lubrication chart.

EAU20252

### To check the coolant level

1. Place the vehicle on a level surface and hold it in an upright position.

### NOTE:

- The coolant level must be checked on a cold engine since the level varies with engine temperature.
- Make sure that the vehicle is positioned straight up when checking the coolant level. A slight tilt to the side can result in a false reading.

2. Check the coolant level in the coolant reservoir.

### NOTE:

The coolant should be between the minimum and maximum level marks.

# PERIODIC MAINTENANCE AND MINOR REPAIR

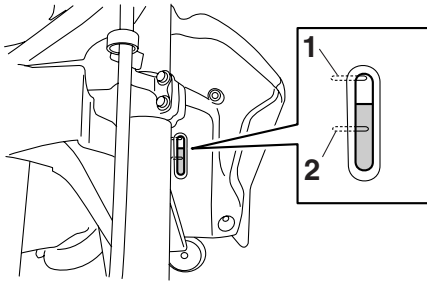

1. Maximum level mark
2. Minimum level mark

3. If the coolant is at or below the minimum level mark, remove panel C (See page 6-6.), remove the reservoir cap, add coolant to the maximum level mark, and then install the reservoir cap and the panel.

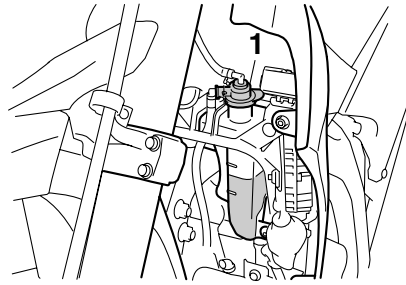

1. Coolant reservoir cap

**Coolant reservoir capacity (up to the maximum level mark):**  
0.25 L (0.26 US qt) (0.22 Imp.qt)

ECA10471

## CAUTION:

- If coolant is not available, use distilled water or soft tap water instead. Do not use hard water or salt water since it is harmful to the engine.
- If water has been used instead of coolant, replace it with coolant as soon as possible, otherwise the cooling system will not be protected against frost and corrosion.
- If water has been added to the

coolant, have a Yamaha dealer check the antifreeze content of the coolant as soon as possible, otherwise the effectiveness of the coolant will be reduced.

EWA10380

## ⚠ WARNING

Never attempt to remove the radiator cap when the engine is hot.

## NOTE:

- The radiator fan is automatically switched on or off according to the coolant temperature in the radiator.
- If the engine overheats, see page 6-41 for further instructions.

EAU45152

## To change the coolant

1. Place the vehicle on a level surface and let the engine cool if necessary.
2. Place a container under the engine to collect the used coolant.
3. Remove the radiator cap retaining bolt and radiator cap.

# PERIODIC MAINTENANCE AND MINOR REPAIR

EWA10380

## **WARNING**

Never attempt to remove the radiator cap when the engine is hot.

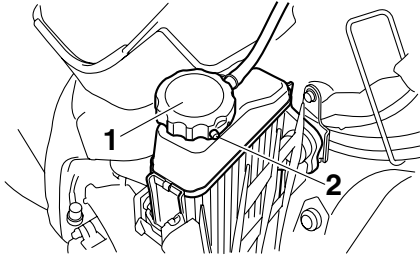

1. Radiator cap
2. Radiator cap retaining bolt

4. Remove the coolant reservoir by removing the bolts.

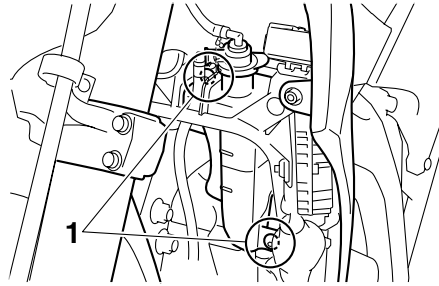

1. Bolt

5. Remove the coolant reservoir cap.

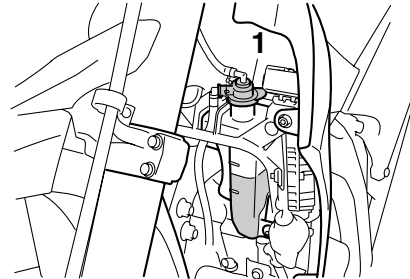

1. Coolant reservoir cap

6. Drain the coolant from the coolant reservoir by turning it upside down.
7. Install the coolant reservoir by placing it in the original position, and then installing the bolts.

8. Remove the coolant drain bolt to drain the cooling system.

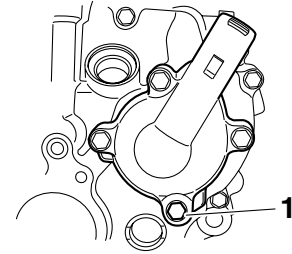

1. Coolant drain bolt

9. After the coolant is completely drained, thoroughly flush the cooling system with clean tap water.
10. Install the coolant drain bolt, and then tighten it to the specified torque.

### **NOTE:**

Check the washer for damage and replace it if necessary.

### **Tightening torque:**

Coolant drain bolt:  
10 Nm (1.0 m·kgf, 7.2 ft·lbf)

11. Pour the specified amount of the

# PERIODIC MAINTENANCE AND MINOR REPAIR

recommended coolant into the radiator and reservoir.

**Antifreeze/water mixture ratio:**  
1:1

**Recommended antifreeze:**

High-quality ethylene glycol antifreeze containing corrosion inhibitors for aluminum engines

**Coolant quantity:**

Radiator capacity (including all routes):

0.90 L (0.95 US qt) (0.79 Imp.qt)

Coolant reservoir capacity (up to the maximum level mark):

0.25 L (0.26 US qt) (0.22 Imp.qt)

ECA10471

## CAUTION:

- If coolant is not available, use distilled water or soft tap water instead. Do not use hard water or salt water since it is harmful to the engine.
- If water has been used instead of coolant, replace it with coolant as soon as possible, otherwise the cooling system will not be protected against frost and corrosion.
- If water has been added to the

coolant, have a Yamaha dealer check the antifreeze content of the coolant as soon as possible, otherwise the effectiveness of the coolant will be reduced.

12. Install the coolant reservoir cap.
13. Install the radiator cap.
14. Start the engine, let it idle for several minutes, and then turn it off.
15. Remove the radiator cap to check the coolant level in the radiator. If necessary, add sufficient coolant until it reaches the top of the radiator, and then install the radiator cap and its retaining bolt.
16. Check the coolant level in the reservoir. If necessary, remove the coolant reservoir cap, add coolant to the maximum level mark, and then install the cap.
17. Start the engine, and then check the vehicle for coolant leakage. If coolant is leaking, have a Yamaha dealer check the cooling system.

EAU44321

## Cleaning the air filter element and check hose

The air filter element should be cleaned at the intervals specified in the periodic maintenance and lubrication chart. Clean the air filter element more frequently if you are riding in unusually wet or dusty areas. In addition, the air filter check hose must be frequently checked and cleaned if necessary.

### To clean the air filter element

1. Remove panel B. (See page 6-6.)
2. Open the air filter case cover by removing the screw and pulling the case cover outward as shown.

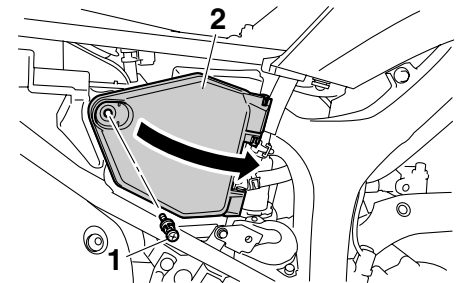

1. Screw
2. Air filter case cover

# PERIODIC MAINTENANCE AND MINOR REPAIR

3. Unhook the holding clip, and then pull the air filter element out.

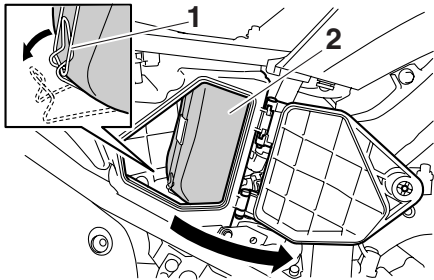

- 1. Holding clip
- 2. Air filter element

4. Remove the sponge material from the air filter element frame, clean it with solvent, and then squeeze the remaining solvent out.

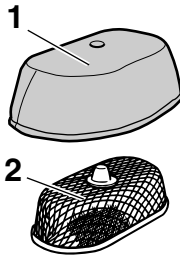

- 1. Sponge material
- 2. Air filter element frame

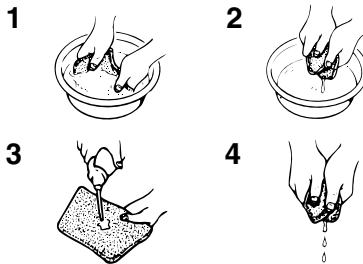

5. Apply oil of the recommended type to the entire surface of the sponge material, and then squeeze the excess oil out.

**NOTE:** \_\_\_\_\_  
The sponge material should be wet but

not dripping.

## Recommended oil:

Yamaha foam air filter oil or other quality foam air filter oil

- 6. Pull the sponge material over the air filter element frame.
- 7. Insert the air filter element into the air filter case.

ECA10480

## CAUTION:

- Make sure that the air filter element is properly seated in the air filter case.
- The engine should never be operated without the air filter element installed, otherwise the piston(s) and/or cylinder(s) may become excessively worn.

- 8. Place the holding clip in the original position.
- 9. Close the air filter case cover, and then install the screw.
- 10. Install the panel.

## To clean the air filter check hose

- 1. Check the hose at the bottom of



# PERIODIC MAINTENANCE AND MINOR REPAIR

the air filter case for accumulated dirt or water.

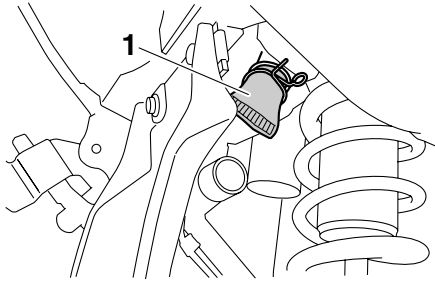

1. Air filter check hose
2. If dirt or water is visible, remove the hose, clean it, and then install it.

EAU45321

## Adjusting the engine idling speed

The engine idling speed must be checked and, if necessary, adjusted as follows.

### NOTE:

A diagnostic tachometer is needed to make this adjustment.

1. Attach the tachometer to the spark plug lead.
2. Check the engine idling speed and, if necessary, adjust it to specification by turning the idle adjusting screw. To increase the engine idling speed, turn the screw in direction (a). To decrease the engine idling speed, turn the screw in direction (b).

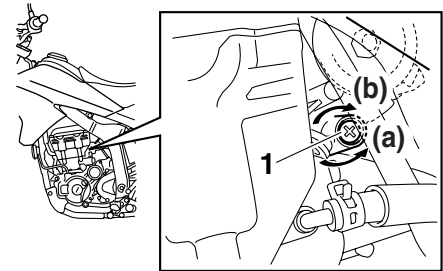

1. Idle adjusting screw

**Engine idling speed:**  
1450–1650 r/min

### NOTE:

If the specified idling speed cannot be obtained as described above, have a Yamaha dealer make the adjustment.

# PERIODIC MAINTENANCE AND MINOR REPAIR

EAU21382

## Checking the throttle cable free play

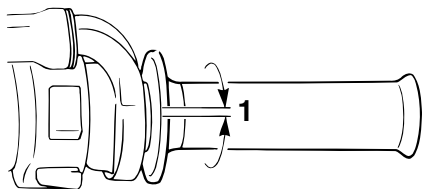

### 1. Throttle cable free play

The throttle cable free play should measure 3.0–5.0 mm (0.12–0.20 in) at the throttle grip. Periodically check the throttle cable free play and, if necessary, have a Yamaha dealer adjust it.

6

EAU21401

## Valve clearance

The valve clearance changes with use, resulting in improper air-fuel mixture and/or engine noise. To prevent this from occurring, the valve clearance must be adjusted by a Yamaha dealer at the intervals specified in the periodic maintenance and lubrication chart.

EAU21640

## Tires

To maximize the performance, durability, and safe operation of your motorcycle, note the following points regarding the specified tires.

### Tire air pressure

The tire air pressure should be checked and, if necessary, adjusted before each ride.

EWA10500

### WARNING

- The tire air pressure must be checked and adjusted on cold tires (i.e., when the temperature of the tires equals the ambient temperature).
- The tire air pressure must be adjusted in accordance with the riding speed and with the total weight of rider, passenger, cargo, and accessories approved for this model.

# PERIODIC MAINTENANCE AND MINOR REPAIR

**Tire air pressure (measured on cold tires):**

**0–90 kg (0–198 lb):**

Front:

125 kPa (18 psi) (1.25 kgf/cm<sup>2</sup>)

Rear:

175 kPa (25 psi) (1.75 kgf/cm<sup>2</sup>)

**90–185 kg (198–408 lb):**

Front:

150 kPa (22 psi) (1.50 kgf/cm<sup>2</sup>)

Rear:

200 kPa (29 psi) (2.00 kgf/cm<sup>2</sup>)

**Maximum load\*:**

185 kg (408 lb)

\* Total weight of rider, passenger, cargo and accessories

EWA11020

## **WARNING**

Because loading has an enormous impact on the handling, braking, performance and safety characteristics of your motorcycle, you should keep the following precautions in mind.

- **NEVER OVERLOAD THE MOTORCYCLE!** Operation of an overloaded motorcycle may result in tire damage, loss of control, or severe injury. Make sure that the total weight of rider,

passenger, cargo, and accessories does not exceed the specified maximum load for the vehicle.

- **Do not carry along loosely packed items, which can shift during a ride.**
- **Securely pack the heaviest items close to the center of the motorcycle and distribute the weight evenly on both sides.**
- **Adjust the suspension and tire air pressure with regard to the load.**
- **Check the tire condition and air pressure before each ride.**

## Tire inspection

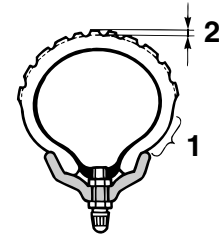

1. Tire sidewall
2. Tire tread depth

The tires must be checked before each ride. If the center tread depth reaches the specified limit, if the tire has a nail or glass fragments in it, or if the sidewall is cracked, have a Yamaha dealer replace the tire immediately.

**Minimum tire tread depth (front and rear):**

1.6 mm (0.06 in)

**NOTE:** \_\_\_\_\_

The tire tread depth limits may differ from country to country. Always comply with the local regulations.

# PERIODIC MAINTENANCE AND MINOR REPAIR

EAU21940

## Tire information

This motorcycle is equipped with tube tires.

EWA10460

### WARNING

- The front and rear tires should be of the same make and design, otherwise the handling characteristics of the vehicle cannot be guaranteed.
- After extensive tests, only the tires listed below have been approved for this model by Yamaha Motor Co., Ltd.

#### Front tire:

Size:

80/100-21M/C 51P

Manufacturer/model:

BRIDGESTONE/TW-301 F

#### Rear tire:

Size:

120/80-18M/C 62P

Manufacturer/model:

BRIDGESTONE/TW-302 F

EWA10570

### WARNING

- Have a Yamaha dealer replace excessively worn tires. Besides

being illegal, operating the motorcycle with excessively worn tires decreases riding stability and can lead to loss of control.

- The replacement of all wheel- and brake-related parts, including the tires, should be left to a Yamaha dealer, who has the necessary professional knowledge and experience.
- It is not recommended to patch a punctured tube. If unavoidable, however, patch the tube very carefully and replace it as soon as possible with a high-quality product.

## Spoke wheels

To maximize the performance, durability, and safe operation of your motorcycle, note the following points regarding the specified wheels.

- The wheel rims should be checked for cracks, bends or warpage, and the spokes for looseness or damage before each ride. If any damage is found, have a Yamaha dealer replace the wheel. Do not attempt even the smallest repair to the wheel. A deformed or cracked wheel must be replaced.
- The wheel should be balanced whenever either the tire or wheel has been changed or replaced. An unbalanced wheel can result in poor performance, adverse handling characteristics, and a shortened tire life.
- Ride at moderate speeds after changing a tire since the tire surface must first be “broken in” for it to develop its optimal characteristics.

# PERIODIC MAINTENANCE AND MINOR REPAIR

EAU22032

## Adjusting the clutch lever free play

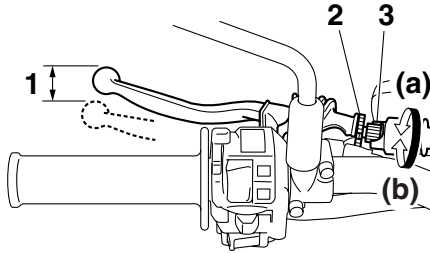

1. Clutch lever free play
2. Locknut (clutch lever)
3. Adjusting bolt (clutch lever)

The clutch lever free play should measure 10.0–15.0 mm (0.39–0.59 in) as shown. Periodically check the clutch lever free play and, if necessary, adjust it as follows.

1. Loosen the locknut at the clutch lever.
2. To increase the clutch lever free play, turn the clutch lever free play adjusting bolt in direction (a). To decrease the clutch lever free play, turn the adjusting bolt

in direction (b).

3. If the specified clutch lever free play could be obtained as described above, tighten the locknut and skip the rest of the procedure, otherwise, proceed as follows.
4. Fully turn the adjusting bolt in direction (a) to loosen the clutch cable.
5. Loosen the locknut further down the clutch cable.

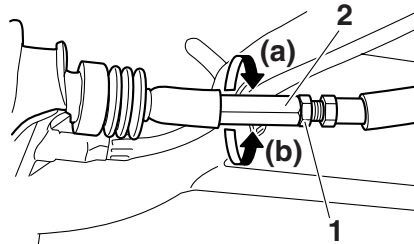

1. Locknut (clutch cable)
2. Clutch lever free play adjusting nut (clutch cable)

6. To increase the clutch lever free play, turn the clutch lever free play adjusting nut in direction (a). To decrease the clutch lever free play, turn the adjusting nut

in direction (b).

7. Tighten both locknuts.

# PERIODIC MAINTENANCE AND MINOR REPAIR

## Adjusting the brake lever free play

EAU22093

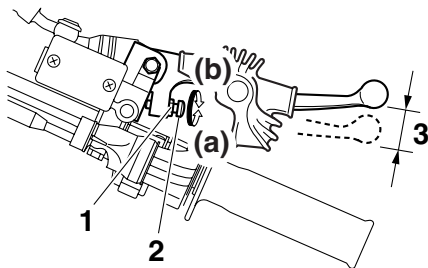

1. Locknut
2. Brake lever free play adjusting screw
3. Brake lever free play

The brake lever free play should measure 5.0–8.0 mm (0.20–0.31 in) as shown. Periodically check the brake lever free play and, if necessary, adjust it as follows.

1. Loosen the locknut at the brake lever.
2. To increase the brake lever free play, turn the brake lever free play adjusting screw in direction (a). To decrease the brake lever free play, turn the adjusting screw in direction (b).

3. Tighten the locknut.

EWA10630

### **WARNING**

- After adjusting the brake lever free play, check the free play and make sure that the brake is working properly.
- A soft or spongy feeling in the brake lever can indicate the presence of air in the hydraulic system. If there is air in the hydraulic system, have a Yamaha dealer bleed the system before operating the motorcycle. Air in the hydraulic system will diminish the braking performance, which may result in loss of control and an accident.

## Adjusting the rear brake light switch

EAU22271

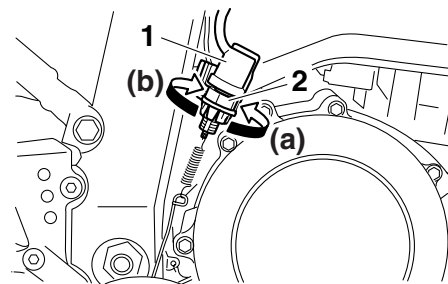

1. Rear brake light switch
2. Adjusting nut

The rear brake light switch, which is activated by the brake pedal, is properly adjusted when the brake light comes on just before braking takes effect. If necessary, adjust the brake light switch as follows.

Turn the rear brake light switch adjusting nut while holding the rear brake light switch in place. To make the brake light come on earlier, turn the adjusting nut in direction (a). To make the brake light come on later, turn the adjusting nut in direction (b).

# PERIODIC MAINTENANCE AND MINOR REPAIR

## Checking the front and rear brake pads

EAU22390

The front and rear brake pads must be checked for wear at the intervals specified in the periodic maintenance and lubrication chart.

### Front brake pads

EAU22430

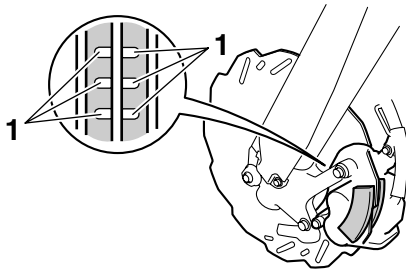

1. Wear indicator groove

Each front brake pad is provided with wear indicator grooves, which allow you to check the brake pad wear without having to disassemble the brake. To check the brake pad wear, check the wear indicator grooves. If a brake pad has worn to the point that the wear

indicator grooves have almost disappeared, have a Yamaha dealer replace the brake pads as a set.

### Rear brake pads

EAU45300

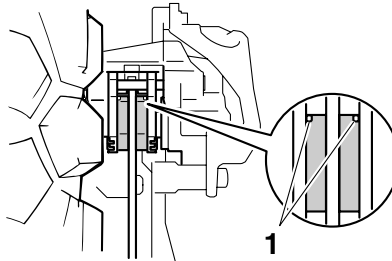

1. Wear indicator

Each rear brake pad is provided with a wear indicator, which allows you to check the brake pad wear without having to disassemble the brake. To check the brake pad wear, check if the brake pad has worn to the wear indicator. If a brake pad has worn to the indicator, have a Yamaha dealer replace the brake pads as a set.

## Checking the brake fluid level

EAU22580

### Front brake

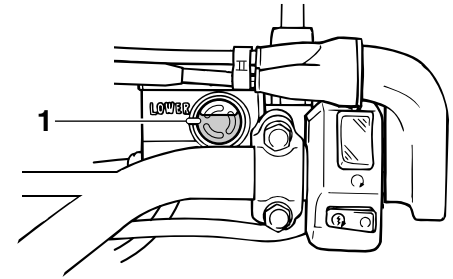

1. Minimum level mark

### Rear brake

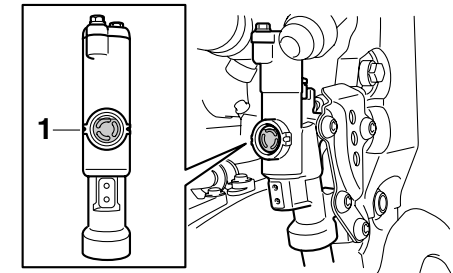

1. Minimum level mark

Insufficient brake fluid may allow air to

# PERIODIC MAINTENANCE AND MINOR REPAIR

enter the brake system, possibly causing it to become ineffective.

Before riding, check that the brake fluid is above the minimum level mark and replenish if necessary. A low brake fluid level may indicate worn brake pads and/or brake system leakage. If the brake fluid level is low, be sure to check the brake pads for wear and the brake system for leakage.

Observe these precautions:

- When checking the fluid level, make sure that the top of the brake fluid reservoir is level.
- Use only the recommended quality brake fluid, otherwise the rubber seals may deteriorate, causing leakage and poor braking performance.

**Recommended brake fluid:**  
DOT 4

- Refill with the same type of brake fluid. Mixing fluids may result in a harmful chemical reaction and lead to poor braking performance.
- Be careful that water does not enter the brake fluid reservoir when

refilling. Water will significantly lower the boiling point of the fluid and may result in vapor lock.

- Brake fluid may deteriorate painted surfaces or plastic parts. Always clean up spilled fluid immediately.
- As the brake pads wear, it is normal for the brake fluid level to gradually go down. However, if the brake fluid level goes down suddenly, have a Yamaha dealer check the cause.

EAU22730

## Changing the brake fluid

Have a Yamaha dealer change the brake fluid at the intervals specified in the NOTE after the periodic maintenance and lubrication chart. In addition, have the oil seals of the master cylinders and calipers as well as the brake hoses replaced at the intervals listed below or whenever they are damaged or leaking.

- Oil seals: Replace every two years.
- Brake hoses: Replace every four years.



# PERIODIC MAINTENANCE AND MINOR REPAIR

## Drive chain slack

EAU22760

The drive chain slack should be checked before each ride and adjusted if necessary.

## To check the drive chain slack

EAU22773

1. Place the motorcycle on the side-stand.

### NOTE:

When checking and adjusting the drive chain slack, there should be no weight on the motorcycle.

2. Shift the transmission into the neutral position.
3. Move the rear wheel by pushing the motorcycle to locate the tightest portion of the drive chain, and then measure the drive chain slack as shown.

### Drive chain slack:

38.0–48.0 mm (1.50–1.89 in)

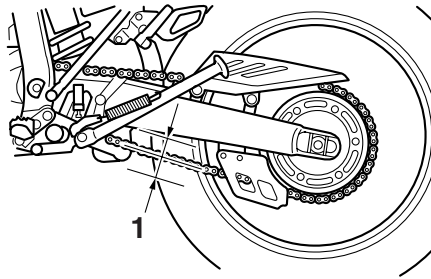

1. Drive chain slack

4. If the drive chain slack is incorrect, adjust it as follows.

EAU22942

## To adjust the drive chain slack

1. Loosen the axle nut and the locknut on each side of the swingarm.
2. To tighten the drive chain, turn the adjusting bolt on each side of the swingarm in direction (a). To loosen the drive chain, turn the adjusting bolt on each side of the swingarm in direction (b), and then push the rear wheel forward.

### NOTE:

Using the alignment marks on each side of the swingarm, make sure that

both chain pullers are in the same position for proper wheel alignment.

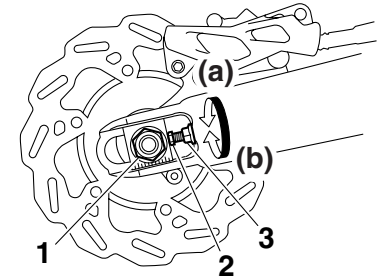

1. Axle nut
2. Drive chain slack adjusting bolt
3. Locknut

### CAUTION:

Improper drive chain slack will overload the engine as well as other vital parts of the motorcycle and can lead to chain slippage or breakage. To prevent this from occurring, keep the drive chain slack within the specified limits.

3. Tighten the locknuts, and then tighten the axle nut to the specified torque.

ECA10570

# PERIODIC MAINTENANCE AND MINOR REPAIR

---

## Tightening torque:

Axle nut:

125 Nm (12.5 m·kgf, 90.4 ft·lbf)

EAU23022

ECA11110

## Cleaning and lubricating the drive chain

The drive chain must be cleaned and lubricated at the intervals specified in the periodic maintenance and lubrication chart, otherwise it will quickly wear out, especially when riding in dusty or wet areas. Service the drive chain as follows.

ECA10581

### CAUTION:

**The drive chain must be lubricated after washing the motorcycle and riding in the rain.**

1. Clean the drive chain with kerosene and a small soft brush.

ECA11120

### CAUTION:

**To prevent damaging the O-rings, do not clean the drive chain with steam cleaners, high-pressure washers or inappropriate solvents.**

2. Wipe the drive chain dry.
3. Thoroughly lubricate the drive chain with a special O-ring chain lubricant.

### CAUTION:

**Do not use engine oil or any other lubricants for the drive chain, as they may contain substances that could damage the O-rings.**

# PERIODIC MAINTENANCE AND MINOR REPAIR

EAU23100

## Checking and lubricating the cables

The operation of all control cables and the condition of the cables should be checked before each ride, and the cables and cable ends should be lubricated if necessary. If a cable is damaged or does not move smoothly, have a Yamaha dealer check or replace it.

**Recommended lubricant:**  
Engine oil

EWA10720

### **WARNING**

**Damage to the outer sheath may interfere with proper cable operation and will cause the inner cable to rust. Replace a damaged cable as soon as possible to prevent unsafe conditions.**

EAU23111

## Checking and lubricating the throttle grip and cable

The operation of the throttle grip should be checked before each ride. In addition, the cable should be lubricated at the intervals specified in the periodic maintenance chart.

EAU44271

## Checking and lubricating the brake and shift pedals

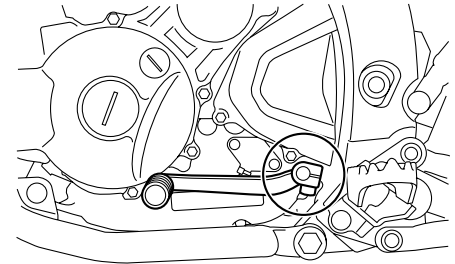
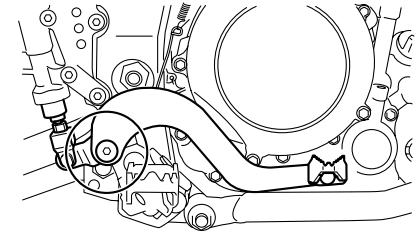

The operation of the brake and shift pedals should be checked before each ride, and the pedal pivots should be lubricated if necessary.

# PERIODIC MAINTENANCE AND MINOR REPAIR

**Recommended lubricant:**  
Lithium-soap-based grease

## Checking and lubricating the brake and clutch levers

EAU23142

bricated if necessary.

**Recommended lubricants:**  
Brake lever:  
Silicone grease  
Clutch lever:  
Lithium-soap-based grease

### Brake lever

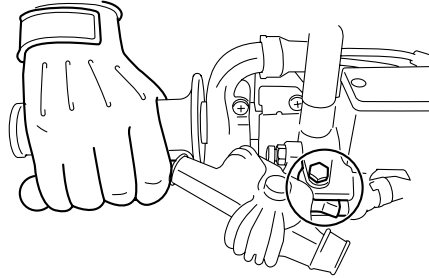

### Clutch lever

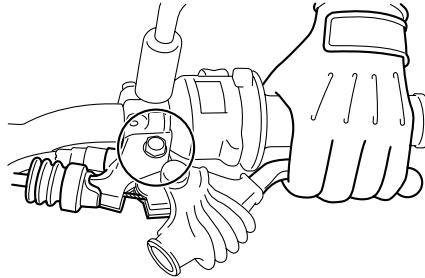

The operation of the brake and clutch levers should be checked before each ride, and the lever pivots should be lu-

# PERIODIC MAINTENANCE AND MINOR REPAIR

## Checking and lubricating the sidestand

EAU23201

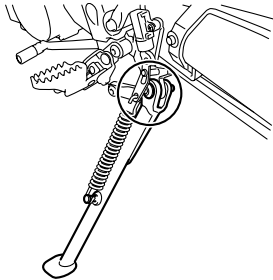

The operation of the sidestand should be checked before each ride, and the sidestand pivot and metal-to-metal contact surfaces should be lubricated if necessary.

EWA10730

### **WARNING**

**If the sidestand does not move up and down smoothly, have a Yamaha dealer check or repair it.**

**Recommended lubricant:**  
Lithium-soap-based grease

## Lubricating the rear suspension

EAU23250

The pivoting points of the rear suspension must be lubricated at the intervals specified in the periodic maintenance and lubrication chart.

**Recommended lubricant:**  
Lithium-soap-based grease

## Checking the front fork

EAU23271

The condition and operation of the front fork must be checked as follows at the intervals specified in the periodic maintenance and lubrication chart.

### To check the condition

EWA10750

### **WARNING**

**Securely support the vehicle so that there is no danger of it falling over.**

Check the inner tubes for scratches, damage and excessive oil leakage.

### To check the operation

1. Place the vehicle on a level surface and hold it in an upright position.
2. While applying the front brake, push down hard on the handlebars several times to check if the front fork compresses and rebounds smoothly.

# PERIODIC MAINTENANCE AND MINOR REPAIR

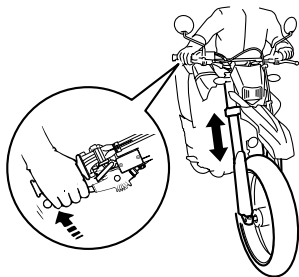

ECA10590

## CAUTION:

If any damage is found or the front fork does not operate smoothly, have a Yamaha dealer check or repair it.

6

EAU23280

## Checking the steering

Worn or loose steering bearings may cause danger. Therefore, the operation of the steering must be checked as follows at the intervals specified in the periodic maintenance and lubrication chart.

1. Place a stand under the engine to raise the front wheel off the ground.

EWA10750

## WARNING

Securely support the vehicle so that there is no danger of it falling over.

2. Hold the lower ends of the front fork legs and try to move them forward and backward. If any free play can be felt, have a Yamaha dealer check or repair the steering.

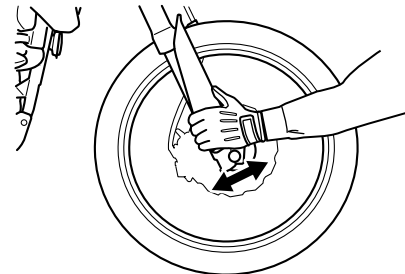

# PERIODIC MAINTENANCE AND MINOR REPAIR

EAU23290

## Checking the wheel bearings

The front and rear wheel bearings must be checked at the intervals specified in the periodic maintenance and lubrication chart. If there is play in the wheel hub or if the wheel does not turn smoothly, have a Yamaha dealer check the wheel bearings.

EAU23390

## Battery

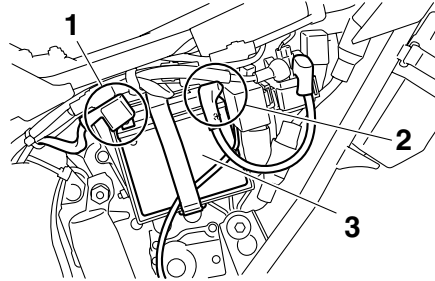

1. Negative battery terminal
2. Positive battery terminal
3. Battery

The battery is located behind panel D. (See page 6-6.)

This model is equipped with a sealed-type (MF) battery, which does not require any maintenance. There is no need to check the electrolyte or to add distilled water.

### To charge the battery

Have a Yamaha dealer charge the battery as soon as possible if it seems to have discharged. Keep in mind that the battery tends to discharge more quickly

if the vehicle is equipped with optional electrical accessories.

EWA10760

### **⚠ WARNING**

- **Electrolyte is poisonous and dangerous since it contains sulfuric acid, which causes severe burns. Avoid any contact with skin, eyes or clothing and always shield your eyes when working near batteries. In case of contact, administer the following FIRST AID.**
  - **EXTERNAL:** Flush with plenty of water.
  - **INTERNAL:** Drink large quantities of water or milk and immediately call a physician.
  - **EYES:** Flush with water for 15 minutes and seek prompt medical attention.
- **Batteries produce explosive hydrogen gas. Therefore, keep sparks, flames, cigarettes, etc., away from the battery and provide sufficient ventilation when charging it in an enclosed space.**
- **KEEP THIS AND ALL BATTER-**

# PERIODIC MAINTENANCE AND MINOR REPAIR

**IES OUT OF THE REACH OF CHILDREN.**

## To store the battery

1. If the model will not be used for more than one month, remove the battery, fully charge it, and then place it in a cool, dry place.
2. If the battery will be stored for more than two months, check it at least once a month and fully charge it if necessary.
3. Fully charge the battery before installation.
4. After installation, make sure that the battery leads are properly connected to the battery terminals.

ECA10630

## CAUTION:

- **Always keep the battery charged. Storing a discharged battery can cause permanent battery damage.**
- **To charge a sealed-type (MF) battery, a special (constant-voltage) battery charger is required. Using a conventional battery charger will damage the battery.**

**If you do not have access to a sealed-type (MF) battery charger, have a Yamaha dealer charge your battery.**

EAU23541

## Replacing the fuses

The main fuse is located behind panel D. (See page 6-6.)

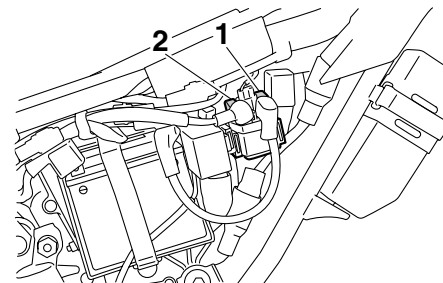

1. Main fuse
2. Spare main fuse

The fuse box, which contains the fuses for the individual circuits, is located behind panel C. (See page 6-6.)



# PERIODIC MAINTENANCE AND MINOR REPAIR

EAU45210

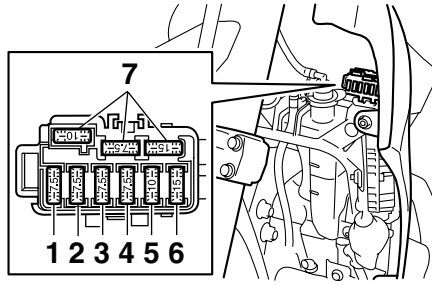

1. Fuel injection system fuse
2. Radiator fan fuse
3. Backup fuse
4. Ignition fuse
5. Signaling system fuse
6. Headlight fuse
7. Spare fuse

If a fuse is blown, replace it as follows.

1. Turn the key to "OFF" and turn off the electrical circuit in question.
2. Remove the blown fuse, and then install a new fuse of the specified amperage.

## Specified fuses:

- Main fuse:  
30.0 A
- Ignition fuse:  
7.5 A
- Signaling system fuse:  
10.0 A
- Headlight fuse:  
15.0 A
- Radiator fan fuse:  
7.5 A
- Backup fuse:  
7.5 A
- Fuel injection system fuse:  
7.5 A

ECA10640

## CAUTION:

**Do not use a fuse of a higher amperage rating than recommended to avoid causing extensive damage to the electrical system and possibly a fire.**

3. Turn the key to "ON" and turn on the electrical circuit in question to check if the device operates.
4. If a fuse immediately blows again, have a Yamaha dealer check the electrical system.

## Replacing the headlight bulb

This model is equipped with a quartz bulb headlight. If the headlight bulb burns out, replace it as follows.

1. Remove the headlight cowling together with the headlight unit by removing the bolts and pulling upward as shown.

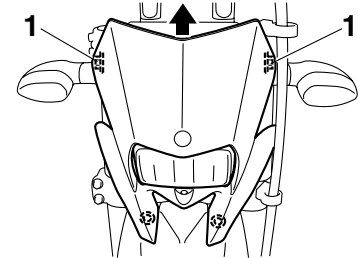

1. Bolt

2. Disconnect the headlight coupler, and then remove the bulb cover.

# PERIODIC MAINTENANCE AND MINOR REPAIR

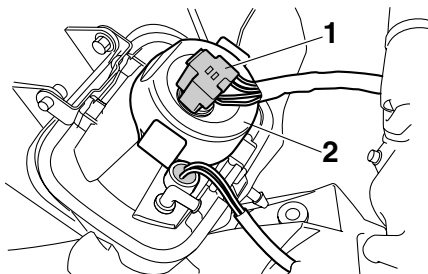

1. Headlight coupler
2. Bulb cover

3. Unhook the headlight bulb holder, and then remove the defective bulb.

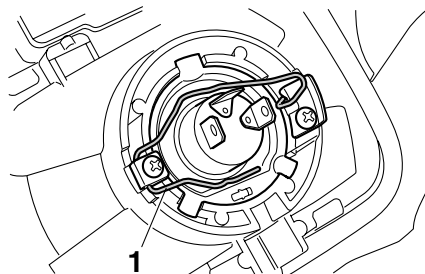

1. Headlight bulb holder

EWA10790

## **WARNING**

**Headlight bulbs get very hot. Therefore, keep flammable products away from a lit headlight bulb, and do not touch the bulb until it has cooled down.**

4. Place a new headlight bulb into position, and then secure it with the bulb holder.

ECA10660

## **CAUTION:**

**Do not touch the glass part of the headlight bulb to keep it free from oil, otherwise the transparency of the glass, the luminosity of the bulb, and the bulb life will be adversely af-**

**ected. Thoroughly clean off any dirt and fingerprints on the headlight bulb using a cloth moistened with alcohol or thinner.**

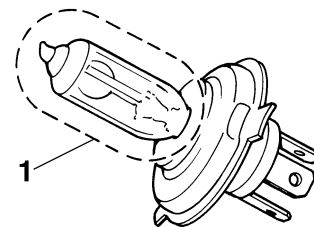

1. Do not touch the glass part of the bulb.
5. Install the headlight bulb cover, and then connect the coupler.
6. Install the headlight cowling (together with the headlight unit) by placing it in the original position, and then installing the bolts.
7. Have a Yamaha dealer adjust the headlight beam if necessary.

# PERIODIC MAINTENANCE AND MINOR REPAIR

## Tail/brake light

EAU24181

This model is equipped with an LED-type tail/brake light. If the tail/brake light does not come on, have a Yamaha dealer check it.

## Replacing a turn signal light bulb

EAU24202

1. Remove the turn signal light lens by removing the screw.

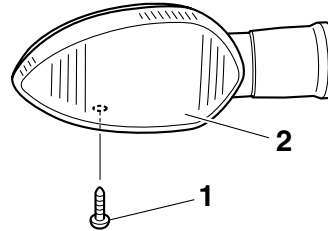

1. Screw
2. Turn signal light lens

2. Remove the defective bulb by pushing it in and turning it counter-clockwise.

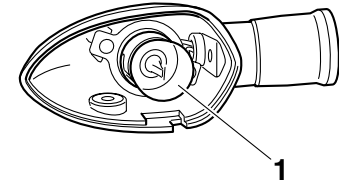

1. Turn signal light bulb
3. Insert a new bulb into the socket, push it in, and then turn it clockwise until it stops.
4. Install the lens by installing the screw.

### CAUTION:

**Do not overtighten the screw, otherwise the lens may break.**

ECA11190

# PERIODIC MAINTENANCE AND MINOR REPAIR

EAU24310

## Replacing the license plate light bulb

1. Remove the license plate light unit by removing the screws.

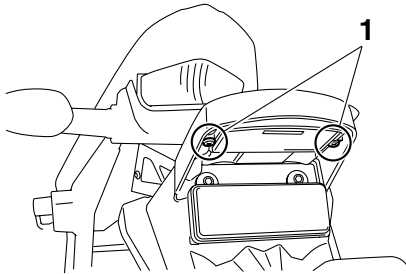

1. Screw

2. Remove the socket (together with the bulb) by pulling it out.

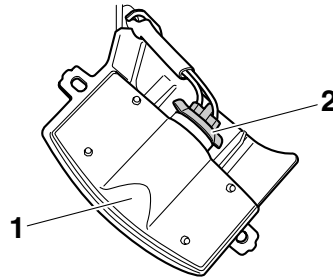

1. License plate light unit
2. License plate light bulb socket

3. Remove the defective bulb by pulling it out.
4. Insert a new bulb into the socket.
5. Install the socket (together with the bulb) by pushing it in.
6. Install the license plate light unit by installing the screws.

EAU45220

## Replacing an auxiliary light bulb

If the auxiliary light bulb burns out, replace it as follows.

1. Remove the headlight unit. (See page 6-33.)
2. Remove the auxiliary light socket (together with the bulb) by pulling it out.

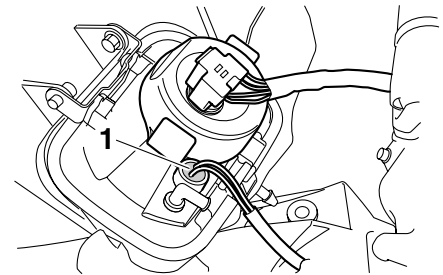

1. Auxiliary light bulb socket

3. Remove the defective bulb by pulling it out.
4. Insert a new bulb into the socket.
5. Install the auxiliary light socket (together with the bulb) by pushing it in.
6. Install the headlight unit.

# PERIODIC MAINTENANCE AND MINOR REPAIR

EAU24350

## Supporting the motorcycle

Since this model is not equipped with a centerstand, follow these precautions when removing the front and rear wheel or performing other maintenance requiring the motorcycle to stand upright. Check that the motorcycle is in a stable and level position before starting any maintenance. A strong wooden box can be placed under the engine for added stability.

## To service the front wheel

1. Stabilize the rear of the motorcycle by using a motorcycle stand or, if an additional motorcycle stand is not available, by placing a jack under the frame in front of the rear wheel.
2. Raise the front wheel off the ground by using a motorcycle stand.

## To service the rear wheel

Raise the rear wheel off the ground by using a motorcycle stand or, if a motorcycle stand is not available, by placing a jack either under each side of the

frame in front of the rear wheel or under each side of the swingarm.

EAU24360

## Front wheel

EAU45160

## To remove the front wheel

EWA10820

### **WARNING**

- It is advisable to have a Yamaha dealer service the wheel.
- Securely support the motorcycle so that there is no danger of it falling over.

1. Loosen the front wheel axle pinch bolts and axle nut.

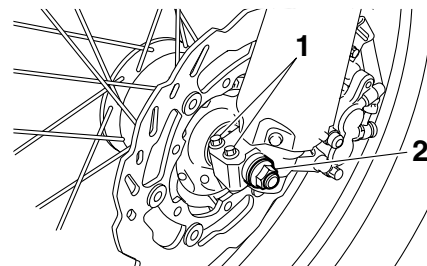

1. Front wheel axle pinch bolt
2. Axle nut

# PERIODIC MAINTENANCE AND MINOR REPAIR

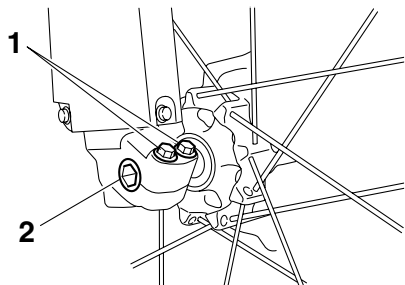

1. Front wheel axle pinch bolt
2. Wheel axle

2. Lift the front wheel off the ground according to the procedure on page 6-37.
3. Remove the axle nut.
4. Pull the wheel axle out, and then remove the wheel.

ECA11070

## CAUTION:

**Do not apply the brake after the wheel has been removed together with the brake disc, otherwise the brake pads will be forced shut.**

EAU45170

## To install the front wheel

1. Lift the wheel up between the fork

legs.

## NOTE:

Make sure that there is enough space between the brake pads before installing the brake caliper onto the brake disc.

2. Insert the wheel axle.
3. Install the wheel axle pinch bolts and axle nut.
4. Lower the front wheel so that it is on the ground.
5. Tighten the axle nut and the wheel axle pinch bolts to their specified torques.

## Tightening torques:

Axle nut:

63 Nm (6.3 m·kgf, 45.6 ft·lbf)

Wheel axle pinch bolt:

23 Nm (2.3 m·kgf, 16.6 ft·lbf)

6. Push down hard on the handlebar several times to check for proper fork operation.

EAU25080

## Rear wheel

EAU45180

## To remove the rear wheel

EWA10820

## ! WARNING

- It is advisable to have a Yamaha dealer service the wheel.
- Securely support the motorcycle so that there is no danger of it falling over.

1. Loosen the axle nut.
2. Lift the rear wheel off the ground according to the procedure on page 6-37.
3. Remove the axle nut and washer.
4. Loosen the locknut and drive chain adjusting bolt on each side of the swingarm.

# PERIODIC MAINTENANCE AND MINOR REPAIR

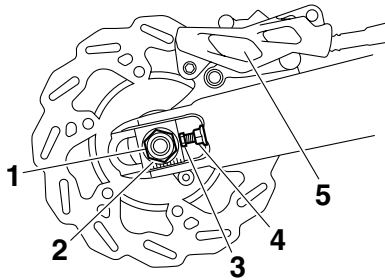

1. Axle nut
2. Washer
3. Drive chain slack adjusting bolt
4. Locknut
5. Brake caliper

5. While supporting the brake caliper, pull the wheel axle out.

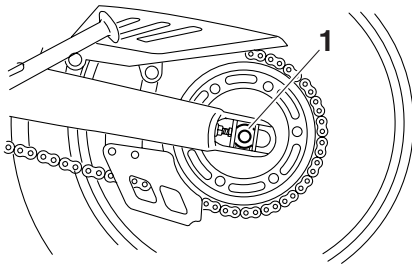

1. Wheel axle

6. Push the wheel forward, and then remove the drive chain from the rear sprocket.

**NOTE:** \_\_\_\_\_  
The drive chain does not need to be disassembled in order to remove and install the rear wheel.

7. Remove the wheel.

ECA11070

**CAUTION:** \_\_\_\_\_  
**Do not apply the brake after the wheel has been removed together with the brake disc, otherwise the brake pads will be forced shut.**

EAU45190

## To install the rear wheel

1. Install the wheel and the brake caliper bracket by inserting the wheel axle from the left-hand side.

**NOTE:** \_\_\_\_\_

- Make sure that the retainer on the brake caliper bracket is inserted into the slot in the swingarm.
- Make sure that there is enough space between the brake pads before installing the wheel.

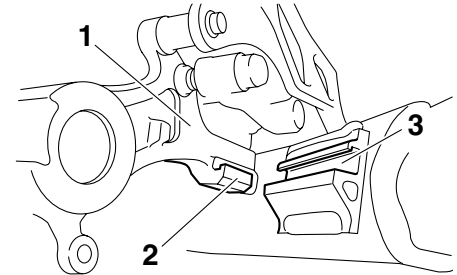

1. Brake caliper bracket
2. Retainer
3. Slot

2. Install the drive chain onto the rear sprocket.
3. Install the washer and the axle nut, and then lower the rear wheel so that it is on the ground.
4. Adjust the drive chain slack. (See page 6-25.)
5. Tighten the axle nut to the specified torque.

### Tightening torque:

Axle nut:  
125 Nm (12.5 m·kgf, 90.4 ft·lbf)

# PERIODIC MAINTENANCE AND MINOR REPAIR

---

EAU25870

## Troubleshooting

Although Yamaha motorcycles receive a thorough inspection before shipment from the factory, trouble may occur during operation. Any problem in the fuel, compression, or ignition systems, for example, can cause poor starting and loss of power.

The following troubleshooting charts represent quick and easy procedures for checking these vital systems yourself. However, should your motorcycle require any repair, take it to a Yamaha dealer, whose skilled technicians have the necessary tools, experience, and know-how to service the motorcycle properly.

Use only genuine Yamaha replacement parts. Imitation parts may look like Yamaha parts, but they are often inferior, have a shorter service life and can lead to expensive repair bills.



# PERIODIC MAINTENANCE AND MINOR REPAIR

EAU42130

## Troubleshooting charts

### Starting problems or poor engine performance

EWA10840



**WARNING**

Keep away open flames and do not smoke while checking or working on the fuel system.

#### 1. Fuel

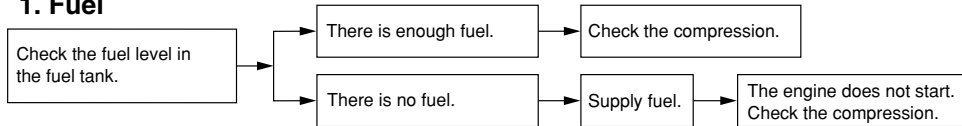

#### 2. Compression

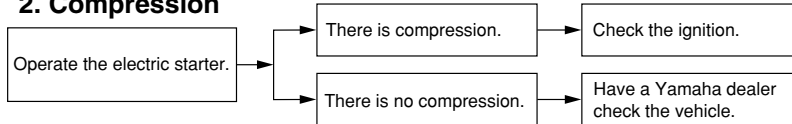

#### 3. Ignition

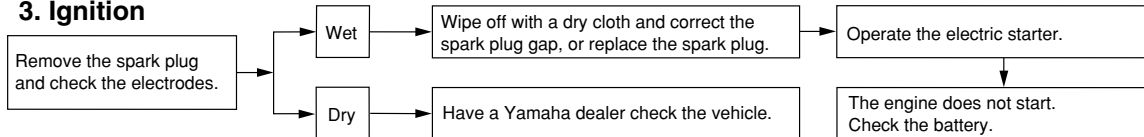

#### 4. Battery

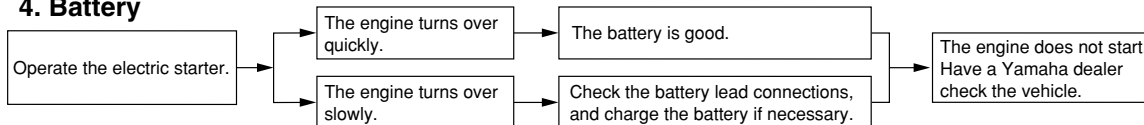

# PERIODIC MAINTENANCE AND MINOR REPAIR

## Engine overheating

EWA10400

### WARNING

- Do not remove the radiator cap when the engine and radiator are hot. Scalding hot fluid and steam may be blown out under pressure, which could cause serious injury. Be sure to wait until the engine has cooled.
- After removing the radiator cap retaining bolt, place a thick rag, like a towel, over the radiator cap, and then slowly rotate the cap counterclockwise to the detent to allow any residual pressure to escape. When the hissing sound has stopped, press down on the cap while turning it counterclockwise, and then remove the cap.

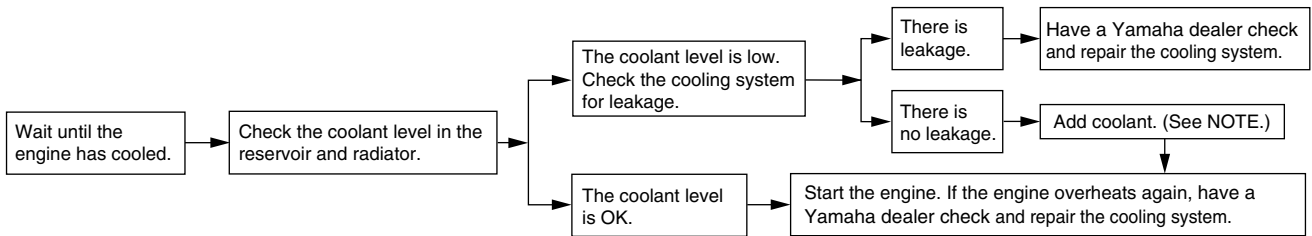

6

### NOTE:

If coolant is not available, tap water can be temporarily used instead, provided that it is changed to the recommended coolant as soon as possible.

## Matte color caution

EAU37833

ECA15192

### CAUTION:

Some models are equipped with matte colored finished parts. Be sure to consult a Yamaha dealer for advice on what products to use before cleaning the vehicle. Using a brush, harsh chemical products or cleaning compounds when cleaning these parts will scratch or damage their surface. Wax also should not be applied to any matte colored finished parts.

## Care

EAU26002

While the open design of a motorcycle reveals the attractiveness of the technology, it also makes it more vulnerable. Rust and corrosion can develop even if high-quality components are used. A rusty exhaust pipe may go unnoticed on a car, however, it detracts from the overall appearance of a motorcycle. Frequent and proper care does not only comply with the terms of the warranty, but it will also keep your motorcycle looking good, extend its life and optimize its performance.

## Before cleaning

1. Cover the muffler outlet with a plastic bag after the engine has cooled down.
2. Make sure that all caps and covers as well as all electrical couplers and connectors, including the spark plug cap, are tightly installed.
3. Remove extremely stubborn dirt, like oil burnt onto the crankcase, with a degreasing agent and a brush, but never apply such prod-

ucts onto seals, gaskets, sprockets, the drive chain and wheel axles. Always rinse the dirt and degreaser off with water.

## Cleaning

ECA10771

### CAUTION:

- Avoid using strong acidic wheel cleaners, especially on spoked wheels. If such products are used on hard-to-remove dirt, do not leave the cleaner on the affected area any longer than instructed. Also, thoroughly rinse the area off with water, immediately dry it, and then apply a corrosion protection spray.
- Improper cleaning can damage plastic parts such as cowlings, panels, windshields, headlight lenses, meter lenses, etc. Use only a soft, clean cloth or sponge with mild detergent and water to clean plastic.
- Do not use any harsh chemical products on plastic parts. Be sure to avoid using cloths or sponges which have been in

# MOTORCYCLE CARE AND STORAGE

---

ECA10790

contact with strong or abrasive cleaning products, solvent or thinner, fuel (gasoline), rust removers or inhibitors, brake fluid, antifreeze or electrolyte.

- Do not use high-pressure washers or steam-jet cleaners since they cause water seepage and deterioration in the following areas: seals (of wheel and swing-arm bearings, fork and brakes), electric components (couplers, connectors, instruments, switches and lights), breather hoses and vents.
- For motorcycles equipped with a windshield: Do not use strong cleaners or hard sponges as they will cause dulling or scratching. Some cleaning compounds for plastic may leave scratches on the windshield. Test the product on a small hidden part of the windshield to make sure that it does not leave any marks. If the windshield is scratched, use a quality plastic polishing compound after

## washing.

---

### After normal use

Remove dirt with warm water, a mild detergent, and a soft, clean sponge, and then rinse thoroughly with clean water. Use a toothbrush or bottlebrush for hard-to-reach areas. Stubborn dirt and insects will come off more easily if the area is covered with a wet cloth for a few minutes before cleaning.

### After riding in the rain, near the sea or on salt-sprayed roads

Since sea salt or salt sprayed on roads during winter are extremely corrosive in combination with water, carry out the following steps after each ride in the rain, near the sea or on salt-sprayed roads.

### **NOTE:**

---

Salt sprayed on roads in the winter may remain well into spring.

---

1. Clean the motorcycle with cold water and a mild detergent, after the engine has cooled down.

### **CAUTION:**

---

**Do not use warm water since it increases the corrosive action of the salt.**

---

2. Apply a corrosion protection spray on all metal, including chrome- and nickel-plated, surfaces to prevent corrosion.

### **After cleaning**

1. Dry the motorcycle with a chamois or an absorbing cloth.
2. Immediately dry the drive chain and lubricate it to prevent it from rusting.
3. Use a chrome polish to shine chrome, aluminum and stainless-steel parts, including the exhaust system. (Even the thermally induced discoloring of stainless-steel exhaust systems can be removed through polishing.)
4. To prevent corrosion, it is recommended to apply a corrosion protection spray on all metal, including chrome- and nickel-plated, surfaces.

# MOTORCYCLE CARE AND STORAGE

EAU43200

5. Use spray oil as a universal cleaner to remove any remaining dirt.
6. Touch up minor paint damage caused by stones, etc.
7. Wax all painted surfaces.
8. Let the motorcycle dry completely before storing or covering it.

EWA11130

## WARNING

- Make sure that there is no oil or wax on the brakes or tires.
- If necessary, clean the brake discs and brake linings with a regular brake disc cleaner or acetone, and wash the tires with warm water and a mild detergent. Before riding at higher speeds, test the motorcycle's braking performance and cornering behavior.

ECA10800

## CAUTION:

- Apply spray oil and wax sparingly and make sure to wipe off any excess.
- Never apply oil or wax to any rubber and plastic parts, but treat them with a suitable care

product.

- Avoid using abrasive polishing compounds as they will wear away the paint.

**NOTE:** \_\_\_\_\_  
Consult a Yamaha dealer for advice on what products to use.

## Storage

### Short-term

Always store your motorcycle in a cool, dry place and, if necessary, protect it against dust with a porous cover.

ECA10810

## CAUTION:

- Storing the motorcycle in a poorly ventilated room or covering it with a tarp, while it is still wet, will allow water and humidity to seep in and cause rust.
- To prevent corrosion, avoid damp cellars, stables (because of the presence of ammonia) and areas where strong chemicals are stored.

### Long-term

Before storing your motorcycle for several months:

1. Follow all the instructions in the "Care" section of this chapter.
2. Fill up the fuel tank and add fuel stabilizer (if available) to prevent the fuel tank from rusting and the

# MOTORCYCLE CARE AND STORAGE

---

fuel from deteriorating.

3. Perform the following steps to protect the cylinder, piston rings, etc. from corrosion.

- a. Remove the spark plug cap and spark plug.
- b. Pour a teaspoonful of engine oil into the spark plug bore.
- c. Install the spark plug cap onto the spark plug, and then place the spark plug on the cylinder head so that the electrodes are grounded. (This will limit sparking during the next step.)
- d. Turn the engine over several times with the starter. (This will coat the cylinder wall with oil.)
- e. Remove the spark plug cap from the spark plug, and then install the spark plug and the spark plug cap.

EWA10950

## WARNING

**To prevent damage or injury from sparking, make sure to ground the spark plug electrodes while turning the engine over.**

---

4. Lubricate all control cables and the

pivoting points of all levers and pedals as well as of the sidestand/centerstand.

5. Check and, if necessary, correct the tire air pressure, and then lift the motorcycle so that both of its wheels are off the ground. Alternatively, turn the wheels a little every month in order to prevent the tires from becoming degraded in one spot.
6. Cover the muffler outlet with a plastic bag to prevent moisture from entering it.
7. Remove the battery and fully charge it. Store it in a cool, dry place and charge it once a month. Do not store the battery in an excessively cold or warm place [less than 0 °C (30 °F) or more than 30 °C (90 °F)]. For more information on storing the battery, see page 6-31.

## NOTE:

Make any necessary repairs before storing the motorcycle.

---

EAU2633N

## Dimensions:

- Overall length:  
2180 mm (85.8 in)
- Overall width:  
810 mm (31.9 in)
- Overall height:  
1230 mm (48.4 in)
- Seat height:  
930 mm (36.6 in)
- Wheelbase:  
1420 mm (55.9 in)
- Ground clearance:  
300 mm (11.81 in)
- Minimum turning radius:  
2300 mm (90.6 in)

## Weight:

- With oil and fuel:  
134.0 kg (295 lb)

## Engine:

- Engine type:  
Liquid cooled 4-stroke, DOHC
- Cylinder arrangement:  
Forward-inclined single cylinder
- Displacement:  
250.0 cm<sup>3</sup>
- Bore × stroke:  
77.0 × 53.6 mm (3.03 × 2.11 in)
- Compression ratio:  
11.80 :1
- Starting system:  
Electric starter

## Lubrication system:

Wet sump

## Engine oil:

Type:  
SAE 20W-40

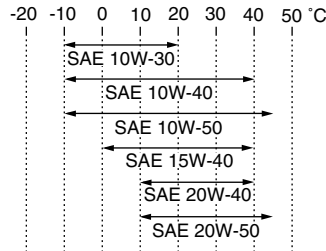

## Recommended engine oil grade:

API service SG type or higher, JASO standard MA

## Engine oil quantity:

- Without oil filter element replacement:  
1.30 L (1.37 US qt) (1.14 Imp.qt)
- With oil filter element replacement:  
1.40 L (1.48 US qt) (1.23 Imp.qt)

## Cooling system:

- Coolant reservoir capacity (up to the maximum level mark):  
0.25 L (0.26 US qt) (0.22 Imp.qt)
- Radiator capacity (including all routes):  
0.90 L (0.95 US qt) (0.79 Imp.qt)

## Air filter:

- Air filter element:  
Wet element

## Fuel:

- Recommended fuel:  
Premium unleaded gasoline only
- Fuel tank capacity:  
7.6 L (2.01 US gal) (1.67 Imp.gal)
- Fuel reserve amount:  
2.1 L (0.55 US gal) (0.46 Imp.gal)

## Fuel injection:

- Throttle body:  
Manufacturer:  
MIKUNI
- Type/quantity:  
38EIS/1

## Spark plug (s):

- Manufacturer/model:  
NGK/CR9EK
- Spark plug gap:  
0.6–0.7 mm (0.024–0.028 in)

## Clutch:

- Clutch type:  
Wet, multiple-disc

## Transmission:

- Primary reduction system:  
Spur gear
- Primary reduction ratio:  
78/25 (3.120)
- Secondary reduction system:  
Chain drive
- Secondary reduction ratio:  
43/13 (3.307)
- Transmission type:  
Constant mesh 6-speed

# SPECIFICATIONS

## Operation:

Left foot operation

## Gear ratio:

1st:

37/14 (2.642)

2nd:

29/16 (1.813)

3rd:

29/22 (1.318)

4th:

26/25 (1.040)

5th:

24/27 (0.888)

6th:

22/28 (0.786)

## Chassis:

Frame type:

Semi double cradle

Caster angle:

26.67 °

Trail:

111.0 mm (4.37 in)

## Front tire:

Type:

With tube

Size:

80/100-21M/C 51P

Manufacturer/model:

BRIDGESTONE/TW-301 F

## Rear tire:

Type:

With tube

Size:

120/80-18M/C 62P

Manufacturer/model:

BRIDGESTONE/TW-302 F

## Loading:

Maximum load:

185 kg (408 lb)

\* (Total weight of rider, passenger, cargo and accessories)

## Tire air pressure (measured on cold tires):

Loading condition:

0–90 kg (0–198 lb)

Front:

125 kPa (18 psi) (1.25 kgf/cm<sup>2</sup>)

Rear:

175 kPa (25 psi) (1.75 kgf/cm<sup>2</sup>)

Loading condition:

90–185 kg (198–408 lb)

Front:

150 kPa (22 psi) (1.50 kgf/cm<sup>2</sup>)

Rear:

200 kPa (29 psi) (2.00 kgf/cm<sup>2</sup>)

## Front wheel:

Wheel type:

Spoke wheel

Rim size:

21x1.60

## Rear wheel:

Wheel type:

Spoke wheel

Rim size:

18x2.15

## Front brake:

Type:

Single disc brake

Operation:

Right hand operation

Recommended fluid:

DOT 4

## Rear brake:

Type:

Single disc brake

Operation:

Right foot operation

Recommended fluid:

DOT 4

## Front suspension:

Type:

Telescopic fork

Spring/shock absorber type:

Coil spring/oil damper

Wheel travel:

270.0 mm (10.63 in)

## Rear suspension:

Type:

Swingarm (link suspension)

Spring/shock absorber type:

Coil spring/gas-oil damper

Wheel travel:

270.0 mm (10.63 in)

## Electrical system:

Ignition system:

Transistorized coil ignition (digital)

Charging system:

AC magneto



## Battery:

Model:

YTZ7S

Voltage, capacity:

12 V, 6.0 Ah

## Headlight:

Bulb type:

Halogen bulb

## Bulb voltage, wattage × quantity:

Headlight:

12 V, 60 W/55.0 W

Tail/brake light:

LED

Front turn signal light:

12 V, 10.0 W × 2

Rear turn signal light:

12 V, 10.0 W × 2

Auxiliary light:

12 V, 5.0 W × 1

License plate light:

12 V, 5.0 W

Meter lighting:

EL (Electroluminescent)

Neutral indicator light:

LED

High beam indicator light:

LED

Turn signal indicator light:

LED

Fuel level warning light:

LED

Coolant temperature warning light:

LED

Engine trouble warning light:

LED

## Fuses:

Main fuse:

30.0 A

Headlight fuse:

15.0 A

Signaling system fuse:

10.0 A

Ignition fuse:

7.5 A

Radiator fan fuse:

7.5 A

Fuel injection system fuse:

7.5 A

Backup fuse:

7.5 A

# CONSUMER INFORMATION

EAU26351

## Identification numbers

Record the key identification number, vehicle identification number and model label information in the spaces provided below for assistance when ordering spare parts from a Yamaha dealer or for reference in case the vehicle is stolen.

KEY IDENTIFICATION NUMBER:

VEHICLE IDENTIFICATION NUMBER:

MODEL LABEL INFORMATION:

9

EAU26381

## Key identification number

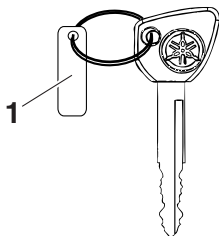

1. Key identification number

The key identification number is stamped into the key tag. Record this number in the space provided and use it for reference when ordering a new key.

EAU26400

## Vehicle identification number

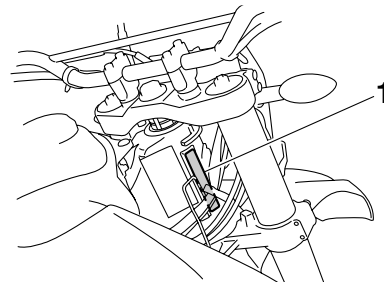

1. Vehicle identification number

The vehicle identification number is stamped into the steering head pipe. Record this number in the space provided.

**NOTE:** \_\_\_\_\_

The vehicle identification number is used to identify your motorcycle and may be used to register your motorcycle with the licensing authority in your area.

\_\_\_\_\_

EAU26460

## Model label

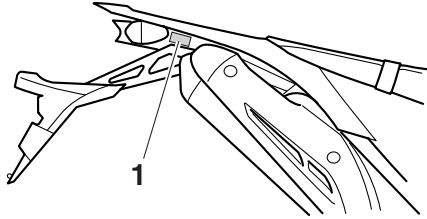

### 1. Model label

The model label is affixed to the location shown. Record the information on this label in the space provided. This information will be needed when ordering spare parts from a Yamaha dealer.

# INDEX

---

## A

- Air filter element and check hose,  
cleaning ..... 6-15
- Auxiliary light bulb, replacing ..... 6-36

## B

- Battery ..... 6-31
- Brake and clutch levers, checking and  
lubricating ..... 6-28
- Brake and shift pedals, checking and  
lubricating ..... 6-27
- Brake fluid, changing ..... 6-24
- Brake fluid level, checking ..... 6-23
- Brake lever ..... 3-10
- Brake lever free play, adjusting ..... 6-22
- Brake pedal ..... 3-10

## C

- Cables, checking and lubricating ..... 6-27
- Care ..... 7-1
- Catalytic converter ..... 3-12
- Clutch lever ..... 3-9
- Clutch lever free play, adjusting ..... 6-21
- Coolant ..... 6-12
- Coolant temperature warning light ..... 3-2

## D

- Dimmer switch ..... 3-9
- Drive chain, cleaning and lubricating ..... 6-26
- Drive chain slack ..... 6-25

## E

- Engine break-in ..... 5-3
- Engine idling speed ..... 6-17
- Engine oil and oil filter element ..... 6-9
- Engine stop switch ..... 3-9
- Engine trouble warning light ..... 3-3
- EXUP system ..... 3-17

## F

- Front and rear brake pads, checking ..... 6-23
- Front fork, adjusting ..... 3-13
- Front fork, bleeding ..... 3-15
- Front fork, checking ..... 6-29
- Fuel ..... 3-11
- Fuel consumption, tips for reducing ..... 5-3
- Fuel level warning light ..... 3-2
- Fuel tank cap ..... 3-11
- Fuses, replacing ..... 6-32

## H

- Handlebar switches ..... 3-8
- Headlight bulb, replacing ..... 6-33
- Helmet holder ..... 3-13
- High beam indicator light ..... 3-2
- Horn switch ..... 3-9

## I

- Identification numbers ..... 9-1
- Ignition circuit cut-off system ..... 3-18
- Indicator and warning lights ..... 3-2

## K

- Key identification number ..... 9-1

## L

- License plate light bulb, replacing ..... 6-36

## M

- Main switch/steering lock ..... 3-1
- Matte color, caution ..... 7-1
- Model label ..... 9-2
- Multi-function display ..... 3-3

## N

- Neutral indicator light ..... 3-2

## P

- Panels, removing and installing ..... 6-6

- Parking ..... 5-4
- Part locations ..... 2-1
- Periodic maintenance and lubrication  
chart ..... 6-2
- Pre-operation check list ..... 4-2

## R

- Rear brake light switch, adjusting ..... 6-22
- Rear suspension, lubricating ..... 6-29

## S

- Safety information ..... 1-1
- Seat ..... 3-12
- Shifting ..... 5-2
- Shift pedal ..... 3-10
- Shock absorber assembly, adjusting ..... 3-15
- Sidestand ..... 3-18
- Sidestand, checking and lubricating ..... 6-29
- Spark plug, checking ..... 6-8
- Specifications ..... 8-1
- Starting the engine ..... 5-1
- Start switch ..... 3-9
- Steering, checking ..... 6-30
- Storage ..... 7-3
- Supporting the motorcycle ..... 6-37

## T

- Tail/brake light ..... 6-35
- Throttle cable free play, checking ..... 6-18
- Throttle grip and cable, checking and  
lubricating ..... 6-27
- Tires ..... 6-18
- Tool kit ..... 6-1
- Troubleshooting ..... 6-40
- Troubleshooting charts ..... 6-41
- Turn signal indicator light ..... 3-2
- Turn signal light bulb, replacing ..... 6-35

Turn signal switch .....3-9

## **V**

Valve clearance .....6-18

Vehicle identification number .....9-1

## **W**

Wheel bearings, checking .....6-31

Wheel (front) .....6-37

Wheel (rear).....6-38

Wheels.....6-20







YAMAHA MOTOR CO., LTD.

PRINTED ON RECYCLED PAPER

PRINTED IN JAPAN

2007.11-0.2x1 

(E)