



OWNER'S MANUAL

Majesty

YP250

5GM-28199-E0

Welcome to the Yamaha world of motorcycling!

As the owner of a YP250, you are benefiting from Yamaha's vast experience in and newest technology for the design and the manufacture of high-quality products, which have earned Yamaha a reputation for dependability.

Please take the time to read this manual thoroughly, so as to enjoy all your YP250's advantages. The owner's manual does not only instruct you in how to operate, inspect and maintain your scooter, but also in how to safeguard yourself and others from trouble and injury.

In addition, the many tips given in this manual will help to keep your scooter in the best possible condition. If you have any further questions, do not hesitate to contact your Yamaha dealer.

The Yamaha team wishes you many safe and pleasant rides. So, remember to put safety first!

IMPORTANT MANUAL INFORMATION

Particularly important information is distinguished in this manual by the following notations:



The **Safety Alert Symbol** means **ATTENTION! BECOME ALERT! YOUR SAFETY IS INVOLVED!**



Failure to follow **WARNING** instructions could result in severe injury or death to the scooter operator, a bystander or a person inspecting or repairing the scooter.

CAUTION:

A **CAUTION** indicates special precautions that must be taken to avoid damage to the scooter.

NOTE:

A **NOTE** provides key information to make procedures easier or clearer.

NOTE:

- This manual should be considered a permanent part of this scooter and should remain with it even if the scooter is subsequently sold.
 - Yamaha continually seeks advancements in product design and quality. Therefore, while this manual contains the most current product information available at the time of printing, there may be minor discrepancies between your scooter and this manual. If there is any question concerning this manual, please consult your Yamaha dealer.
-

IMPORTANT MANUAL INFORMATION

EW000002

⚠ WARNING

PLEASE READ THIS MANUAL CAREFULLY AND COMPLETELY BEFORE OPERATING THIS SCOOTER.

EAU00008

YP250

OWNER'S MANUAL

©1999 by Yamaha Motor Co., Ltd.

1st Edition, October 1999

**All rights reserved. Any reprinting or
unauthorized use without the written
permission of Yamaha Motor Co., Ltd.
is expressly prohibited.**

Printed in Japan

TABLE OF CONTENTS

1 GIVE SAFETY THE RIGHT OF WAY

1

2 DESCRIPTION

2

3 INSTRUMENT AND CONTROL FUNCTIONS

3

4 PRE-OPERATION CHECKS

4

5 OPERATION AND IMPORTANT RIDING POINTS

5

6 PERIODIC MAINTENANCE AND MINOR REPAIR

6

7 SCOOTER CARE AND STORAGE

7

8 SPECIFICATIONS

8

9 CONSUMER INFORMATION

9

INDEX



GIVE SAFETY THE RIGHT OF WAY

GIVE SAFETY THE RIGHT OF WAY	1-1
FURTHER SAFE RIDING POINTS FOR THIS MODEL	1-2



GIVE SAFETY THE RIGHT OF WAY

1

Scooters are fascinating vehicles, which can give you an unsurpassed feeling of power and freedom. However, they also impose certain limits, which you must accept; even the best scooter does not ignore the laws of physics.

Regular care and maintenance are essential for preserving your scooter's value and operating condition. Moreover, what is true for the scooter is also true for the rider: good performance depends on being in good shape. Riding under the influence of medication, drugs and alcohol is, of course, out of the question. Scooter riders more than car drivers must always be at their mental and physical best. Under the influence of even small amounts of alcohol, there is a tendency to take dangerous risks.

Protective clothing is as essential for the scooter rider as seat belts are for car drivers and passengers. Always wear a complete motorcycle suit (whether made of leather or tear-resistant synthetic materials with protectors), sturdy boots, motorcycle gloves and a properly fitting helmet. Optimum protective wear, however, should not encourage carelessness. Though full-coverage helmets and suits, in particular, create an illusion of total safety and protection, motorcyclists will always be vulnerable. Riders who lack critical self-control run the risk of going too fast and are apt to take chances. This is even more dangerous in wet weather. The good motorcyclist rides safely, predictably and defensively avoiding all dangers, including those caused by others.

Enjoy your ride!



FURTHER SAFE RIDING POINTS FOR THIS MODEL

- Be sure to signal clearly when making turns.
- Braking can be extremely difficult on a wet road. Avoid hard braking, because the scooter could slide. Apply the brakes slowly when stopping on a wet surface.
- Slow down as you approach a corner or turn. Once you have completed a turn, accelerate slowly.
- Be careful when passing parked cars. A driver might not see you and open a door in your path.
- Street car rails, iron plates on road construction sites, and man-hole covers become extremely slippery when wet. Slow down and cross them with caution. Keep the scooter upright. It could slide out from under you.
- The brake pads could get wet when you wash the scooter. After washing the scooter, check the brakes before riding.
- Always wear a helmet, gloves, trousers (tapered around the cuff and ankle so they do not flap), and a bright colored jacket.
- Do not carry too much luggage on the scooter. An overloaded scooter is unstable.

Left view	2-1
Right view	2-2
Controls/Instruments	2-3

DESCRIPTION

Left view

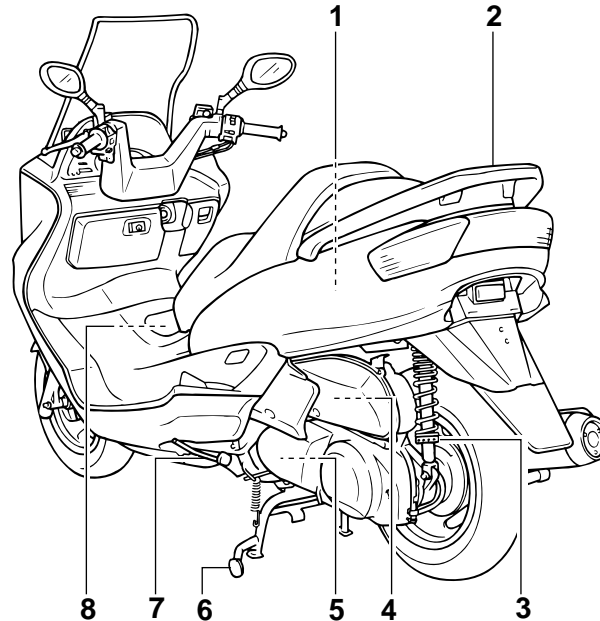

- | | | | |
|---------------------------------------------------------|-------------|---------------------------|-------------|
| 1. Rear storage compartment | (page 3-14) | 5. V-belt case air filter | (page 6-17) |
| 2. Grab bar | (Page 5-2) | 6. Centerstand | (page 6-24) |
| 3. Rear shock absorber spring preload
adjusting ring | (page 3-15) | 7. Sidestand | (page 3-16) |
| 4. Air filter | (page 6-16) | 8. Fuel tank cap | (page 3-10) |

Right view

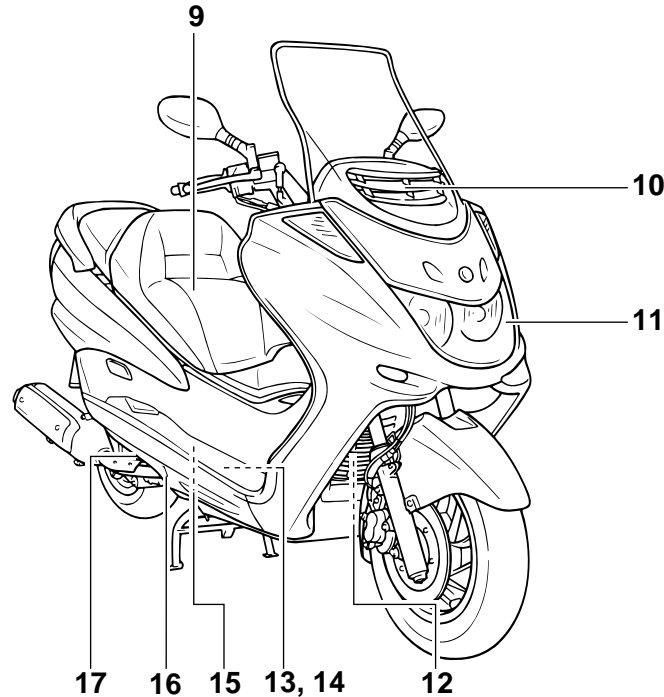

- | | | | |
|---------------------|-------------|--------------------------------|-------------|
| 9. Rider seat | (page 3-12) | 14. Fuse box | (page 6-27) |
| 10. Air flow louver | (page 6-18) | 15. Coolant reservoir tank | (page 6-15) |
| 11. Headlight | (page 6-28) | 16. Coolant level check window | (page 6-15) |
| 12. Radiator | | 17. Engine oil dipstick | (page 6-11) |
| 13. Battery | (page 6-26) | | |

DESCRIPTION

Controls/Instruments

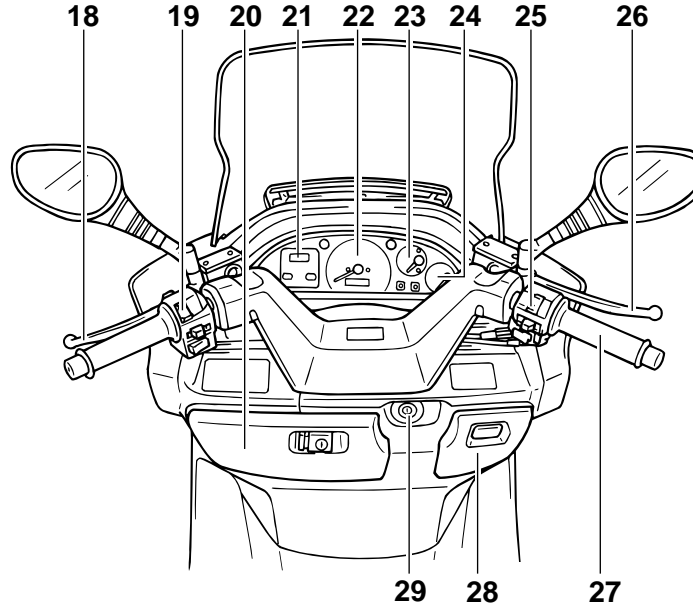

- | | | | |
|---------------------------------|-----------------|---------------------------------|-----------------|
| 18. Rear brake lever | (page 3-10) | 24. Fuel gauge | (page 3-5) |
| 19. Left handlebar switches | (page 3-6, 3-7) | 25. Right handlebar switches | (page 3-7, 3-9) |
| 20. Front storage compartment A | (page 3-14) | 26. Front brake lever | (page 3-9) |
| 21. Digital clock | (page 3-6) | 27. Throttle grip | |
| 22. Speedometer | (page 3-4) | 28. Front storage compartment B | (page 3-14) |
| 23. Coolant temperature gauge | (page 3-5) | 29. Main switch/steering lock | (page 3-1) |

INSTRUMENT AND CONTROL FUNCTIONS

Main switch/steering lock.....	3-1
Indicator lights	3-2
Oil change indicator light circuit check	3-3
Speedometer	3-4
Diagnosis device	3-4
Antitheft alarm (optional)	3-5
Fuel gauge.....	3-5
Coolant temperature gauge.....	3-5
Digital clock	3-6
Handlebar switches	3-6
Headlight beam variation.....	3-8
Front brake lever	3-9
Rear brake lever	3-10
Fuel tank cap	3-10
Fuel.....	3-11
Catalyzer	3-12
Rider seat	3-12
Rider seat adjustment.....	3-13
Storage compartments	3-14
Rear shock absorber adjustment.....	3-15
Carrier (optional).....	3-16
Sidestand.....	3-16
Sidestand switch operation check	3-17

INSTRUMENT AND CONTROL FUNCTIONS

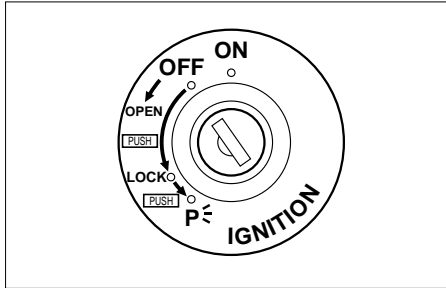

EAU00040

EAU01433

LOCK

The steering is locked in this position and all electrical circuits are switched off. The key can be removed in this position.

To lock the steering, turn the handlebars all the way to the left. While pushing the key into the main switch, turn it from “OFF” to “LOCK” and remove it.

To release the lock, turn the key to “OFF” while pushing.

EW000016

▲WARNING

Never turn the key to “OFF” or “LOCK” when the scooter is moving. The electrical circuits will be switched off which may result in loss of control or an accident. Be sure the scooter is stopped before turning the key to “OFF” or “LOCK”.

P (Parking)

The steering is locked in this position, and the taillight, license light and auxiliary light come on, but all other circuits are off. The key can be removed in this position.

To set the main switch to “P”:

1. Set the main switch to “LOCK”.
2. Slightly turn the key counterclockwise until it stops.
3. While still turning the key counterclockwise, push it inward until it snaps into place.

Do not leave the main switch in this position for an extended period of time because the battery may discharge.

EAU00029

Main switch/steering lock

The main switch controls the ignition and lighting systems. Its operation is described below.

EAU00036

ON

Electrical circuits are switched on. The engine can be started. The key cannot be removed in this position.

EAU00038

OFF

All electrical circuits are switched off. The key can be removed in this position.

INSTRUMENT AND CONTROL FUNCTIONS

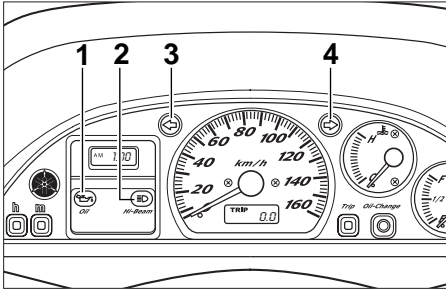

1. Oil change indicator light “”
2. High beam indicator light “”
3. Left turn indicator light “”
4. Right turn indicator light “”

EAU00056

Indicator lights

EAU00078

Oil change indicator light “”

When this indicator light comes on, the engine oil should be changed. It will come on at the initial 1,000 km and every 3,000 km thereafter. (Refer to “Engine oil replacement” for resetting procedures.)

The oil change indicator light circuit can be checked by the procedure on page 3-3.

EAU00063

High beam indicator light “”

This indicator comes on when the headlight high beam is used.

EAU03125*

Turn indicator lights “”/“”

The corresponding indicator flashes when the turn signal switch is moved to the left or right.

INSTRUMENT AND CONTROL FUNCTIONS

EAU00076

Oil change indicator light circuit check

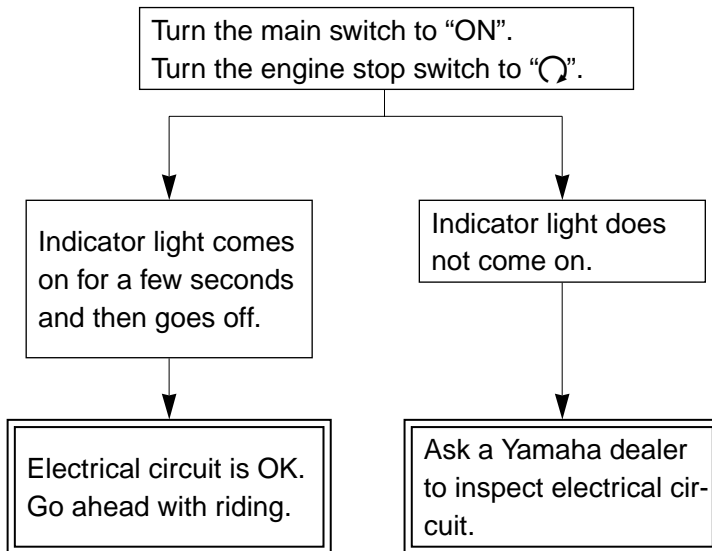

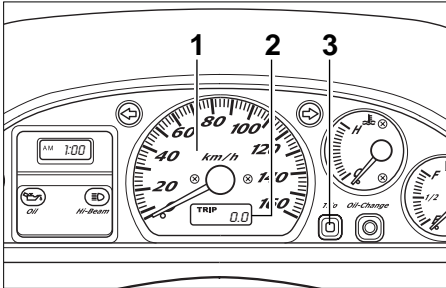

1. Speedometer
2. Digital odometer/trip odometer
3. Reset button

EAU01586

Speedometer

The speedometer shows riding speed. This speedometer is equipped with a digital odometer and a trip odometer.

Pushing the “TRIP” reset button will change the display from one to the other.

When set to “ODO”, the display indicates the scooter’s total mileage.

When set to “TRIP”, the display indicates the scooter’s mileage since the trip odometer was last reset.

Use the trip meter together with the fuel gauge to estimate how far you can ride on a tank of fuel. This information will enable you to plan fuel stops in the future.

To reset the trip odometer to “0.0”, set the display to the “TRIP” mode. Then, push the “TRIP” reset button for at least one second.

Diagnosis device

This model is equipped with a diagnosis device for the oil change indicator light circuit and the speedometer. If some trouble should occur in the circuit or the speedometer, the oil change indicator light will flash. In this case, take your scooter to a Yamaha dealer for repair.

NOTE: _____

The oil change indicator light may flash when accelerating the engine while the scooter is on its center-stand, but this is normal.

INSTRUMENT AND CONTROL FUNCTIONS

Antitheft alarm (optional)

An antitheft alarm can be equipped to this scooter. Consult your Yamaha dealer to obtain and install the alarm.

EAU00109

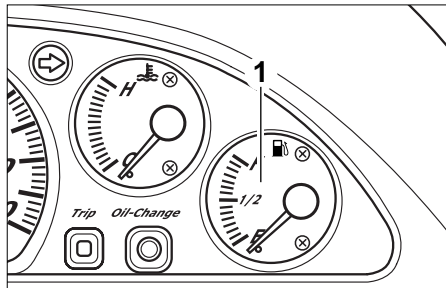

1. Fuel gauge

EAU00110

Fuel gauge

This model is equipped with an electric fuel gauge so the rider can monitor the fuel level in the fuel tank. When the needle indicates "E" (Empty), about 1.0 L remain in the fuel tank.

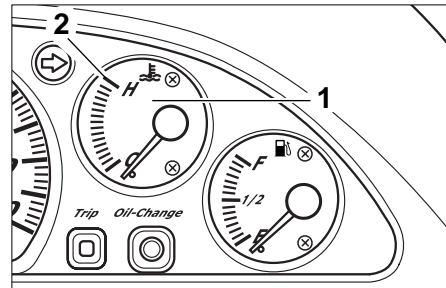

1. Coolant temperature gauge
2. Red mark

EAU03124*

Coolant temperature gauge

This gauge indicates the coolant temperature when the main switch is on. The engine operating temperature will vary with changes in weather and engine load. If the needle points to the red mark, stop your scooter and let the engine cool. (See page 6-15 for details.)

EC000002

CAUTION:

When the engine is overheated, do not continue riding.

INSTRUMENT AND CONTROL FUNCTIONS

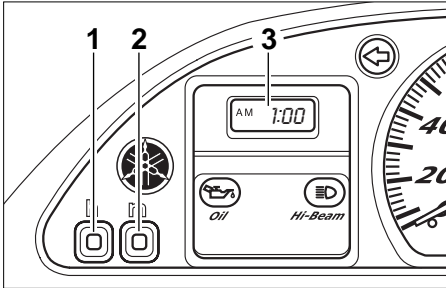

1. Hour button “h”
2. Minute button “m”
3. Digital clock

EAU03089*

Digital clock

This digital clock shows the time regardless of the main switch position.

To set the clock

1. Turn the key to “ON”.
2. The time (hour) setting can be made by pushing or holding the “h” button.
3. The time (minute) setting can be made by pushing or holding the “m” button.

NOTE: _____
When setting the clock after its power source is cut by a removed battery, etc., or when pushing the “h” and “m” button simultaneously, first set the time for 1:00 AM, then, go on to set it for the correct time.

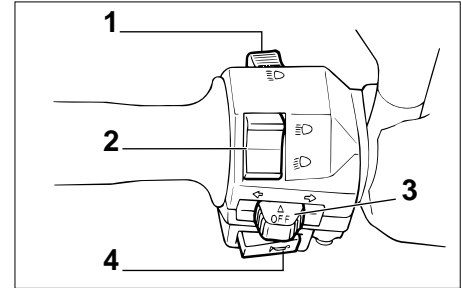

1. Pass switch “≡D”
2. Dimmer switch
3. Turn signal switch
4. Horn switch “𐀀”

EAU00118

Handlebar switches

EAU00119

Pass switch “≡D”

Press the switch to operate the passing light.



EAU00121

Dimmer switch

Turn the switch to “≡D” for the high beam and to “𐀀D” for the low beam.

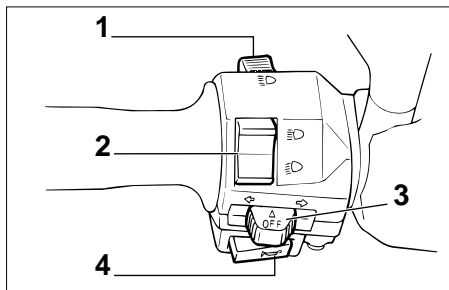

INSTRUMENT AND CONTROL FUNCTIONS



1. Pass switch “”
2. Dimmer switch
3. Turn signal switch
4. Horn switch “”

EAU00127

Turn signal switch

To signal a right-hand turn, push the switch to “”. To signal a left-hand turn, push the switch to “”. Once the switch is released it will return to the center position. To cancel the signal, push the switch in after it has returned to the center position.

EAU00129

Horn switch “”

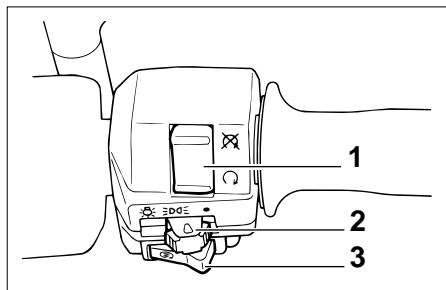

Press the switch to sound the horn.



1. Engine stop switch
2. Light switch
3. Start switch “”

EAU00135

Light switch

Turning the light switch to “” turns on the auxiliary light, meter lights, taillight and licence light. Turning the light switch to “” turns the headlight on also.

INSTRUMENT AND CONTROL FUNCTIONS

EAU00136









Headlight beam variation

☀ : High beam light on

☀ : Low beam light on

☾☾☾ : Auxiliary light on

○ : Light off

		Left	Right	Aux	Bulb to be used		Destination
1		☀	○	☾☾☾	Halogen bulb	 	Germany, Belgium, Switzerland, Spain France, Greece, Italy, Netherlands, Norway, Portugal, Sweden
		○	☀	☾☾☾			
2		○	☀	☾☾☾	Halogen bulb	 	England
		☀	○	☾☾☾			

3

NOTE:

Right and left directions are those assumed from the position of a person facing the front of the scooter.

INSTRUMENT AND CONTROL FUNCTIONS

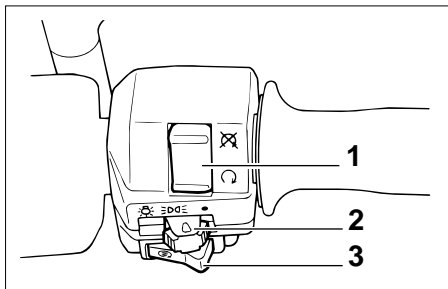

1. Engine stop switch
2. Light switch
3. Start switch “⊚”

EAU00138

Engine stop switch

The engine stop switch is a safety device for use in an emergency such as when the scooter overturns or if trouble occurs in the throttle system. Turn the switch to “⊚” to start the engine.

In case of emergency, turn the switch to “⊗” to stop the engine.

EAU00143

Start switch “⊚”

The starter motor cranks the engine when pushing the start switch.

EC000005

CAUTION:

See starting instructions prior to starting the engine.

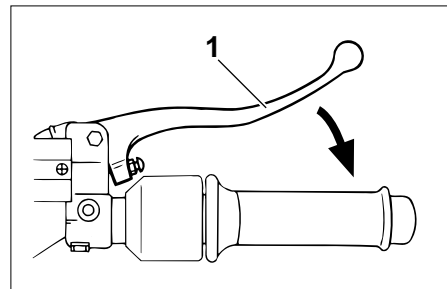

1. Front brake lever

EAU00158

Front brake lever

The front brake lever is located on the right handlebar. Pull it toward the handlebar to apply the front brake.

INSTRUMENT AND CONTROL FUNCTIONS

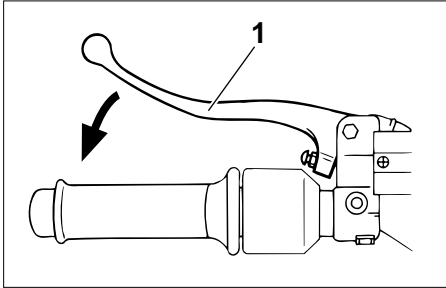

1. Rear brake lever

EAU00163

Rear brake lever

The rear brake lever is located on the left handlebar. Pull it toward the handlebar to apply the rear brake.

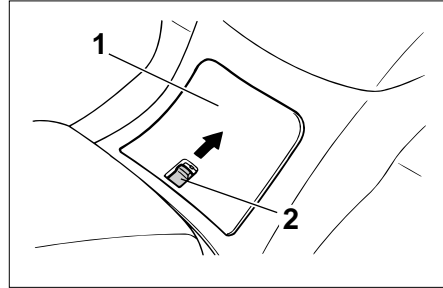

1. Lid
2. Lever

EAU03090*

Fuel tank cap

The fuel tank cap is located under the lid in front of the seat.

To open the lid, slide the lever forward and then pull the lever up.

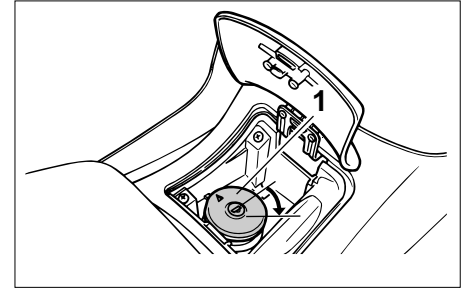

1. Fuel tank cap

To open the fuel tank cap, insert the key into the lock and turn it clockwise.

INSTRUMENT AND CONTROL FUNCTIONS

EAU00185

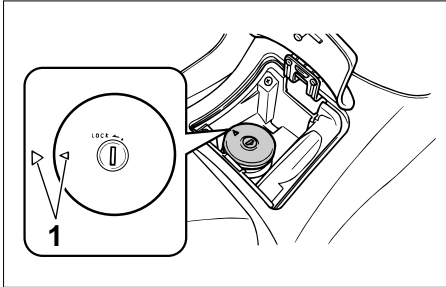

1. Match marks

To close the cap, align the match marks and push down on the cap. Then, turn the key to the original position and remove it. Close the lid.

EWA00028*

⚠WARNING

Be sure the cap is properly installed and locked in place before riding the scooter.

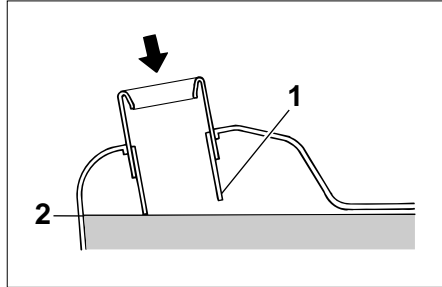

1. Filler tube
2. Fuel level

EAU01183

Fuel

Make sure there is sufficient fuel in the tank. Fill the fuel tank to the bottom of the filler tube as shown in the illustration.

EW000130

⚠WARNING

Do not overfill the fuel tank. Avoid spilling fuel on the hot engine. Do not fill the fuel tank above the bottom of the filler tube or it may overflow when the fuel heats up later and expands.

CAUTION:

Always wipe off spilled fuel immediately with a dry and clean soft cloth. Fuel may deteriorate painted surfaces or plastic parts.

EAU00191*

Recommended fuel:

Regular unleaded gasoline
with a research octane
number of 91 or higher.

Fuel tank capacity:

Total amount:
12 L

NOTE:

If knocking or pinging occurs, use a different brand of gasoline or higher octane grade.

Catalyzer

This scooter is equipped with a catalytic converter in the muffler.

EAU03098*

EC000114

CAUTION:

The following must be observed to prevent a fire hazard or other damages.

- Use only unleaded gasoline. Use of leaded gasoline will cause unreparable damage to the catalytic converter.
- Never park this scooter in an area that would cause a fire hazard such as grass or other materials that may easily burn.
- Do not allow the engine to idle for very long.

WARNING

EW000128

The exhaust system is hot during and directly after engine operation. Make sure the exhaust system has cooled down before making any adjustment to or lubricating the scooter.

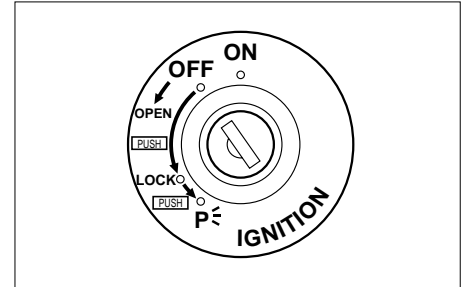

3

EAU03091*

Rider seat

To open

Insert the key into the main switch and turn it counterclockwise. Do not push inward when turning the key.

To close

Push the rider seat downward to the original position and remove the key from the main switch.

INSTRUMENT AND CONTROL FUNCTIONS

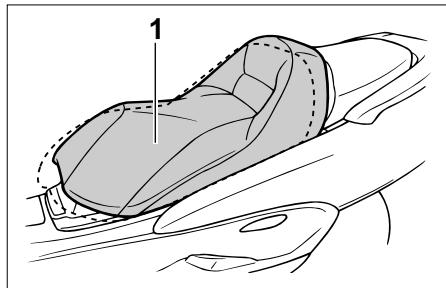
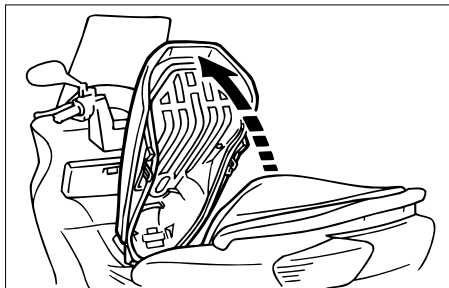

1. Rider seat

EAU03096*

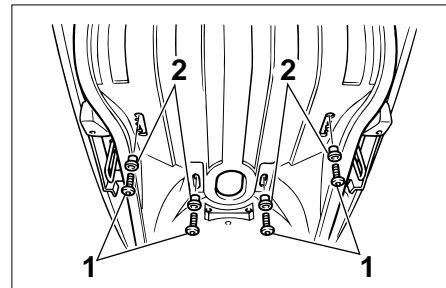

1. Bolt (x4)
2. Collar (x4)

NOTE:

- Place the scooter on the center-stand before opening the rider seat.
- Make sure the rider seat is securely closed before riding the scooter.

Rider seat adjustment

The rider seat can be adjusted to change the riding position.

To adjust, open the rider seat and remove the bolts and collars. Slide the seat forward or backward to the desired position. Install the collars and tighten the bolts securely. Then close the seat.

INSTRUMENT AND CONTROL FUNCTIONS

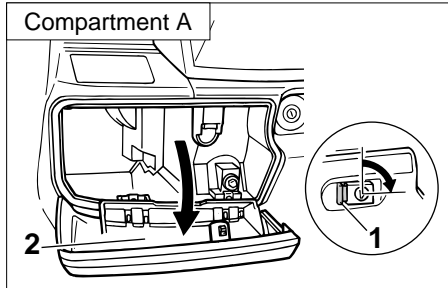

1. Button
2. Lid

EAU03110*

Storage compartments

Front storage compartment A

To open the storage compartment when it is locked, insert the key, turn it counterclockwise, grasp the lock while pushing the button in.

To open the storage compartment when it is unlocked, simply grasp the lock while pushing the button in.

To lock the storage compartment, push the lid into the original position. Insert the key and turn it clockwise. Then remove the key.

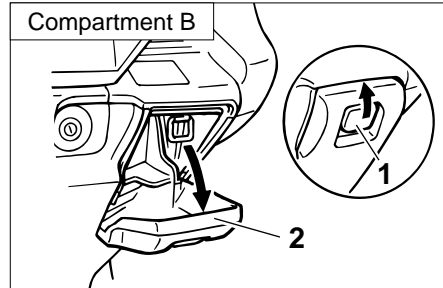

1. Lever
2. Lid

Front storage compartment B

To open the storage compartment, slide the lever up and pull on the lever.

To close the storage compartment, push the lid into the original position.

EWA00029*

⚠ WARNING

Do not store heavy items in this compartment.

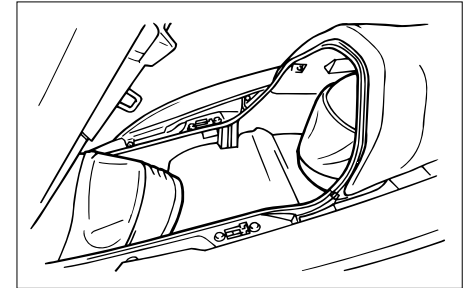

3

Rear storage compartment

Two helmets can be stored in the compartment under the seats. When the rider seat is opened, the compartment light will come on. (See page 3-12 for rider seat opening and closing procedures.)

INSTRUMENT AND CONTROL FUNCTIONS

CAUTION:

ECA00051*

Do not leave the rider seat open for an extended period of time as the light may cause the battery to discharge.

WARNING

EWA00030*

Do not exceed the loading limits:
Front storage compartment A: 2 kg
Rear storage compartment: 5 kg

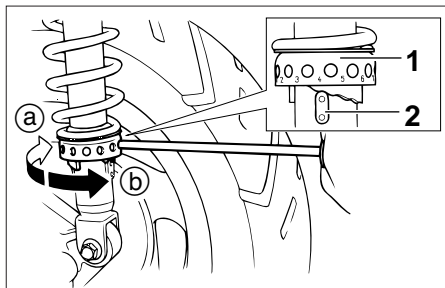

1. Spring preload adjusting ring
2. Position indicator

EAU00300

Rear shock absorber adjustment

Each shock absorber is equipped with a spring preload adjusting ring. Adjust spring preload as follows.

Turn the adjusting ring in direction (a) to increase spring preload and in direction (b) to decrease spring preload. Make sure that the appropriate notch in the adjusting ring is aligned with the position indicator on the rear shock absorber.

Adjusting Position	Soft			Standard	Hard		
	1	2	3	4	5	6	7

EW000040

WARNING

Always adjust each shock absorber to the same setting. Uneven adjustment can cause poor handling and loss of stability.

EAU03092*

Carrier (optional)

An optional carrier can be obtained and installed at a Yamaha dealer for adding cargo or accessories to this scooter.

EAU00330

Sidestand

This model is equipped with an ignition circuit cut-off system. The scooter must not be ridden when the sidestand is down. The sidestand is located on the left side of the frame. (Refer to page 3-17 for an explanation of this system.)

EW000044

▲WARNING

This scooter must not be operated with the sidestand in the down position. If the stand is not properly retracted, it could contact the ground and distract the operator, resulting in a possible loss of control. Yamaha has designed into this scooter a lockout system to assist the operator in fulfilling the responsibility of retracting the sidestand. Please check carefully the operating instructions listed below and if there is any indication of a malfunction, return the scooter to a Yamaha dealer immediately for repair.

INSTRUMENT AND CONTROL FUNCTIONS

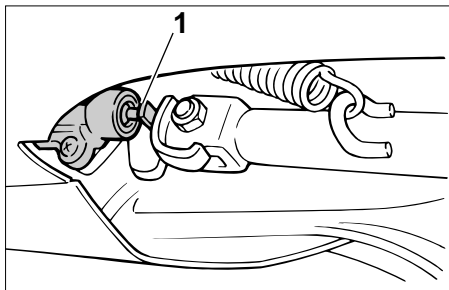

1. Sidestand switch

EAU00337

Sidestand switch operation check

Check the operation of the sidestand switch against the information below.

EW000046

⚠ WARNING

- Be sure to use the centerstand during this inspection.
- If improper operation is noted, consult a Yamaha dealer.

Turn the main switch to "ON" and the engine stop switch to "O".



Put the sidestand up.



Push the start switch while applying either of the brake levers.
The engine will start.



Put the sidestand down.



If the engine stalls:



The sidestand switch is OK.

EW000045

⚠ WARNING

If improper operation is noted, consult a Yamaha dealer immediately.

Pre-operation check list4-1

PRE-OPERATION CHECKS

Owners are personally responsible for their vehicle's condition. Your scooter's vital functions can start to deteriorate quickly and unexpectedly, even if it remains unused (for instance, if it is exposed to the elements). Any damage, fluid leak or loss of tire pressure could have serious consequences. Therefore, it is very important that, in addition to a thorough visual inspection, you check the following points before each ride.

EAU00340

PRE-OPERATION CHECK LIST

ITEM	CHECKS	PAGE
Front brake	<ul style="list-style-type: none"> • Check operation, free play, fluid level and vehicle for fluid leakage. • Fill with DOT 4 brake fluid if necessary. 	3-9, 6-20 ~ 6-23
Rear brake	<ul style="list-style-type: none"> • Check operation, free play, fluid level and vehicle for fluid leakage. • Fill with DOT 4 brake fluid if necessary. 	3-10, 6-20 ~ 6-23
Engine oil	<ul style="list-style-type: none"> • Check oil level • Fill with oil if necessary. 	6-11 ~ 6-13
Final gear oil	<ul style="list-style-type: none"> • Check vehicle for leakage. 	6-14
Throttle grip and housing	<ul style="list-style-type: none"> • Check for smooth operation. • Lubricate if necessary. 	—
Wheels and tires	<ul style="list-style-type: none"> • Check tire pressure, wear and damage. 	6-18 ~ 6-20
Chassis fasteners	<ul style="list-style-type: none"> • Make sure that all nuts, bolts, and screws are properly tightened. • Tighten if necessary. 	—
Lights, signals and switches	<ul style="list-style-type: none"> • Check for proper operation. 	3-6 ~ 3-9, 6-28 ~ 6-32

NOTE:

Pre-operation checks should be made each time the scooter is used. Such an inspection can be accomplished in a very short time; and the added safety it assures is more than worth the time involved.

⚠ WARNING

If any item in the Pre-Operation Check is not working properly, have it inspected and repaired before operating the scooter.

OPERATION AND IMPORTANT RIDING POINTS

Starting a cold engine.....	5-1
Starting off	5-2
Acceleration.....	5-2
Braking	5-2
Tips for reducing fuel consumption.....	5-3
Engine break-in	5-3
Parking	5-4

OPERATION AND IMPORTANT RIDING POINTS

⚠ WARNING

EAU01118

1. Before riding this scooter, become thoroughly familiar with all operating controls and their functions. Consult a Yamaha dealer regarding any control or function that you do not thoroughly understand.
2. Never start your engine or let it run for any length of time in a closed area. The exhaust fumes are poisonous and can cause loss of consciousness and death within a short time. Always operate your scooter in an area with adequate ventilation.
3. For safety, be sure to start the engine with the centerstand down.

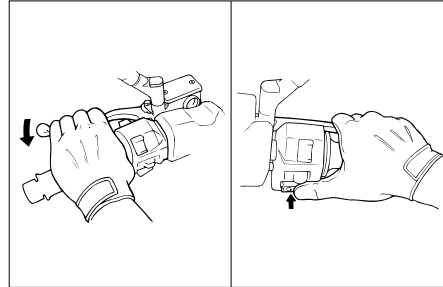

EAU00419

Starting a cold engine

NOTE: This scooter is equipped with an ignition circuit cut-off switch. The scooter must not be ridden with the sidestand down.

1. Turn the main switch to “ON” and the engine stop switch to “O”.
2. Completely close the throttle grip.
3. Apply either brake and push the start switch to start the engine.

NOTE: _____

- If the engine fails to start, release the start switch, wait a few seconds, then try again. Each attempt should be as short as possible to preserve the battery. Do not crank the engine more than 10 seconds on any one attempt.
- For maximum engine life, never accelerate hard with a cold engine!

OPERATION AND IMPORTANT RIDING POINTS

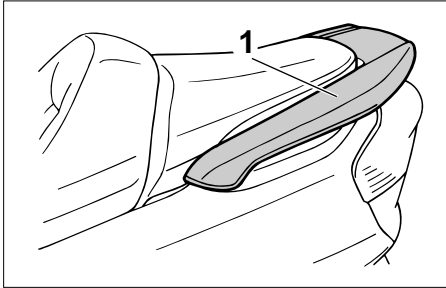

1. Grab bar

EAU00433

Starting off

After warming up the engine:

1. Apply the rear brake lever with your left hand and hold the grab bar with your right hand. Then push the scooter off the center-stand.
2. Sit astride the seat and adjust the rear view mirrors.
3. Check the oncoming traffic and use a turn signal.
4. Turn the throttle grip on the right handlebar slowly and you will start off. Remember to turn off the turn signal.

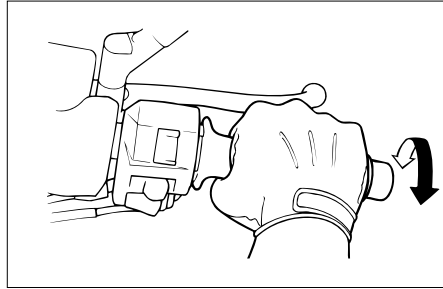

EAU00434

Acceleration

The speed can be adjusted by opening and closing the throttle grip. Turning it toward you increases the speed, and turning it in the opposite direction decreases the speed.

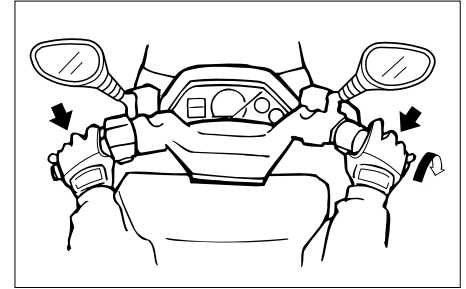

EAU00435

Braking

1. Close the throttle grip.
2. Apply both front and rear brakes simultaneously with light pressure and increase the pressure slowly.

⚠️ WARNING

EW000057

EAU03093*

EAU01128

- **Avoid hard or sudden braking. It may cause the scooter to skid or overturn.**
 - **Be sure to apply the brake carefully if leaning over to one side. Improper braking could lead to a skid.**
 - **Street car rails, metal plates on road construction sites, and man-hole covers become particularly slippery when they get wet. Cross them slowly and cautiously.**
 - **Braking on a wet road is very difficult.**
 - **Braking on a hill can be difficult. Proceed slowly when riding downhill.**
-

Tips for reducing fuel consumption

Your scooter's fuel consumption depends to a large extent on your riding style. The following tips can help reduce fuel consumption:

- Warm up the engine before riding.
- Avoid high engine speeds during acceleration.
- Avoid high engine speeds with no load on the engine.
- Turn off the engine instead of letting it idle for an extended length of time, i.e. in traffic jams, at traffic lights or railroad crossings.

Engine break-in

There is never a more important period in the life of your scooter than the period between zero and 1,600 km. For this reason we ask that you carefully read the following material. Because the engine is brand new, you must not put an excessive load on it for the first 1,600 km. The various parts in the engine wear and polish themselves to the correct operating clearances. During this period, prolonged full throttle operation, or any condition which might result in excessive heating of the engine, must be avoided.

OPERATION AND IMPORTANT RIDING POINTS

0 ~ 1,000 km

Avoid operation above 1/3 throttle.

EAU03123*

1,000 ~ 1,600 km

Avoid cruising speeds in excess of 1/2 throttle.

ECA00054*

CAUTION:

After 1,000 km of operation, be sure to replace the engine oil and final gear oil.

1,600 km and beyond

Proceed with normal riding.

EC000049

CAUTION:

If any engine trouble should occur during the break-in period, consult a Yamaha dealer immediately.

Parking

When parking the scooter, stop the engine and remove the ignition key.

EAU00461

EW000059

WARNING

The muffler and exhaust pipe are hot. Park the scooter in a place where pedestrians or children are not likely to touch the scooter. Do not park the scooter on a slope or soft ground; the scooter may overturn.

EC000062

CAUTION:

Never park this scooter in an area that would cause a fire hazard such as grass or other materials that may easily burn.

PERIODIC MAINTENANCE AND MINOR REPAIR

Tool kit	6-1	Battery cover removal	6-26
Periodic maintenance and lubrication	6-3	Battery.....	6-26
Panel removal and installation	6-6	Fuse replacement	6-27
Panel A	6-6	Headlight bulb replacement	6-28
Panel B	6-8	Tail/brake light bulb replacement	6-30
Panel C	6-8	Front turn signal light bulb replacement.....	6-30
Spark plug.....	6-10	Rear turn signal light bulb replacement	6-31
Engine oil	6-11	License light bulb replacement	6-32
Final gear oil replacement.....	6-14	Troubleshooting	6-33
Coolant.....	6-15	Troubleshooting chart	6-34
Air filter and V-belt case filter cleaning.....	6-16		
Air flow louver	6-18		
Tires	6-18		
Wheels	6-20		
Brake lever free play adjustment	6-20		
Checking the front and rear brake pads.....	6-21		
Inspecting the brake fluid level.....	6-22		
Brake fluid replacement	6-23		
Cable inspection and lubrication	6-23		
Brake lever lubrication	6-23		
Center and sidestand lubrication	6-24		
Front fork inspection	6-24		
Steering inspection	6-25		
Wheel bearings	6-25		

PERIODIC MAINTENANCE AND MINOR REPAIR

EAU00464

Periodic inspection, adjustment and lubrication will keep your scooter in the safest and most efficient condition possible. Safety is an obligation of the scooter owner. The maintenance and lubrication schedule chart should be considered strictly as a guide to general maintenance and lubrication intervals.

YOU MUST TAKE INTO CONSIDERATION THAT WEATHER, TERRAIN, GEOGRAPHICAL LOCATIONS, AND A VARIETY OF INDIVIDUAL USES ALL TEND TO DEMAND THAT EACH OWNER ALTER THIS TIME SCHEDULE TO SHORTER INTERVALS TO MATCH THE ENVIRONMENT. The most important points of scooter inspection, adjustment, and lubrication are explained in the following pages.

EW00060

⚠ WARNING

If you are not familiar with scooter service, this work should be done by a Yamaha dealer.

EAU00466

⚠ WARNING

This scooter is designed for use on paved road surface only. If this scooter is operated in abnormally dusty, muddy or wet conditions, the air filter should be cleaned or replaced more frequently. Otherwise, rapid engine wear may result. Consult a Yamaha dealer for proper maintenance intervals.

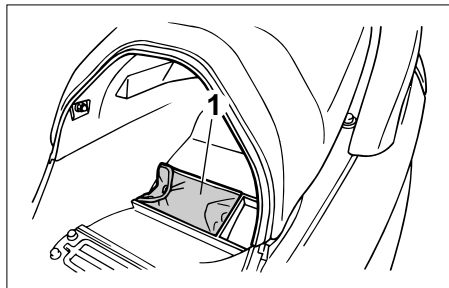

1. Tool kit

EAU01129

Tool kit

The tool kit is located inside of the storage compartment. (See page 3-14 for compartment opening procedures.) The tools provided in the owner's tool kit are to assist you in the performance of periodic maintenance. However, some other tools such as a torque wrench are also necessary to perform the maintenance correctly.

The service information included in this manual is intended to provide you, the owner, with the necessary information for completing some of your own preventive maintenance and minor repairs.

PERIODIC MAINTENANCE AND MINOR REPAIR

NOTE: _____

If you do not have necessary tools required during a service operation, take your scooter to a Yamaha dealer for service.

EW000062

⚠ WARNING _____

Modifications to this scooter not approved by Yamaha may cause loss of performance, excessive emissions, and render it unsafe for use. Consult a Yamaha dealer before attempting any changes.

PERIODIC MAINTENANCE AND MINOR REPAIR

EAU00473

PERIODIC MAINTENANCE AND LUBRICATION

No.	ITEM	CHECKS AND MAINTENANCE JOB	Initial (1,000 km)	EVERY		ANNUAL CHECK
				10,000 km	20,000 km	
1 *	Fuel line	<ul style="list-style-type: none"> • Check fuel hoses and vacuum hose for cracks or damage. • Replace if necessary. 		√		√
2	Fuel filter	<ul style="list-style-type: none"> • Check condition. • Replace if necessary. 			√	
3	Spark plug	<ul style="list-style-type: none"> • Check condition. • Clean, regap or replace if necessary. 		√		
4 *	Valves	<ul style="list-style-type: none"> • Check valve clearance. • Adjust if necessary. 			√	
5	Air filter	<ul style="list-style-type: none"> • Clean or replace if necessary. 		√		
6	V-belt case air filter	<ul style="list-style-type: none"> • Clean or replace if necessary. 		√		
7 *	Front brake	<ul style="list-style-type: none"> • Check operation, fluid level and vehicle for fluid leakage. (See NOTE on page 6-5.) • Correct accordingly. • Replace brake pads if necessary. 	√	√		√
8 *	Rear brake	<ul style="list-style-type: none"> • Check operation, fluid level and vehicle for fluid leakage. (See NOTE on page 6-5.) • Correct accordingly. • Replace brake pads if necessary. 	√	√		√
9 *	Brake hoses	<ul style="list-style-type: none"> • Check for cracks or damage. • Replace if necessary. 		√		√
10 *	Wheels	<ul style="list-style-type: none"> • Check balance, runout and for damage. • Rebalance or replace if necessary. 		√		
11 *	Tires	<ul style="list-style-type: none"> • Check tread depth and for damage. • Replace if necessary. • Check air pressure. • Correct if necessary. 		√		
12 *	Wheel bearings	<ul style="list-style-type: none"> • Check bearing for looseness or damage. • Replace if necessary. 		√		

PERIODIC MAINTENANCE AND MINOR REPAIR

No.	ITEM	CHECKS AND MAINTENANCE JOB	Initial (1,000 km)	EVERY		ANNUAL CHECK
				10,000 km	20,000 km	
13 *	Steering bearings	<ul style="list-style-type: none"> • Check bearing play and steering for roughness. • Correct accordingly. 	√	√		
		<ul style="list-style-type: none"> • Lubricate with lithium soap base grease. 			√	
14 *	Chassis fasteners	<ul style="list-style-type: none"> • Make sure that all nuts, bolts and screws are properly tightened. • Tighten if necessary. 		√		√
15	Sidestand/centerstand	<ul style="list-style-type: none"> • Check operation. • Lubricate and repair if necessary. 		√		√
16 *	Sidestand switch	<ul style="list-style-type: none"> • Check operation. • Replace if necessary. 	√	√		√
17 *	Front fork	<ul style="list-style-type: none"> • Check operation and for oil leakage. • Correct accordingly. 		√		
18 *	Rear shock absorber assemblies	<ul style="list-style-type: none"> • Check operation and shock absorbers for oil leakage. • Replace shock absorber assembly if necessary. 		√		
19 *	Carburetor	<ul style="list-style-type: none"> • Check engine idling speed and starter operation. • Adjust if necessary. 	√	√		√
20	Engine oil	<ul style="list-style-type: none"> • Check oil level and vehicle for oil leakage. • Correct if necessary. • Change. (Warm engine before draining.) 	√	Replace every 3,000 km		
21 *	Engine oil strainer	<ul style="list-style-type: none"> • Clean or replace if necessary. 	√	Clean or replace every 6,000 km		
22 *	Cooling system	<ul style="list-style-type: none"> • Check coolant level and vehicle for coolant leakage. • Correct if necessary. 		√		√
		<ul style="list-style-type: none"> • Change coolant. 			√	
23	Final gear oil	<ul style="list-style-type: none"> • Check oil level and vehicle for oil leakage. • Change oil. 	√	√		
24 *	V-belt	<ul style="list-style-type: none"> • Replace. 			√	

PERIODIC MAINTENANCE AND MINOR REPAIR

No.	ITEM	CHECKS AND MAINTENANCE JOB	Initial (1,000 km)	EVERY		ANNUAL CHECK
				10,000 km	20,000 km	
25	* Front/Rear brake switch	<ul style="list-style-type: none"> • Check operation. • Adjust or replace if necessary. 	√	√		√
26	Moving parts and cables	<ul style="list-style-type: none"> • Lubricate if necessary. 		√		√
27	* Electrical components	<ul style="list-style-type: none"> • Check all lights, signals and switches function. • Correct if necessary. • Adjust headlight beam if necessary. 	√	√		√

* Since these items require special tools, data and technical skills, they should be serviced by a Yamaha dealer.

EAU03206

NOTE:

- The annual checks must be performed every year, except if a 10,000 km or 20,000 km maintenance is performed instead.
- The air filter needs more frequent service if you are riding in unusually wet or dusty areas.
- Hydraulic brake service
 - Regularly check and, if necessary, correct the brake fluid level.
 - Every two years replace the internal components of the brake master cylinder and caliper, and change the brake fluid.
 - Replace the brake hoses every four years and if cracked or damaged.

PERIODIC MAINTENANCE AND MINOR REPAIR

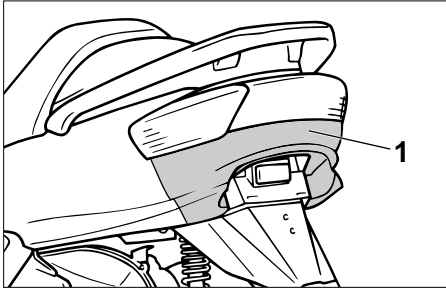

1. Panel A

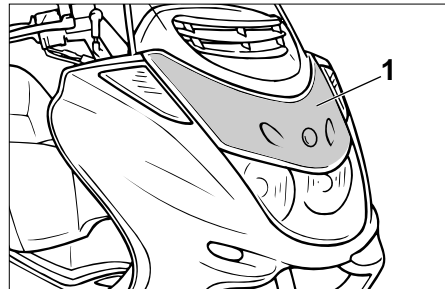

1. Panel B

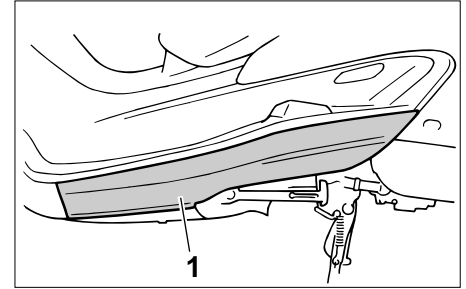

1. Panel C

EAU01122

Panel removal and installation

The panels illustrated need to be removed to perform some of the maintenance described in this chapter.

Refer to this section each time a panel has to be removed or reinstalled.

PERIODIC MAINTENANCE AND MINOR REPAIR

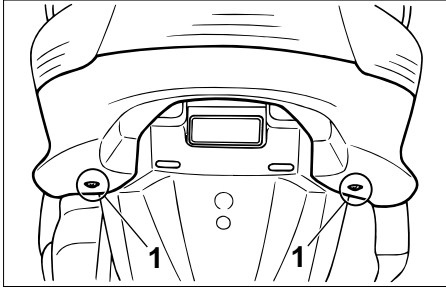

1. Screw (x2)

EAU03114*

Panel A

To remove

1. Remove the screws.

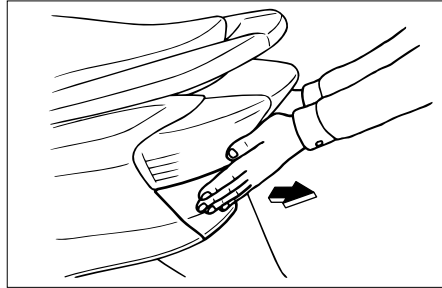

2. Pull the panel back as shown.

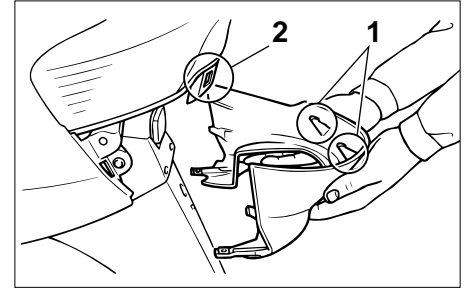

1. Tab (x2)
2. Slot (x2)

To install

1. Insert the tabs on the panel into the slots as shown, and then push the panel in until it snaps into place.
2. Install the screws.

PERIODIC MAINTENANCE AND MINOR REPAIR

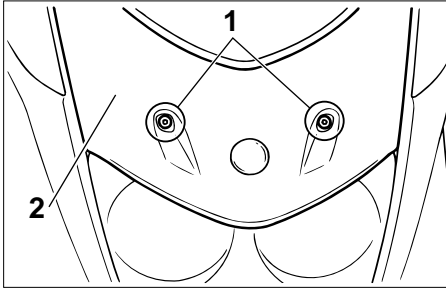

1. Bolt (x2)
2. Panel B

EAU03121*

Panel B

To remove

Remove the bolts, and then pull the panel out as shown.

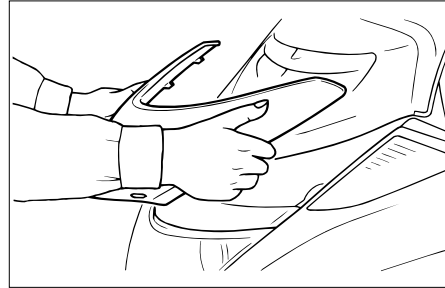

To install

Place the panel in the original position, and then install the bolts.

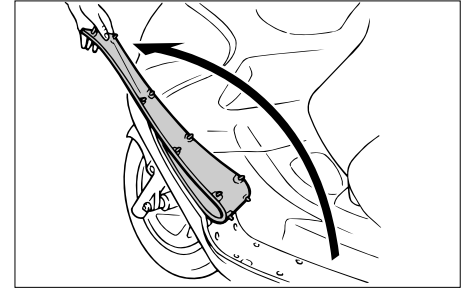

EAU03122*

Panel C

To remove

1. Pull up the left floorboard mat as shown.

PERIODIC MAINTENANCE AND MINOR REPAIR

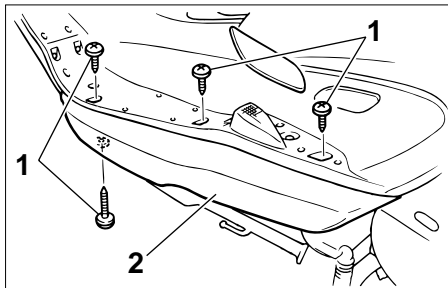

1. Screw (x4)
 2. Panel C
2. Remove the panel screws.

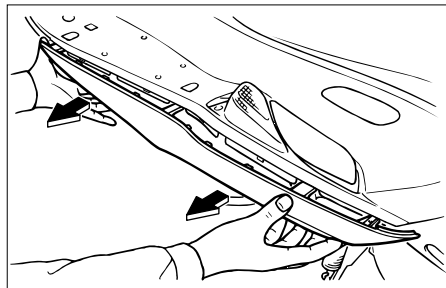

3. Pull the panel out as shown.

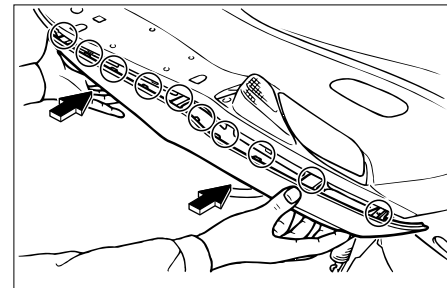

To install

1. Insert the tabs on the panel into the slots as shown.
2. Install the panel screws.

PERIODIC MAINTENANCE AND MINOR REPAIR

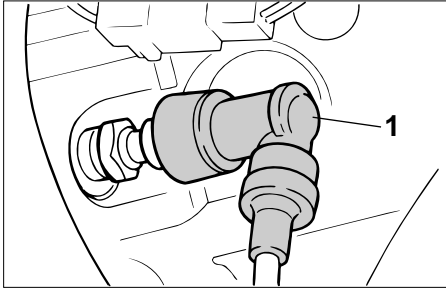

1. Spark plug cap

EAU01833

Spark plug Removal

1. Remove the spark plug cap.

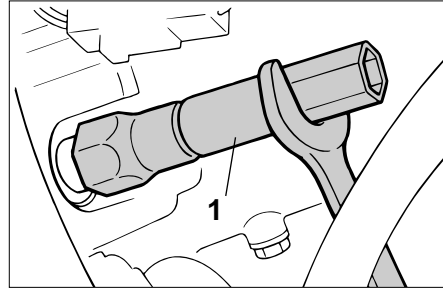

1. Spark plug wrench
2. Use the spark plug wrench in the tool kit to remove the spark plug as shown.

Inspection

The spark plug is an important engine component and is easy to inspect. The condition of the spark plug can indicate the condition of the engine.

The ideal color on the white insulator around the center electrode is a medium-to-light tan color for a scooter that is being ridden normally.

Do not attempt to diagnose such problems yourself. Instead, take the scooter to a Yamaha dealer. You should periodically remove and inspect the spark plug because heat and deposits will cause any spark plug to slowly break down and erode. If electrode erosion becomes excessive, or if carbon and other deposits are excessive, you should replace the spark plug with the specified plug.

Specified spark plug:
DR8EA (NGK)

PERIODIC MAINTENANCE AND MINOR REPAIR

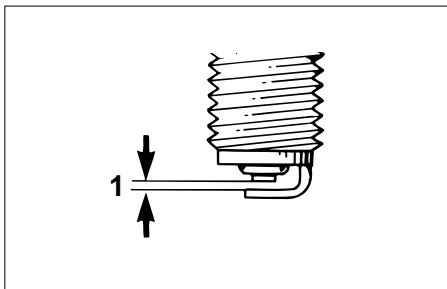

1. Spark plug gap

Installation

1. Measure the electrode gap with a wire thickness gauge and, if necessary, adjust the gap to specification.

Spark plug gap:
0.6 ~ 0.7 mm

2. Clean the gasket surface. Wipe off any grime from the threads.
3. Install the spark plug and tighten it to the specified torque.

Tightening torque:
Spark plug:
17.5 Nm (1.75 m·kg)

NOTE:

If a torque wrench is not available when you are installing a spark plug, a good estimate of the correct torque is 1/4 to 1/2 turn past finger tight. Have the spark plug tightened to the specified torque as soon as possible.

4. Install the spark plug cap.

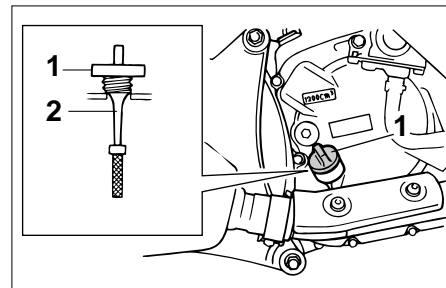

1. Oil filler cap
2. Dipstick

EAU03119*

Engine oil

Oil level measurement

1. Place the scooter on the center-stand. Warm up the engine for several minutes.

NOTE:

- Be sure the scooter is positioned straight up when checking the oil level. A slight tilt toward the side can result in false readings.
- When adding oil, be careful not to overfill the engine; the oil level rises faster starting from the half level portion on the dipstick.

PERIODIC MAINTENANCE AND MINOR REPAIR

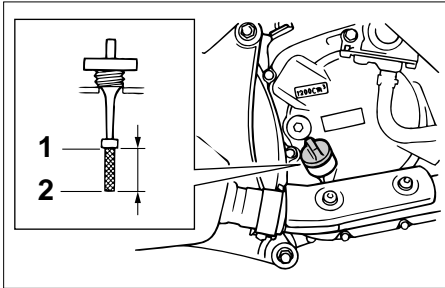

1. Maximum level mark
2. Minimum level mark

2. Stop the engine and remove the oil filler cap.

NOTE: _____

Wait a few minutes until the oil settles before checking.

3. Wipe the oil off the dipstick. Insert the dipstick back into the engine oil filler hole, but do not screw it in. Then pull out the dipstick again.

The oil level should be between the minimum and maximum marks on the dipstick. If the level is low, add sufficient oil through the engine oil filler hole to reach the specified level.

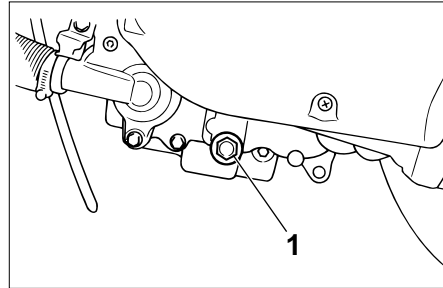

1. Drain bolt

Engine oil replacement

1. Warm up the engine for a few minutes.
2. Stop the engine. Place an oil pan under the engine to catch the oil and remove the oil filler cap.
3. Remove the drain bolt and drain the oil.

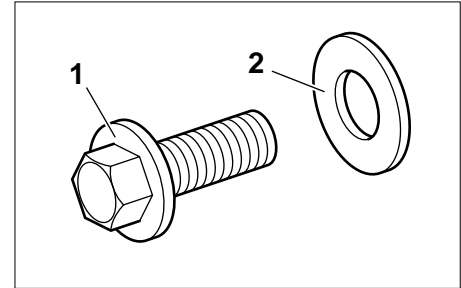

1. Drain bolt
2. Washer

4. Check the washer and replace it if damaged.
5. Install the washer and drain bolt, and then tighten the drain bolt to the specified torque.

Tightening torque:

Drain bolt:

20 Nm (2.0 m·kg)

NOTE: _____

Make sure the washer is seated properly.

PERIODIC MAINTENANCE AND MINOR REPAIR

6. Fill the engine with oil and install the oil filler cap.

Recommended oil:

See page 8-1.

Oil quantity:

Total amount: 1.4 L

Periodic oil change: 1.2 L

EC000030

CAUTION:

- Do not put in any chemical additives or use oils with a grade of CD or higher. Also, be sure not to use oils labeled “ENERGY CONSERVING II” or higher.
- Be sure no foreign material enters the crankcase.

7. Start the engine and warm it up for a few minutes. While warming up, check for oil leakage. If oil leakage is found, stop the engine immediately and check for the cause.

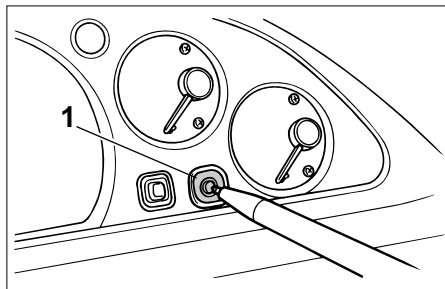

1. Oil change indicator light reset button

Resetting the oil change indicator light

1. Turn the key to “ON”.
2. Push and hold in the reset button for 2 ~ 5 seconds.
3. Release the reset button and the oil change indicator light will go off.

NOTE:

If the oil is changed before the oil change indicator light comes on (i.e. before the 3,000-km oil change interval is reached), be sure to reset it after changing the oil, so that it will come on at the correct time to indicate the next 3,000-km oil replacement.

To reset the oil change indicator light before it comes on, follow steps 1 and 2. Then, release the reset button and the oil change indicator light will come on for 1.4 seconds. If it does not come on for 1.4 seconds, repeat the procedure.

PERIODIC MAINTENANCE AND MINOR REPAIR

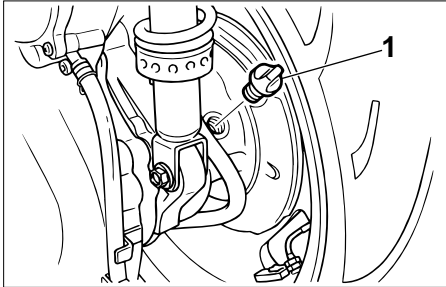

1. Final gear oil filler cap

EAU03120*

Final gear oil replacement

1. Put the scooter on the center-stand.
2. Place an oil pan under the final gear case to catch the oil.
3. Remove the oil filler cap and the drain bolt to drain the oil.
4. Install and tighten the drain bolt to the specified torque.

Tightening torque:
Drain bolt:
22 Nm (2.2 m·kg)

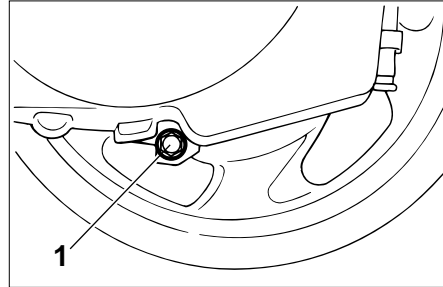

1. Drain bolt

5. Fill the gear case with the recommended oil.

Recommended final gear oil:
SAE 10W30 type SE motor oil
Final gear case capacity:
0.25 L

EW000066

⚠ WARNING

Do not let foreign material enter the final gear case. Be sure oil does not get on the tire or wheel.

6. Install the oil filler cap.
7. After replacing the final gear oil, be sure to check for oil leakage.

PERIODIC MAINTENANCE AND MINOR REPAIR

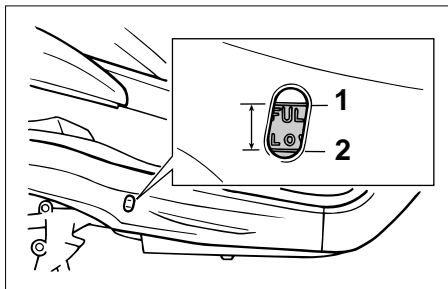

1. Maximum level mark
2. Minimum level mark

EAU01587

Coolant

The coolant reservoir tank is located under the battery cover. (See page 6-26 for battery cover removal procedures.)

Check the coolant level in the reservoir tank when the engine is cold. The coolant level will vary with engine temperature. The coolant level is satisfactory if it is between the minimum and maximum marks on the tank. If the coolant level is at or below the minimum mark, fill with tap water (soft water) to bring the level up to the maximum mark.

Have a Yamaha dealer change the

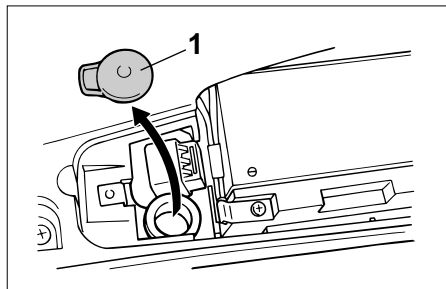

1. Coolant reservoir tank cap

coolant every two years.

If your scooter overheats, see page 6-35 for details.

EW000067

WARNING

Do not remove the radiator cap when the engine is hot.

EC000080

CAUTION:

Hard water or salt water is harmful to the engine. You may use distilled water if you can't get soft water.

Reservoir tank capacity:
0.4 L

NOTE:

The radiator fan operation is completely automatic. It is switched on or off according to the coolant temperature in the radiator.

PERIODIC MAINTENANCE AND MINOR REPAIR

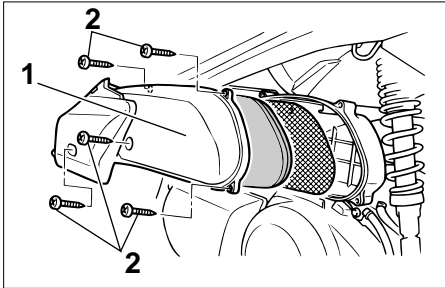

1. Air filter case cover
2. Screw (x5)

EAU03113*

Air filter and V-belt case air filter cleaning

The air filter and V-belt case air filter should be cleaned at the specified intervals.

They should be cleaned more frequently if you are riding in unusually wet or dusty areas.

1. Place the scooter on the center-stand.
2. Remove panel C. (See page 6-8 for panel removal and installation procedures.)
3. Remove the air filter case cover by removing the screws.

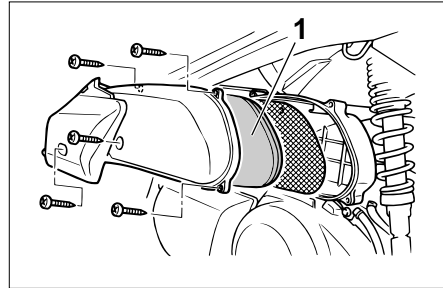

1. Air filter element

4. Remove the air filter element and wash it gently, but thoroughly in solvent. If the air filter element is damaged, replace it.

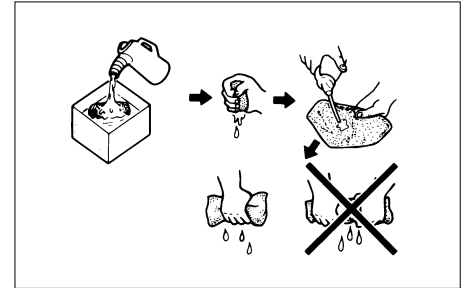

5. Squeeze out the excess solvent and allow it to dry.
6. Apply oil to the entire surface of the air filter element and squeeze out the excess oil. It should be damp, but not dripping.

Recommended oil:
Engine oil

7. Install the air filter element and the air filter case cover.

PERIODIC MAINTENANCE AND MINOR REPAIR

EC000092

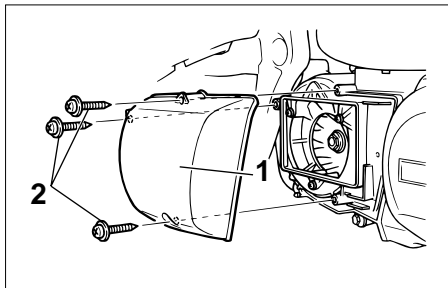

1. V-belt case air filter cover
2. Screw (x3)

8. Remove the V-belt case air filter cover by removing the screws.

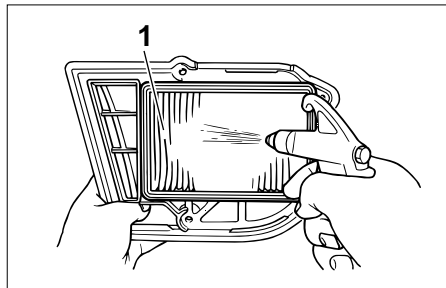

1. V-belt case air filter

9. Remove the V-belt case air filter element and blow out the dirt with compressed air from the inner side of the V-belt case air filter element. If the V-belt case air filter element is damaged, replace it.

10. Install the V-belt case air filter element with the colored side facing outward, and then install the V-belt case air filter cover.

CAUTION:

- Make sure both filters are properly seated in their cases.
- The engine should never be run without the filters installed.

11. Install panel C.

PERIODIC MAINTENANCE AND MINOR REPAIR

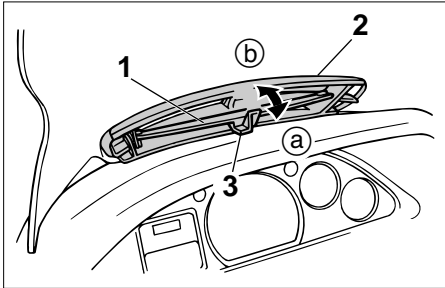

1. Louver
2. Air inlet
3. Lever

EAU03094*

Air flow louver

Opening the air flow louver may help reduce air turbulence.

To open the air flow louver, move the lever in direction (a).

To close the air flow louver, move the lever in direction (b).

ECA00049*

CAUTION:

Be sure to close the louver when riding in the rain and when washing the scooter.

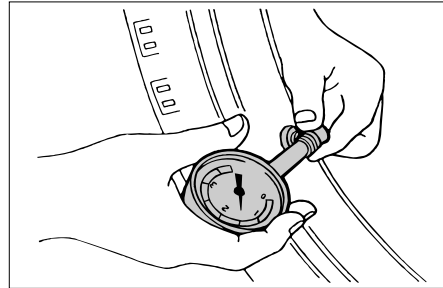

EAU00675

Tires

To ensure maximum performance, long service and safe operation, note the following:

Tire air pressure

Always check and adjust the tire pressure before operating the scooter.

WARNING

EW000082

Tire inflation pressure should be checked and adjusted when the temperature of the tire equals the ambient air temperature. Tire inflation pressure must be adjusted according to total weight of cargo, rider, passenger, and accessories (fairing, saddlebags, etc. if approved for this model), and vehicle speed.

Maximum load*	187 kg	
	Cold tire pressure	Front
Up to 90 kg	175 kPa (1.75 kg/cm ² , 1.75 bar)	200 kPa (2.00 kg/cm ² , 2.00 bar)
90 kg load ~ maximum load*	200 kPa (2.00 kg/cm ² , 2.00 bar)	225 kPa (2.25 kg/cm ² , 2.25 bar)

* Load is the total weight of cargo, rider, passenger and accessories.

PERIODIC MAINTENANCE AND MINOR REPAIR

⚠ WARNING

EW000083

Proper loading of your scooter is important for several characteristics of your scooter, such as handling, braking, performance and safety. Do not carry loosely packed items that can shift. Securely pack your heaviest items close to the center of the scooter, and distribute the weight evenly from side to side. Properly adjust the suspension for your load, and check the condition and pressure of your tires. **NEVER OVERLOAD YOUR SCOOTER.** Make sure the total weight of the cargo, rider, passenger, and accessories (fairing, saddlebags, etc. if approved for this model) does not exceed the maximum load of the scooter. Operation of an overloaded scooter could cause tire damage, an accident, or even injury.

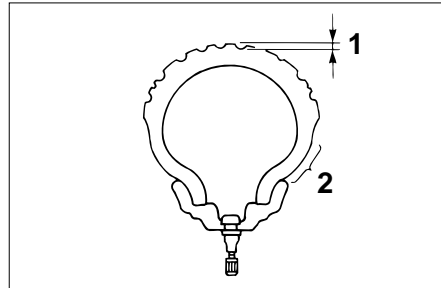

1. Tread depth
2. Side wall

Tire inspection

Always check the tires before operating the scooter. If center tread depth reaches the limit as shown, if the tire has a nail or glass fragments in it, or if the side wall is cracked, contact a Yamaha dealer immediately and have the tire replaced.

FRONT

Manufacturer	Size	Type
INOUE	110/90-12 64L	MB67
MICHELIN	110/90-12 64L	BOPPER

REAR

Manufacturer	Size	Type
INOUE	130/70-12 62L	MB67
MICHELIN	130/70-12 62L	BOPPER

Minimum tire tread depth (front and rear)	1.6 mm
-------------------------------------------	--------

NOTE:

These limits may be different by regulation from country to country. If so, conform to the limits specified by the regulations of your own country.

PERIODIC MAINTENANCE AND MINOR REPAIR

⚠ WARNING

EW000079

Operating the scooter with excessively worn tires decrease riding stability and can lead to loss of control. Have excessively worn tires replaced by a Yamaha dealer immediately. Brakes, tires, and related wheel parts replacement should be left to a Yamaha Service Technician.

Wheels

EAU00687

To ensure maximum performance, long service, and safe operation, note the following:

- Always inspect the wheels before a ride. Check for cracks, bends, or warpage of the wheels. If any abnormal condition exists in a wheel, consult a Yamaha dealer. Do not attempt even small repairs to the wheel. If a wheel is deformed or cracked, it must be replaced.
- Tires and wheels should be balanced whenever either one is changed or replaced. Failure to have a wheel balanced can result in poor performance, adverse handling characteristics, and shortened tire life.
- Ride at moderate speeds after changing a tire since the tire surface must first be broken in for it to develop its optimal characteristics.

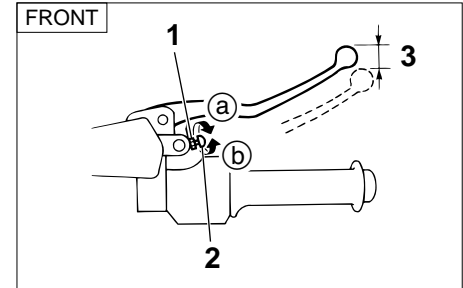

1. Locknut
2. Adjusting bolt
3. Free play

EAU00703

Brake lever free play adjustment

The front brake lever free play should be adjusted to 2 ~ 5 mm at the brake lever end.

PERIODIC MAINTENANCE AND MINOR REPAIR

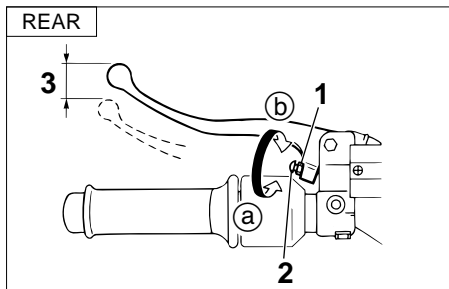

1. Locknut
2. Adjusting bolt
3. Free play

The rear brake lever free play should be adjusted to 2 ~ 5 mm at the brake lever end.

Loosen the locknut and turn the adjusting bolt in direction (a) to increase free play and in direction (b) to decrease free play.

Be sure to tighten the locknut after adjusting.

EW000101

⚠ WARNING

When it is impossible to make the proper adjustment, ask a Yamaha dealer.

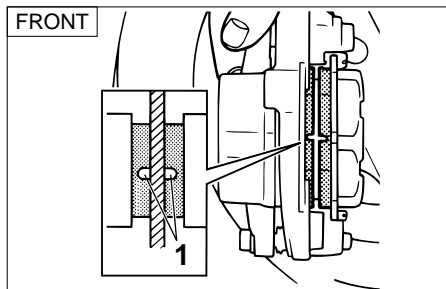

1. Wear indicator groove (x2)

Checking the front and rear brake pads

EAU01314

Each brake pad is provided with a wear indicator groove, which allows checking the brake pad for wear without disassembling the brake.

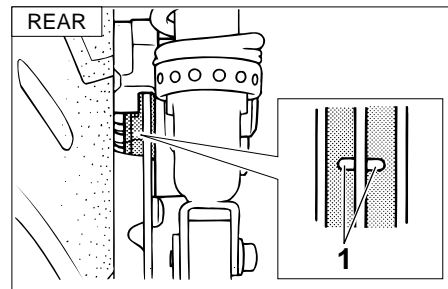

1. Wear indicator groove (x2)

Inspect each wear indicator groove and, as soon as one of them has almost worn away, ask a Yamaha dealer to replace the brake pads as a set.

PERIODIC MAINTENANCE AND MINOR REPAIR

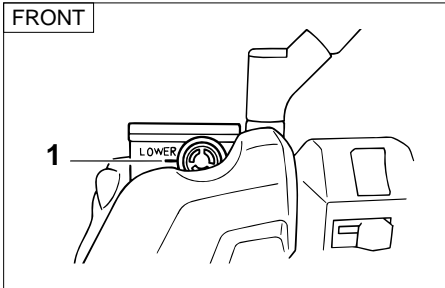

1. Minimum level mark

EAU00731

Inspecting the brake fluid level

Insufficient brake fluid may let air enter the brake system, possibly causing the brakes to become ineffective.

Before riding, check that the brake fluid is above the minimum level and replenish when necessary.

Observe these precautions:

- When checking the fluid level, make sure the top of the master cylinder is level by turning the handlebars.

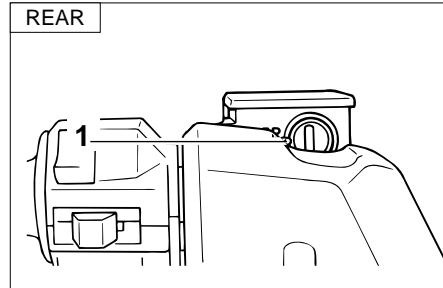

1. Minimum level mark

- Use only the designated quality brake fluid. Otherwise, the rubber seals may deteriorate, causing leakage and poor brake performance.

Recommended brake fluid:
DOT 4

- Refill with the same type of brake fluid. Mixing fluids may result in a harmful chemical reaction and lead to poor brake performance.

- Be careful that water does not enter the master cylinder when refilling. Water will significantly lower the boiling point of the fluid and may result in vapor lock.
- Brake fluid may deteriorate painted surfaces or plastic parts. Always clean up spilled fluid immediately.
- Have a Yamaha dealer check the cause if the brake fluid level goes down.

PERIODIC MAINTENANCE AND MINOR REPAIR

EAU00742

Brake fluid replacement

The brake fluid should be replaced only by trained Yamaha service personnel. Have the Yamaha dealer replace the following components during periodic maintenance or when they are damaged or leaking:

- oil seals (every two years)
- brake hoses (every four years)

EAU02962

Cable inspection and lubrication

EW000112

⚠ WARNING

Damage to the outer housing of cables may lead to internal rusting and interfere with the cable movement. Replace damaged cables as soon as possible to prevent unsafe conditions.

Lubricate the cables and cable ends. If a cable does not operate smoothly, ask a Yamaha dealer to replace it.

Recommended lubricant:
Engine oil

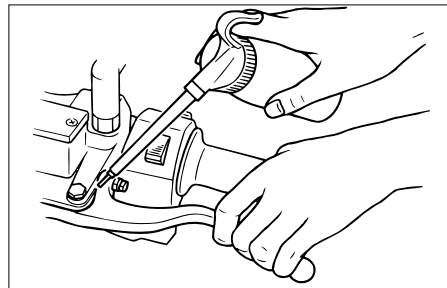

EAU03118*

Brake lever lubrication

Lubricate the pivoting parts of both brake levers.

Recommended lubricant:
Engine oil

PERIODIC MAINTENANCE AND MINOR REPAIR

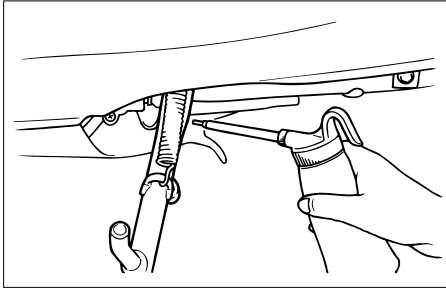

EAU02965

Center and sidestand lubrication

Lubricate the pivoting and mating joints.

Check to see that the center and sidestand move up and down smoothly.

Recommended lubricant:
Engine oil

EW000114

⚠WARNING

If the center and/or sidestand does not move smoothly, consult a Yamaha dealer.

EAU02939

Front fork inspection Visual check

⚠WARNING

Securely support the scooter so there is no danger of it falling over.

Check for scratches or damage on the inner tube and excessive oil leakage from the front fork.

EW000115

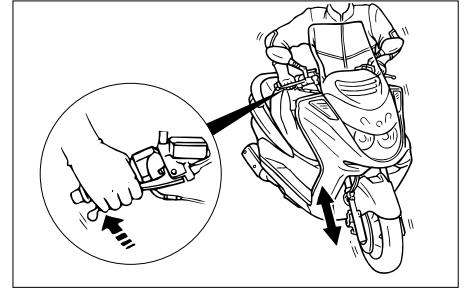

Operation check

1. Place the scooter on a level place.
2. Hold the scooter in an upright position and apply the front brake.
3. Push down hard on the handlebars several times and check if the fork rebounds smoothly.

EC000098

CAUTION:

If any damage or unsmooth movement is found with the front fork, consult a Yamaha dealer.

PERIODIC MAINTENANCE AND MINOR REPAIR

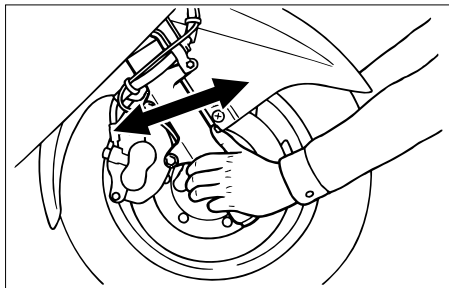

EAU00794

Steering inspection

Periodically inspect the condition of the steering. Worn out or loose steering bearings may be dangerous. Place a stand under the engine to raise the front wheel off the ground. Hold the lower end of the front forks and try to move them forward and backward. If any free play can be felt, ask a Yamaha dealer to inspect and adjust the steering. Inspection is easier if the front wheel is removed.

EW000115

⚠WARNING

Securely support the scooter so there is no danger of it falling over.

EAU01144

Wheel bearings

If there is play in the front or rear wheel hub or if the wheel does not turn smoothly, have a Yamaha dealer inspect the wheel bearings.

PERIODIC MAINTENANCE AND MINOR REPAIR

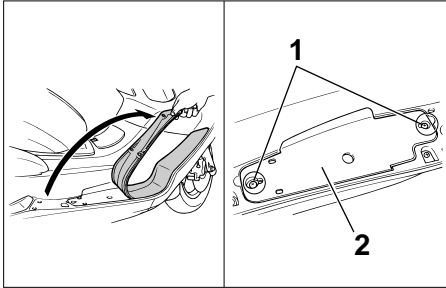

1. Screw (x2)
2. Battery cover

EAU00796

Battery cover removal

Pull up the right floorboard mat as shown. Then remove the screws and the battery cover.

NOTE:

The battery cover needs to be removed to access the fuse box and the coolant reservoir tank cap.

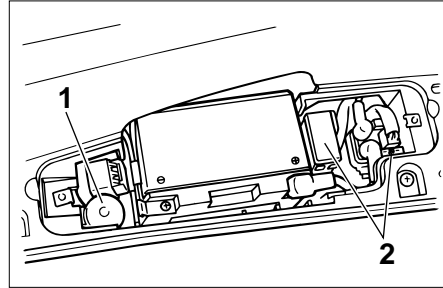

1. Coolant reservoir tank cap
2. Fuse box (x2)

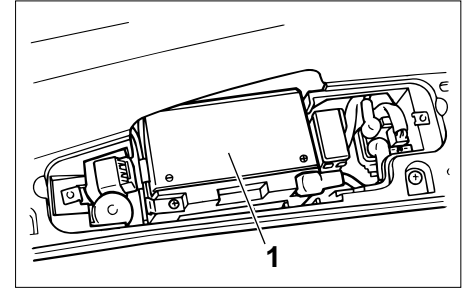

1. Battery

EAU01271

Battery

This scooter is equipped with a sealed-type battery. Therefore it is not necessary to check the electrolyte or fill the battery with distilled water.

- If the battery seems to have discharged, consult a Yamaha dealer.
- If the scooter is equipped with optional electrical accessories, the battery tends to discharge more quickly, so be sure to recharge it periodically.

PERIODIC MAINTENANCE AND MINOR REPAIR

⚠ WARNING

EW000116

Battery electrolyte is poisonous and dangerous, causing severe burns, etc. It contains sulfuric acid. Avoid contact with skin, eyes or clothing.

ANTIDOTE:

- **EXTERNAL:** Flush with water.
- **INTERNAL:** Drink large quantities of water or milk. Follow with milk of magnesia, beaten egg, or vegetable oil. Call a physician immediately.
- **EYES:** Flush with water for 15 minutes and get prompt medical attention.

Batteries produce explosive gases. Keep sparks, flame, cigarettes etc., away. Ventilate when charging or using in an enclosed space. Always shield your eyes when working near batteries.

KEEP OUT OF REACH OF CHILDREN.

Battery storage

When the scooter is not used for a month or longer, remove the battery, fully charge it and store it in a cool, dry place.

CAUTION:

EC000102

- **Completely recharge the battery before storing. Storing a discharged battery can cause permanent battery damage.**
- **Use a battery charger designed for a sealed-type (MF) battery. Using a conventional battery charger will cause battery damage. If you do not have a sealed-type battery charger, contact your Yamaha dealer.**
- **Always make sure the connections are correct when reinstalling the battery.**

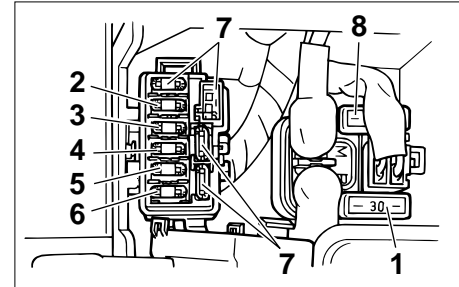

1. Main fuse
2. Clock fuse (back up)
3. Radiator fan fuse
4. Ignition fuse
5. Headlight fuse
6. Signaling system fuse
7. Spare fuse (x4)
8. Spare main fuse

EAU03095*

Fuse replacement

The main fuse and fuse box are located beside the battery.

1. Remove the battery cover by removing the screws.

PERIODIC MAINTENANCE AND MINOR REPAIR

2. If a fuse is blown, turn off the ignition switch and the switch of the circuit in question. Install a new fuse of specified amperage. Turn on the switches, and see if the electrical device operates. If the fuse immediately blows again, consult a Yamaha dealer.

EC000103

CAUTION:

Do not use fuses of higher amperage rating than those recommended. Substitution of a fuse of improper rating can cause extensive electrical system damage and possibly a fire.

Specified fuses:

- Main fuse: 30 A
- Clock fuse (back up): 10 A
- Radiator fan fuse: 4 A
- Ignition fuse: 7.5 A
- Headlight fuse: 15 A
- Signaling system fuse: 15 A

EAU03112*

Headlight bulb replacement

This scooter is equipped with quartz bulb headlights.

If a headlight bulb burns out, replace the bulb as follows:

1. Place the scooter on the center-stand.
2. Remove panel B. (See page 6-8 for panel removal and installation procedures.)

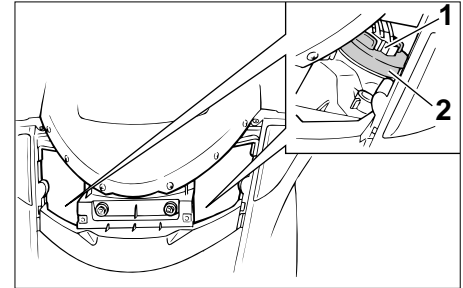

1. Coupler (×2)
2. Bulb holder cover (×2)
3. Disconnect the headlight coupler and remove the bulb holder cover.

PERIODIC MAINTENANCE AND MINOR REPAIR

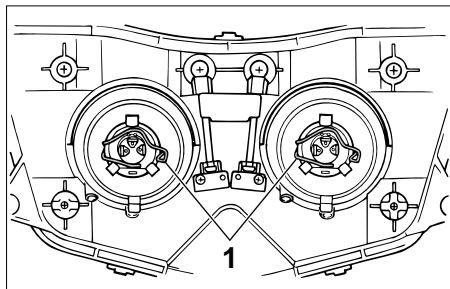

1. Bulb holder (x2)

4. Unhook the bulb holder to remove the defective bulb.

EW000119

⚠ WARNING

Keep flammable products and your hands away from a bulb while it is on, as it is hot. Do not touch a bulb until it cools down.

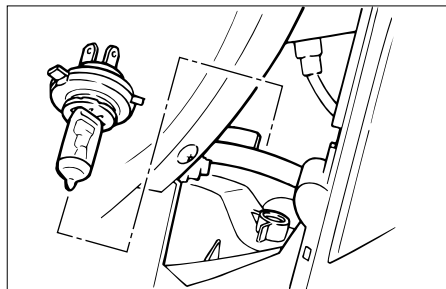

5. Put a new bulb into position and secure it in place with the bulb holder.

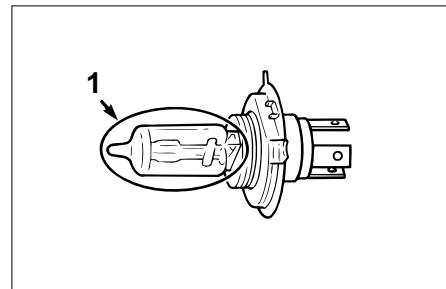

1. Don't touch

EC000105

CAUTION:

Avoid touching the glass part of a bulb. Keep it free from oil; otherwise, the transparency of the glass, life of the bulb, and luminous flux will be adversely affected. If oil gets on a bulb, thoroughly clean it with a cloth moistened with alcohol or lacquer thinner.

6. Install the bulb holder cover and connect the headlight coupler.
7. Install the panel.

If necessary, ask a Yamaha dealer to adjust the headlight beam.

PERIODIC MAINTENANCE AND MINOR REPAIR

Tail/brake light bulb replacement

EAU03115*

1. Place the scooter on the center-stand.
2. Remove panel A. (See page 6-6 for panel removal and installation procedures.)

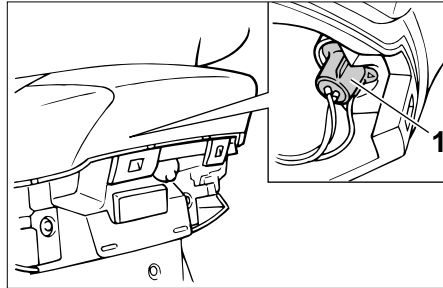

1. Bulb socket (x2)
3. Turn the tail/brake light bulb socket counterclockwise to remove it.
4. Remove the defective bulb by pushing it inward and turning it counterclockwise.
5. Install a new bulb by pushing it inward and turning it clockwise.
6. Install the tail/brake light bulb socket into the original position and turn it clockwise.
7. Install the panel.

Front turn signal light bulb replacement

EAU03111*

1. Place the scooter on the center-stand.
2. Remove panel B. (See page 6-8 for panel removal and installation procedures.)

PERIODIC MAINTENANCE AND MINOR REPAIR

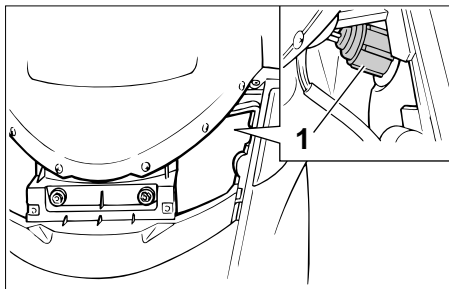

1. Bulb socket

3. Remove the front turn signal light bulb socket by turning it counter-clockwise.
4. Remove the defective bulb by pushing it inward and turning it counterclockwise.
5. Install a new bulb by pushing it inward and turning it clockwise.
6. Install the front turn signal light bulb socket into the original position and turn it clockwise.
7. Install the panel.

EAU03116*

Rear turn signal light bulb replacement

1. Place the scooter on the center-stand.
2. Remove panel A. (See page 6-6 for panel removal and installation procedures.)

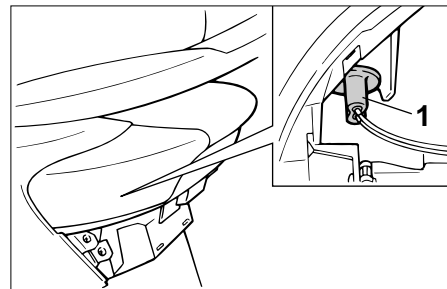

1. Bulb socket

3. Turn the rear turn signal light bulb socket counterclockwise to remove it.
4. Pull out the defective bulb.
5. Install a new bulb by pushing it inward.
6. Install the rear turn signal light bulb socket into the original position and turn it clockwise.
7. Install the panel.

PERIODIC MAINTENANCE AND MINOR REPAIR

EAU03117*

License light bulb replacement

1. Place the scooter on the center-stand.
2. Remove panel A. (See page 6-6 for panel removal and installation procedures.)

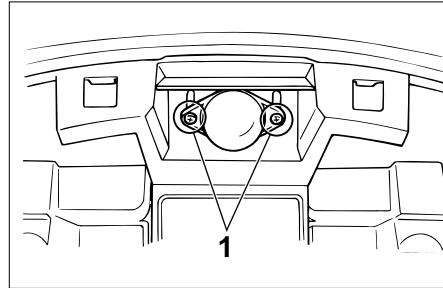

1. Screw (x2)
3. Remove the screws holding the license light lens.

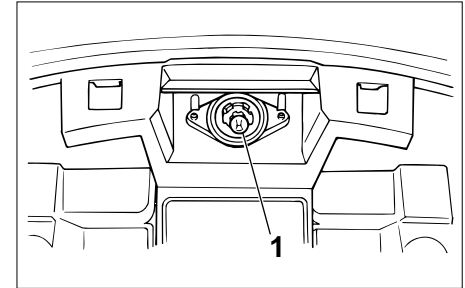

1. Bulb
4. Remove the license light lens and pull out the defective bulb.
5. Install a new bulb.
6. Install the license light lens and screws.
7. Install the panel.

PERIODIC MAINTENANCE AND MINOR REPAIR

EAU01008

Troubleshooting

Although Yamaha scooter receive a rigid inspection before shipment from the factory, trouble may occur during operation.

Any problem in the fuel, compression, or ignition systems can cause poor starting and loss of power. The troubleshooting chart describes a quick, easy procedure for making checks.

If your scooter requires any repair, bring it to a Yamaha dealer. The skilled technicians at a Yamaha dealership have the tools, experience, and know-how to properly service your scooter. Use only genuine Yamaha parts on your scooter. Imitation parts may look like Yamaha parts, but they are often inferior. Consequently, they have a shorter service life and can lead to expensive repair bills.

PERIODIC MAINTENANCE AND MINOR REPAIR

Troubleshooting charts

EAU01581*

EW000125

⚠WARNING

Never check the fuel system while smoking or in the vicinity of an open flame.

1. Fuel

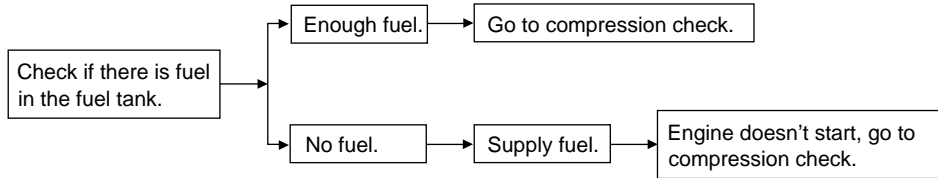

2. Compression

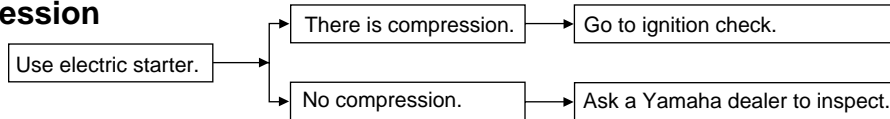

3. Ignition

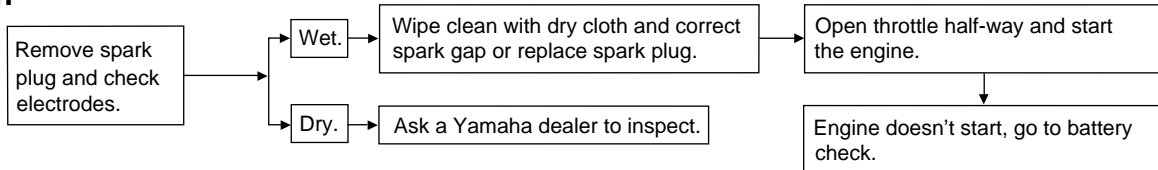

4. Battery

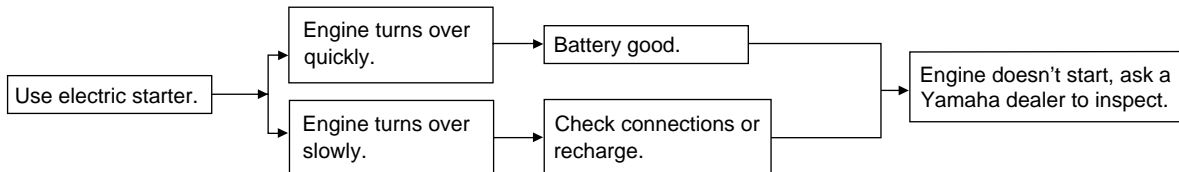

PERIODIC MAINTENANCE AND MINOR REPAIR

Engine overheating

EW000070

⚠WARNING

Do not remove the radiator cap when the engine and radiator are hot. Scalding hot fluid and steam may be blown out under pressure, which could cause serious injury. Open the radiator cap as follows. Wait until the engine has cooled. Remove the radiator cap stopper by removing the screw. Place a thick rag like a towel over the radiator cap and slowly rotate the cap counterclockwise to the detent. This procedure allows any residual pressure to escape. When the hissing sound has stopped, press down on the cap while turning counterclockwise and remove it.

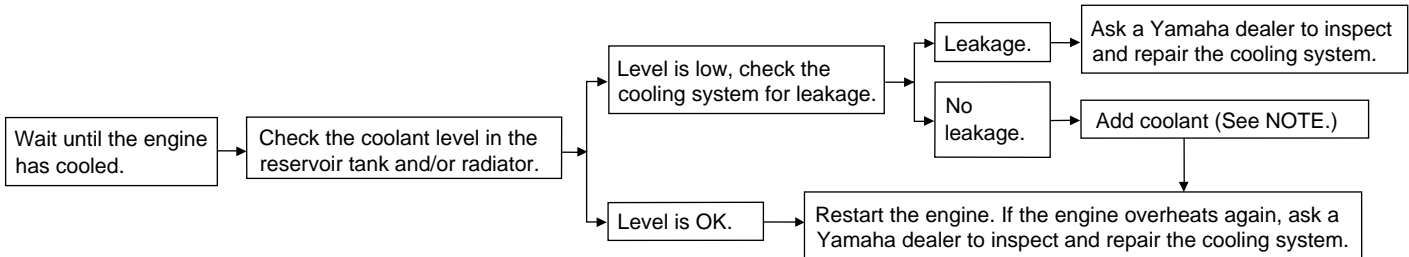

NOTE:

If it is difficult to get the recommended coolant, tap water can be temporarily used, provided that it is changed to the recommended coolant as soon as possible.

SCOOTER CARE AND STORAGE

Care.....	7-1
Storage.....	7-4

SCOOTER CARE AND STORAGE

Care

The exposure of its technology makes a scooter charming but also vulnerable. Although high-quality components are used, they are not all rust-resistant. While a rusty exhaust pipe may remain unnoticed on a car, it does look unattractive on a scooter. Frequent and proper care, however, will keep your scooter looking good, extend its life and maintain its performance. Moreover, the warranty states that the vehicle must be properly taken care of. For all these reasons, it is recommended that you observe the following cleaning and storing precautions.

Before cleaning

1. Cover up the muffler outlet with a plastic bag.
2. Make sure that all caps and covers as well as all electrical couplers and connectors, including the spark plug cap, are tightly installed.
3. Remove extremely stubborn dirt, like oil burnt onto the crankcase, with a degreasing agent and a tooth or bottle brush, but never apply such products onto seals, gaskets and wheel axles. Always rinse the dirt and degreaser off with water.

Cleaning

After normal use

Remove dirt with warm water, a neutral detergent and a soft clean sponge, then rinse with plenty of clean water. Use a brush for hard-to-reach parts. Tougher dirt and insects will come off more easily if the area is covered with a wet cloth for a few minutes before cleaning.

ECA00011

CAUTION: _____

- **Avoid using strong acidic wheel cleaners. If you do use such products for hard-to-remove dirt, do not leave it on any longer than instructed, then thoroughly rinse it off with water, immediately dry the area and apply a corrosion protection spray.**

SCOOTER CARE AND STORAGE

- Improper cleaning can damage windshields, cowlings, panels and other plastic parts. Use only a soft, clean cloth or sponge with mild detergent and water to clean plastic.
 - Do not use any harsh chemical products on plastic parts. Be sure to avoid using cloths or sponges which have been in contact with strong or abrasive cleaning products, solvent or thinner, fuel (gasoline), rust removers or inhibitors, brake fluid, antifreeze or electrolyte.
 - Do not use high-pressure washers or steam-jet cleaners since they cause water seepage and deterioration in the following areas: seals (of wheel bearings, swingarm bearings, bearings, forks and brakes), electric components (couplers, connectors, instruments, switches and lights), breather hoses and vents.
 - For scooters equipped with a windshield: Do not use strong cleaners or hard sponges as they will cause dulling or scratching. Some cleaning compounds for plastic may leave scratches on the windshield. Test the product on a small hidden part of the windshield to make sure they do not leave any marks. If the windshield is scratched, use a quality plastic polishing compound after washing.
-

After riding in the rain, near the sea or on salt-sprayed roads

Since sea salt or salt sprayed on the roads in the winter are extremely corrosive in combination with water, carry out the following steps after each ride in the rain, near the sea or on salt-sprayed roads. (Salt sprayed in the winter may remain on the roads well into spring.)

1. Clean your scooter with cold water and soap after the engine has cooled down.

ECA00012

CAUTION: _____

Do not use warm water since it increases the corrosive action of the salt.

2. Be sure to apply a corrosion protection spray on all (even chrome- and nickel-plated) metal surfaces to prevent corrosion.

SCOOTER CARE AND STORAGE

After cleaning

1. Dry the scooter with a chamois or an absorbing cloth.
2. Use a chrome polish to shine chrome, aluminum and stainless-steel parts, including the exhaust system. (Even the thermally induced discoloring of stainless-steel exhaust systems can be removed through polishing.)
3. To prevent corrosion, it is recommended to apply a corrosion protection spray on all (even chrome- and nickel-plated) metal surfaces.
4. Use spray oil as a universal cleaner to remove any remaining dirt.
5. Touch up minor paint damage caused by stones, etc.

6. Wax all painted surfaces.
7. Let the scooter dry completely before storing it or covering it.

⚠ WARNING

EWA00002

Make sure that there is no oil or wax on the brakes and tires. If necessary, clean the brake discs and linings with a regular brake disc cleaner or acetone, and wash the tires with warm water and mild soap. Then, carefully test the scooter for its braking performance and cornering behavior.

ECA00013

CAUTION:

- **Apply spray oil and wax sparingly and wipe off any excess.**
 - **Never apply oil or wax on rubber and plastic parts, but treat them with a suitable care product.**
 - **Avoid using abrasive polishing compounds as they wear away the paint.**
-

NOTE:

Consult a Yamaha dealer for advice on what products to use.

SCOOTER CARE AND STORAGE

Storage

Short-term

Always store your scooter in a cool, dry place and, if necessary, protect it against dust with a porous cover.

ECA00015

CAUTION:

- **Storing the scooter in a poorly ventilated room or covering it with a tarp while it is still wet will allow water and humidity to seep in and cause rust.**
- **To prevent corrosion, avoid damp cellars, stables (because of the presence of ammonia) and areas where strong chemicals are stored.**

Long-term

Before storing your scooter for several months:

1. Follow all the instructions in the “Care” section of this chapter.
2. Drain the carburetor float chamber by loosening the drain bolt; this will prevent fuel deposits from building up. Pour the drained fuel into the fuel tank.
3. Only for scooters equipped with a fuel cock which has an “OFF” position: Turn the fuel cock to “OFF”.
4. Fill up the fuel tank and add fuel stabilizer (if available) to prevent the fuel tank from rusting and the fuel from deteriorating.
5. Perform the following steps to protect the cylinder, piston rings, etc. from corrosion.

- a. Remove the spark plug cap and spark plug.
- b. Pour a teaspoonful of engine oil into the spark plug bore.
- c. Install the spark plug cap onto the spark plug and place the spark plug on the cylinder head so that the electrodes are grounded. (This will limit sparking during the next step.)
- d. Turn the engine over several times with the starter. (This will coat the cylinder wall with oil.)
- e. Remove the spark plug cap from the spark plug, install the spark plug and then the spark plug cap.

EWA00003

⚠ WARNING

When turning the engine over, be sure to ground the spark plug electrodes to prevent damage or injury from sparking.

SCOOTER CARE AND STORAGE

6. Lubricate all control cables and the pivoting points of all levers and pedals as well as of the sidestand/centerstand.
7. Check and, if necessary, correct the tire air pressure, then raise the scooter so that both of its wheels are off the ground. Alternatively, turn the wheels a little every month in order to prevent the tires from becoming degraded in one spot.
8. Cover up the muffler outlet with a plastic bag to prevent moisture from entering.
9. Remove the battery and fully charge it. Store it in a cool, dry place and recharge it once a month. Do not store the battery in an excessively cold or warm place (less than 0 °C or more than 30 °C).
For more information, see “Battery storage” in the chapter “PERIODIC MAINTENANCE AND MINOR REPAIRS”.

NOTE: _____

Make any necessary repairs before storing the scooter.

Specifications	8-1
How to use the conversion table	8-5

SPECIFICATIONS

Specifications

Model	YP250
Dimensions	
Overall length	2,140 mm
Overall width	780 mm
Overall height	1,350 mm
Seat height	730 mm
Wheelbase	1,535 mm
Ground clearance	120 mm
Minimum turning radius	2,700 mm
Basic weight (with oil and full fuel tank)	168 kg
Engine	
Engine type	Liquid-cooled 4-stroke, SOHC
Cylinder arrangement	Forward inclined single cylinder
Displacement	249 cm ³
Bore × Stroke	69.0 × 66.8 mm
Compression ratio	10:1
Starting system	Electric starter
Lubrication system	Wet sump

Engine oil

Type

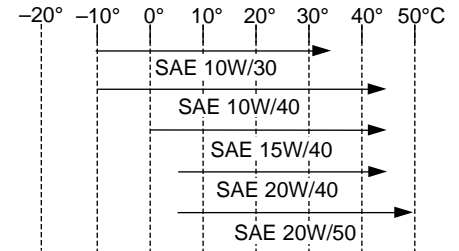

Recommended engine oil classification

API Service SE, SF, SG type or higher

CAUTION:

Be sure to use motor oils that do not contain anti-friction modifiers. Passenger car motor oils (often labeled “Energy Conserving”) contain anti-friction additives which will cause clutch and/or starter clutch slippage, resulting in reduced component life and poor engine performance.

Capacity

Periodic oil change	1.2 L
Total amount	1.4 L

Final gear oil

Type	SAE 10W30 type SE motor oil
Final gear case capacity	0.25 L

Air filter

Wet element

Fuel

Type	Regular unleaded gasoline
Fuel tank capacity	12 L

Carburetor

Type × quantity	Y28V-1E × 1
Manufacturer	TEIKEI

Spark plug

Manufacturer/type	NGK / DR8EA
Spark plug gap	0.6 ~ 0.7 mm

Clutch type

Dry, centrifugal automatic

Transmission

Primary reduction system	Helical gear
Primary reduction ratio	40/15 (2.666)
Secondary reduction system	Helical gear
Secondary reduction ratio	38/15 (2.533)
Transmission type	V-belt automatic
Operation	Centrifugal automatic type

Chassis

Frame type	Steel tube underbone
Caster angle	28°
Trail	103 mm

Tire

Front	Type	Tubeless
	Size	110/90-12 64L
	Manufacturer/ model	INOUE / MB67 MICHELIN / BOPPER
Rear	Type	Tubeless
	Size	130/70-12 62L
	Manufacturer/ model	INOUE / MB67 MICHELIN / BOPPER

Maximum load* 187 kg

Air pressure (cold tire)

up to 90 kg load*

Front	175 kPa (1.75 kg/cm ² , 1.75 bar)
Rear	200 kPa (2.00 kg/cm ² , 2.00 bar)

SPECIFICATIONS

90 kg load ~ maximum
load*

Front	200 kPa (2.00 kg/cm ² , 2.00 bar)
Rear	225 kPa (2.25 kg/cm ² , 2.25 bar)

* Load is total weight of cargo, rider, passenger and accessories.

Wheels

Front

Type	Cast wheel
Size	12 × MT2.75

Rear

Type	Cast wheel
Size	12 × MT3.50

Brakes

Front

Type	Single disc brake
Operation	Right hand operation
Fluid	DOT 4

Rear

Type	Single disc brake
Operation	Left hand operation
Fluid	DOT 4

Suspension

Front	Telescopic fork
Rear	Unit swing

Shock absorbers

Front	Coil spring/oil damper
Rear	Coil spring/oil damper

Wheel travel

Front	100 mm
Rear	90 mm

Electrical

Ignition system	T.C.I. (digital)
Charging system	
Type	A.C. magneto
Standard output	14 V, 19.5 A @ 5,000 r/min
Battery	
Type	GT7B-4
Voltage, capacity	12 V, 6.5 AH

Headlight bulb type

Halogen bulb

Bulb voltage, wattage × quantity

Headlight	12 V, 60/55 W × 1 12 V, 55 W × 1
Tail/brake light	12 V, 5/21 W × 2

Front turn signal light	12 V, 21 W × 2
Rear turn signal light	12 V, 16 W × 2
Auxiliary light	12 V, 5 W × 1
License plate light	12 V, 5 W × 1
Meter lighting	12 V, 1.7 W × 3
High beam indicator light	12 V, 1.7 W × 1
Oil change indicator light	12 V, 1.7 W × 1
Turn indicator light	12 V, 3.4 W × 2

Fuses

Main fuse	30 A
Headlight fuse	15 A
Signaling system fuse	15 A
Ignition fuse	7.5 A
Radiator fan fuse	4 A
Clock fuse (back up)	10 A

SPECIFICATIONS

EAU01064

HOW TO USE THE CONVERSION TABLE

All specification data in this manual are listed in SI and METRIC UNITS.

Use this table to convert METRIC unit data to IMPERIAL unit data.

Ex.

METRIC		MULTIPLIER	=	IMPERIAL
** mm	×	0.03937	=	** in
2 mm	×	0.03937	=	0.08 in

CONVERSION TABLE

METRIC TO IMPERIAL			
	Metric unit	Multiplier	Imperial unit
Torque	m • kg	7.233	ft • lb
	m • kg	86.794	in • lb
	cm • kg	0.0723	ft • lb
	cm • kg	0.8679	in • lb
Weight	kg	2.205	lb
	g	0.03527	oz
Speed	km/hr	0.6214	mph
Distance	km	0.6214	mi
	m	3.281	ft
	m	1.094	yd
	cm	0.3937	in
Volume/ Capacity	mm	0.03937	in
	cc (cm3)	0.03527	oz (IMP liq.)
	cc (cm3)	0.06102	cu • in
	lt (liter)	0.8799	qt (IMP liq.)
Misc.	lt (liter)	0.2199	gal (IMP liq.)
	kg/mm	55.997	lb/in
	kg/cm2	14.2234	psi (lb/in2)
	Centigrade(°C)	9/5 + 32	Fahrenheit(°F)

Identification number records9-1
Key identification number9-1
Vehicle identification number.....9-1
Model label9-2

CONSUMER INFORMATION

EAU02944

Identification number records

Record the key identification number, vehicle identification number and model label information in the spaces provided for assistance when ordering spare parts from a Yamaha dealer or for reference in case the vehicle is stolen.

1. KEY IDENTIFICATION NUMBER:

2. VEHICLE IDENTIFICATION NUMBER:

3. MODEL LABEL INFORMATION:

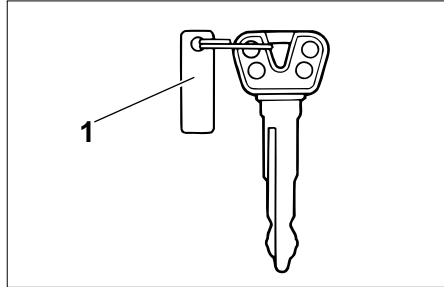

1. Key identification number

EAU01041

Key identification number

The key identification number is stamped on the key tag. Record this number in the space provided and use it for reference when obtaining a new key.

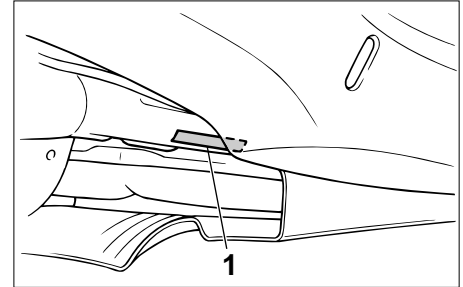

1. Vehicle identification number

EAU01044

Vehicle identification number

The vehicle identification number is stamped into the frame.

NOTE: _____
The vehicle identification number is used to identify your scooter and may be used to register your scooter with the licensing authority in your state.

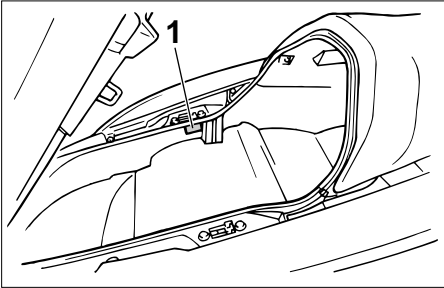

1. Model label

EAU01804

Model label

The model label is affixed to the frame under the rider seat. (See page 3-12 for rider seat removal and installation procedures.)

Record the information on this label in the space provided. This information will be needed to order spare parts from your Yamaha dealer.

INDEX

A

Acceleration.....	5-2
Air filter and V-belt case filter cleaning	6-16
Air flow louver.....	6-18
Anti theft alarm (optional)	3-5

B

Battery	6-26
Battery cover removal	6-26
Brake fluid replacement.....	6-23
Brake lever free play adjustment.....	6-20
Brake lever lubrication.....	6-23
Braking	5-2

C

Cable inspection and lubrication	6-23
Care.....	7-1
Carrier (option)	3-16
Catalyzer	3-12
Center and sidestand lubrication.....	6-24
Checking the front and rear brake pads	6-21
Coolant.....	6-15
Coolant temperature gauge.....	3-5

D

Description	2-1
Diagnosis device	3-4
Digital clock	3-6
Dimmer switch.....	3-6

E

Engine break-in	5-3
Engine oil.....	6-11
Engine stop switch	3-9

F

Final gear oil replacement	6-14
Front brake lever	3-9
Front fork inspection.....	6-24
Front turn signal light bulb replacement	6-30
Fuel	3-11
Fuel gauge	3-5
Fuel tank cap.....	3-10
Fuse replacement.....	6-27

H

Handlebar switches	3-6
Dimmer switch	3-6
Engine stop switch	3-9
Pass switch.....	3-6
Turn signal switch	3-7
Horn switch	3-7
Light switch	3-7
Start switch	3-9
Headlight beam variation.....	3-8
Headlight bulb replacement.....	6-28
High beam indicator light.....	3-2
Horn switch.....	3-7
How to use the conversion table	8-5

I

Identification number records	9-1
-------------------------------------	-----

Indicator lights	3-2
Turn indicator lights	3-2
High beam indicator light	3-2
Oil change indicator light	3-2
Inspecting the brake fluid level	6-22

K

Key identification number	9-1
---------------------------------	-----

L

License light bulb replacement.....	6-32
Light switch.....	3-7

M

Main switch / Steering lock.....	3-1
Model label.....	9-2

O

Oil change indicator light circuit check	3-3
Oil change indicator light	3-2

P

Panel A	6-6
Panel B	6-8
Panel C.....	6-8
Panel removal and installation	6-6
Parking	5-4
Pass switch	3-6
Periodic maintenance and lubrication	6-3
Pre-operation check list.....	4-1

R

- Rear brake lever3-10
- Rear shock absorber adjustment3-15
- Rear turn signal light bulb
replacement6-31
- Rider seat3-12
- Rider seat adjustment3-13

S

- Sidestand3-16
- Sidestand switch operation check3-17
- Spark plug6-10
- Specifications8-1
- Speedometer3-4
- Start switch3-9
- Starting a cold engine5-1
- Starting off5-2
- Steering inspection6-25
- Storage7-4
- Storage compartments3-14

T

- Tail/brake light bulb replacement6-30
- Tires6-18
- Tool kit6-1
- Troubleshooting6-33
- Troubleshooting chart6-34
- Turn indicator lights3-2
- Turn signal switch3-7

V

- Vehicle identification number9-1

W

- Wheel bearings6-25
- Wheels6-20



PRINTED ON RECYCLED PAPER

PRINTED IN JAPAN
99-10-1.6×1(E) 