



OWNER'S MANUAL



***XT660R***  
***XT660X***

5VK-F8199-E1

## DECLARATION of CONFORMITY

We

**Company: MORIC CO., LTD.**

**Address: 1450-6 Mori Mori-Machi Shuchi-gun Shizuoka 437-0292 Japan**

Hereby declare that the product:

**Kind of equipment: IMMOBILIZER**

**Type-designation: SSL-00**

is in compliance with following norm(s) or documents:

**R&TTE Directive(1999/5/EC)**

**EN300 330-2 v1.1.1(2001-6), EN60950-1(2001)**

**Two or Three-Wheel Motor Vehicles Directive(97/24/EC: Chapter 8, EMC)**

**Place of issue: Shizuoka, Japan**

**Date of issue: 1 Aug. 2002**

### Revolution record

No.	Contents	Date
1	To change contact person and integrate type-designation.	9 Jun. 2005
2	Version up the norm of EN60950 to EN60950-1	27 Feb. 2006

*27/Feb/2006*

General manager of quality assurance div.

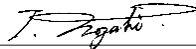

representative name and signature

MORIC CO., LTD.

1450-6 Mori-machi Shuchi-gun Shizuoka 437-0292 JAPAN Telephone +81-538-85-0757 Facsimile +81-538-85-0456

URL:<http://www.moric-jp.com>

Welcome to the Yamaha world of motorcycling!

As the owner of the XT660R/XT660X, you are benefiting from Yamaha's vast experience and newest technology regarding the design and manufacture of high-quality products, which have earned Yamaha a reputation for dependability.

Please take the time to read this manual thoroughly, so as to enjoy all advantages of your XT660R/XT660X. The owner's manual does not only instruct you in how to operate, inspect and maintain your motorcycle, but also in how to safeguard yourself and others from trouble and injury.

In addition, the many tips given in this manual will help keep your motorcycle in the best possible condition. If you have any further questions, do not hesitate to contact your Yamaha dealer.

The Yamaha team wishes you many safe and pleasant rides. So, remember to put safety first!

# IMPORTANT MANUAL INFORMATION

---

EAU10151

Particularly important information is distinguished in this manual by the following notations:

	<b>The Safety Alert Symbol means ATTENTION! BECOME ALERT! YOUR SAFETY IS INVOLVED!</b>
	<b>Failure to follow WARNING instructions could result in severe injury or death to the motorcycle operator, a bystander, or a person inspecting or repairing the motorcycle.</b>
<b>CAUTION:</b>	<b>A CAUTION indicates special precautions that must be taken to avoid damage to the motorcycle.</b>
<b>NOTE:</b>	A NOTE provides key information to make procedures easier or clearer.

## NOTE:

- This manual should be considered a permanent part of this motorcycle and should remain with it even if the motorcycle is subsequently sold.
- Yamaha continually seeks advancements in product design and quality. Therefore, while this manual contains the most current product information available at the time of printing, there may be minor discrepancies between your motorcycle and this manual. If you have any questions concerning this manual, please consult your Yamaha dealer.

EWA10030

## WARNING

**PLEASE READ THIS MANUAL CAREFULLY AND COMPLETELY BEFORE OPERATING THIS MOTORCYCLE.**

---

\*Product and specifications are subject to change without notice.

# **IMPORTANT MANUAL INFORMATION**

---

---

EAUM1010

**XT660R/XT660X  
OWNER'S MANUAL  
©2006 by MBK INDUSTRIE  
1st edition, July 2006  
All rights reserved  
Any reprinting or unauthorized use  
without the written permission of  
MBK INDUSTRIE  
is expressly prohibited.  
Printed in France.**

# TABLE OF CONTENTS

---

<b>SAFETY INFORMATION</b> .....	1-1	<b>OPERATION AND IMPORTANT RIDING POINTS</b> .....	5-1	Checking the front and rear brake pads .....	6-22
<b>DESCRIPTION</b> .....	2-1	Starting the engine .....	5-1	Checking the brake fluid level .....	6-23
Left view .....	2-1	Shifting .....	5-2	Drive chain slack .....	6-24
Right view .....	2-2	Tips for reducing fuel consumption .....	5-3	Cleaning and lubricating the drive chain .....	6-26
Controls and instruments.....	2-3	Engine break-in .....	5-3	Checking and lubricating the cables .....	6-27
<b>INSTRUMENT AND CONTROL FUNCTIONS</b> .....	3-1	Parking .....	5-4	Checking and lubricating the throttle grip and cable .....	6-27
Immobilizer system .....	3-1	<b>PERIODIC MAINTENANCE AND MINOR REPAIR</b> .....	6-1	Checking and lubricating the brake and clutch levers .....	6-27
Main switch/steering lock .....	3-2	Owner's tool kit .....	6-1	Lubricating the brake pedal .....	6-28
Indicator and warning lights .....	3-3	Periodic maintenance and lubrication chart .....	6-2	Checking and lubricating the sidestand .....	6-28
Multi-function display .....	3-5	Removing and installing cowlings and panels .....	6-5	Checking the front fork .....	6-29
Anti-theft alarm (optional) .....	3-7	Checking the spark plug .....	6-9	Checking the steering .....	6-29
Handlebar switches .....	3-7	Engine oil and oil filter element ...	6-10	Checking the wheel bearings .....	6-30
Clutch lever .....	3-9	Coolant .....	6-13	Battery .....	6-30
Shift pedal .....	3-9	Replacing the air filter element and cleaning the check hose .....	6-16	Replacing the fuses .....	6-32
Brake lever .....	3-9	Adjusting the engine idling speed .....	6-17	Replacing the headlight bulb .....	6-33
Brake pedal .....	3-10	Checking the throttle cable free play .....	6-18	Replacing a turn signal light bulb or the tail/brake light bulb .....	6-34
Fuel tank cap .....	3-10	Tires .....	6-18	Replacing an auxiliary light bulb ..	6-35
Fuel .....	3-11	Spoke wheels .....	6-21	Supporting the motorcycle .....	6-35
Catalytic converter .....	3-12	Adjusting the clutch lever free play .....	6-21	Front wheel .....	6-36
Seat .....	3-12	Adjusting the rear brake light switch .....	6-22	Rear wheel .....	6-37
Storage compartment .....	3-13			Troubleshooting .....	6-39
Adjusting the shock absorber assembly .....	3-13			Troubleshooting charts .....	6-40
Sidestand .....	3-14				
Ignition circuit cut-off system .....	3-15				
<b>PRE-OPERATION CHECKS</b> .....	4-1				
Pre-operation check list .....	4-2				

# TABLE OF CONTENTS

---

---

## **MOTORCYCLE CARE AND**

<b>STORAGE</b> .....	7-1
Care .....	7-1
Storage .....	7-3

<b>SPECIFICATIONS</b> .....	8-1
-----------------------------	-----

<b>CONSUMER INFORMATION</b> .....	9-1
Identification numbers .....	9-1

# SAFETY INFORMATION

EAU10311

1

MOTORCYCLES ARE SINGLE TRACK VEHICLES. THEIR SAFE USE AND OPERATION ARE DEPENDENT UPON THE USE OF PROPER RIDING TECHNIQUES AS WELL AS THE EXPERTISE OF THE OPERATOR. EVERY OPERATOR SHOULD KNOW THE FOLLOWING REQUIREMENTS BEFORE RIDING THIS MOTORCYCLE.

HE OR SHE SHOULD:

- OBTAIN THOROUGH INSTRUCTIONS FROM A COMPETENT SOURCE ON ALL ASPECTS OF MOTORCYCLE OPERATION.
- OBSERVE THE WARNINGS AND MAINTENANCE REQUIREMENTS IN THE OWNER'S MANUAL.
- OBTAIN QUALIFIED TRAINING IN SAFE AND PROPER RIDING TECHNIQUES.
- OBTAIN PROFESSIONAL TECHNICAL SERVICE AS INDICATED BY THE OWNER'S MANUAL

AND/OR WHEN MADE NECESSARY BY MECHANICAL CONDITIONS.

## Safe riding

- Always make pre-operation checks. Careful checks may help prevent an accident.
- This motorcycle is designed to carry the operator and a passenger.
- The failure of motorists to detect and recognize motorcycles in traffic is the predominating cause of automobile/motorcycle accidents. Many accidents have been caused by an automobile driver who did not see the motorcycle. Making yourself conspicuous appears to be very effective in reducing the chance of this type of accident.

## Therefore:

- Wear a brightly colored jacket.
- Use extra caution when approaching and passing through intersections, since intersections are the most likely places for motorcycle accidents to occur.

- Ride where other motorists can see you. Avoid riding in another motorist's blind spot.
- Many accidents involve inexperienced operators. In fact, many operators who have been involved in accidents do not even have a current motorcycle license.
- Make sure that you are qualified and that you only lend your motorcycle to other qualified operators.
- Know your skills and limits. Staying within your limits may help you to avoid an accident.
- We recommend that you practice riding your motorcycle where there is no traffic until you have become thoroughly familiar with the motorcycle and all of its controls.
- Many accidents have been caused by error of the motorcycle operator. A typical error made by the operator is veering wide on a turn



due to EXCESSIVE SPEED or undercornering (insufficient lean angle for the speed).

- Always obey the speed limit and never travel faster than warranted by road and traffic conditions.
- Always signal before turning or changing lanes. Make sure that other motorists can see you.
- The posture of the operator and passenger is important for proper control.
  - The operator should keep both hands on the handlebar and both feet on the operator footrests during operation to maintain control of the motorcycle.
  - The passenger should always hold onto the operator, the seat strap or grab bar, if equipped, with both hands and keep both feet on the passenger footrests.
  - Never carry a passenger unless he or she can firmly place both feet on the passenger footrests.
- Never ride under the influence of alcohol or other drugs.

### Protective apparel

The majority of fatalities from motorcycle accidents are the result of head injuries. The use of a safety helmet is the single most critical factor in the prevention or reduction of head injuries.

- Always wear an approved helmet.
- Wear a face shield or goggles. Wind in your unprotected eyes could contribute to an impairment of vision that could delay seeing a hazard.
- The use of a jacket, heavy boots, trousers, gloves, etc., is effective in preventing or reducing abrasions or lacerations.
- Never wear loose-fitting clothes, otherwise they could catch on the control levers, footrests, or wheels and cause injury or an accident.
- Never touch the engine or exhaust system during or after operation. They become very hot and can cause burns. Always wear protective clothing that covers your legs, ankles, and feet.
- Passengers should also observe the precautions mentioned above.

### Modifications

Modifications made to this motorcycle not approved by Yamaha, or the removal of original equipment, may render the motorcycle unsafe for use and may cause severe personal injury. Modifications may also make your motorcycle illegal to use.

### Loading and accessories

Adding accessories or cargo to your motorcycle can adversely affect stability and handling if the weight distribution of the motorcycle is changed. To avoid the possibility of an accident, use extreme caution when adding cargo or accessories to your motorcycle. Use extra care when riding a motorcycle that has added cargo or accessories. Here are some general guidelines to follow if loading cargo or adding accessories to your motorcycle:

#### Loading

The total weight of the operator, passenger, accessories and cargo must not exceed the maximum load limit.

<b>Maximum load:</b> 186 kg (410 lb)
---

# SAFETY INFORMATION

---

When loading within this weight limit, keep the following in mind:

- Cargo and accessory weight should be kept as low and close to the motorcycle as possible. Make sure to distribute the weight as evenly as possible on both sides of the motorcycle to minimize imbalance or instability.
- Shifting weights can create a sudden imbalance. Make sure that accessories and cargo are securely attached to the motorcycle before riding. Check accessory mounts and cargo restraints frequently.
- Never attach any large or heavy items to the handlebar, front fork, or front fender. These items, including such cargo as sleeping bags, duffel bags, or tents, can create unstable handling or a slow steering response.

## Accessories

Genuine Yamaha accessories have been specifically designed for use on this motorcycle. Since Yamaha cannot test all other accessories that may be available, you must personally be responsible for the proper selection, in-

stallation and use of non-Yamaha accessories. Use extreme caution when selecting and installing any accessories.

Keep the following guidelines in mind, as well as those provided under “Loading” when mounting accessories.

- Never install accessories or carry cargo that would impair the performance of your motorcycle. Carefully inspect the accessory before using it to make sure that it does not in any way reduce ground clearance or cornering clearance, limit suspension travel, steering travel or control operation, or obscure lights or reflectors.
- Accessories fitted to the handlebar or the front fork area can create instability due to improper weight distribution or aerodynamic changes. If accessories are added to the handlebar or front fork area, they must be as lightweight as possible and should be kept to a minimum.
- Bulky or large accessories may seriously affect the stability of the motorcycle due to aerody-

dynamic effects. Wind may attempt to lift the motorcycle, or the motorcycle may become unstable in cross winds. These accessories may also cause instability when passing or being passed by large vehicles.

- Certain accessories can displace the operator from his or her normal riding position. This improper position limits the freedom of movement of the operator and may limit control ability, therefore, such accessories are not recommended.
- Use caution when adding electrical accessories. If electrical accessories exceed the capacity of the motorcycle’s electrical system, an electric failure could result, which could cause a dangerous loss of lights or engine power.

## **Gasoline and exhaust gas**

- **GASOLINE IS HIGHLY FLAMMABLE:**
  - Always turn the engine off when refueling.

- Take care not to spill any gasoline on the engine or exhaust system when refueling.
- Never refuel while smoking or in the vicinity of an open flame.
- Never start the engine or let it run for any length of time in a closed area. The exhaust fumes are poisonous and may cause loss of consciousness and death within a short time. Always operate your motorcycle in an area that has adequate ventilation.
- Always turn the engine off before leaving the motorcycle unattended and remove the key from the main switch. When parking the motorcycle, note the following:
  - The engine and exhaust system may be hot, therefore, park the motorcycle in a place where pedestrians or children are not likely to touch these hot areas.
  - Do not park the motorcycle on a slope or soft ground, otherwise it may fall over.
- Do not park the motorcycle near a flammable source (e.g., a kerosene heater, or near an open flame), otherwise it could catch fire.
- When transporting the motorcycle in another vehicle, make sure that it is kept upright and that the fuel cock(s) are turned to “ON” or “RES” (for vacuum type)/“OFF” (for manual type). If the motorcycle should lean over, gasoline may leak out of the carburetor or fuel tank.
- If you should swallow any gasoline, inhale a lot of gasoline vapor, or allow gasoline to get into your eyes, see your doctor immediately. If any gasoline spills on your skin or clothing, immediately wash the affected area with soap and water and change your clothes.

# DESCRIPTION

EAU10410

## Left view

2

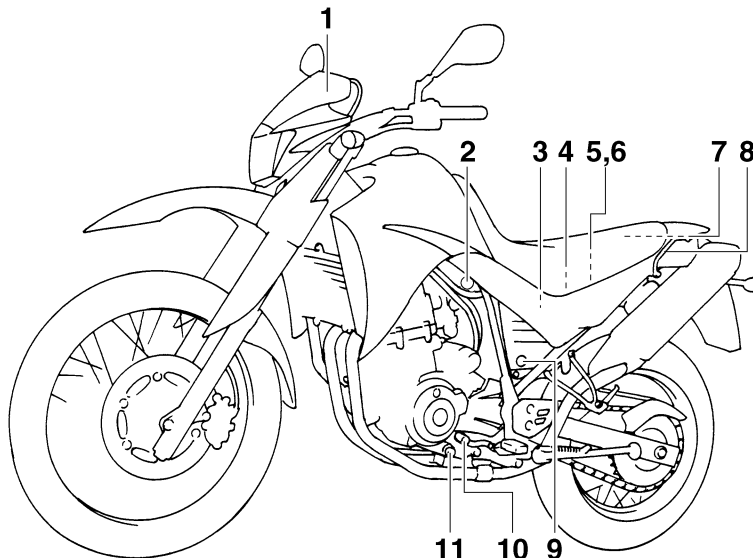

1. Windshield
2. Idle adjusting screw (page 6-17)
3. Main fuse (page 6-32)
4. Battery (page 6-30)
5. Fuse box 1 (page 6-32)
6. Fuse box 2 (page 6-32)
7. Storage compartment (page 3-13)
8. Grab bar

9. Seat lock (page 3-12 )
10. Shift pedal (page 3-9)
11. Engine oil drain bolt (crankcase) (page 6-10)

## Right view

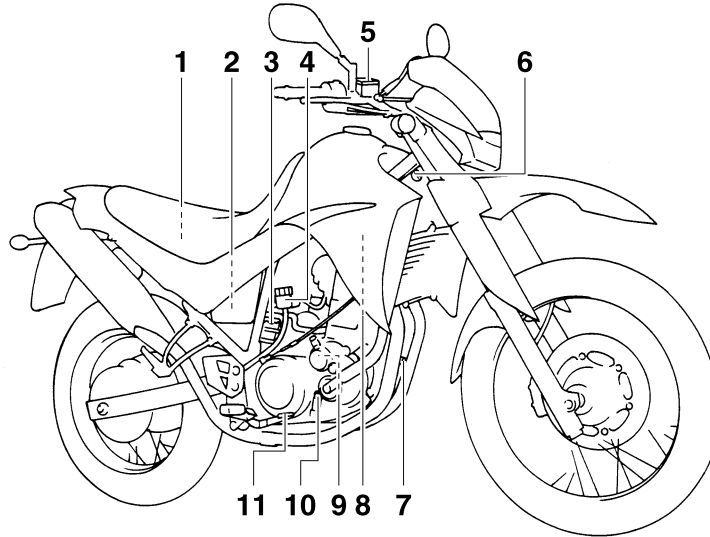

1. Owner's tool kit (page 6-1)
2. Air filter element (page 6-16)
3. Shock absorber assembly spring preload adjusting ring (page 3-13)
4. Rear brake fluid reservoir (page 6-23)
5. Front brake fluid reservoir (page 6-23)
6. Engine oil filler cap (page 6-10)
7. Engine oil drain bolt (oil tank) (page 6-10)
8. Coolant reservoir (page 6-13)
9. Engine oil filter element (page 6-10)
10. Coolant drain bolt (page 6-14)
11. Brake pedal (page 3-10)

# DESCRIPTION

EAU32240

## Controls and instruments

XT660R

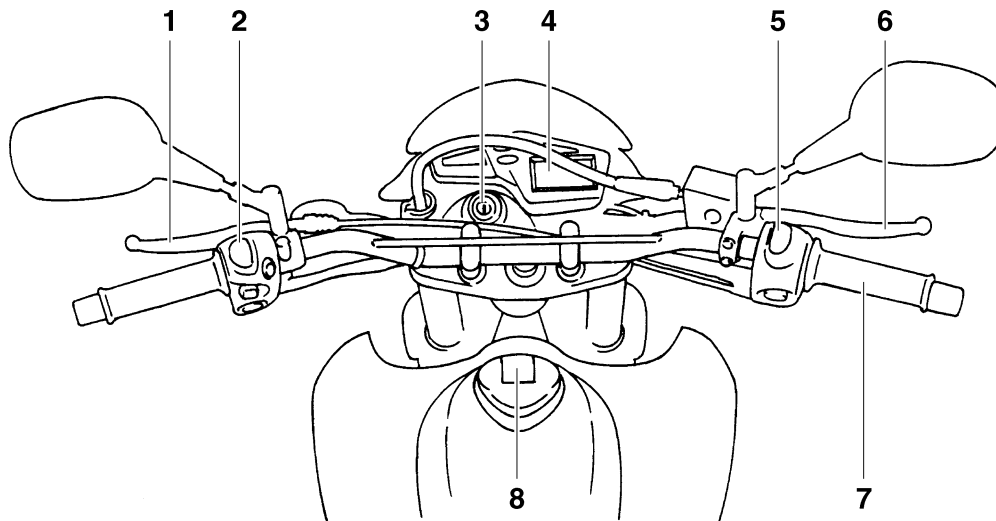

- 1. Clutch lever (page 3-9)
- 2. Left handlebar switches (page 3-7)
- 3. Main switch/steering lock (page 3-2)
- 4. Multi-function display (page 3-5)
- 5. Right handlebar switches (page 3-7)
- 6. Brake lever (page 3-9)
- 7. Throttle grip (page 6-18)

- 8. Fuel tank cap (page 3-10)

## XT660X

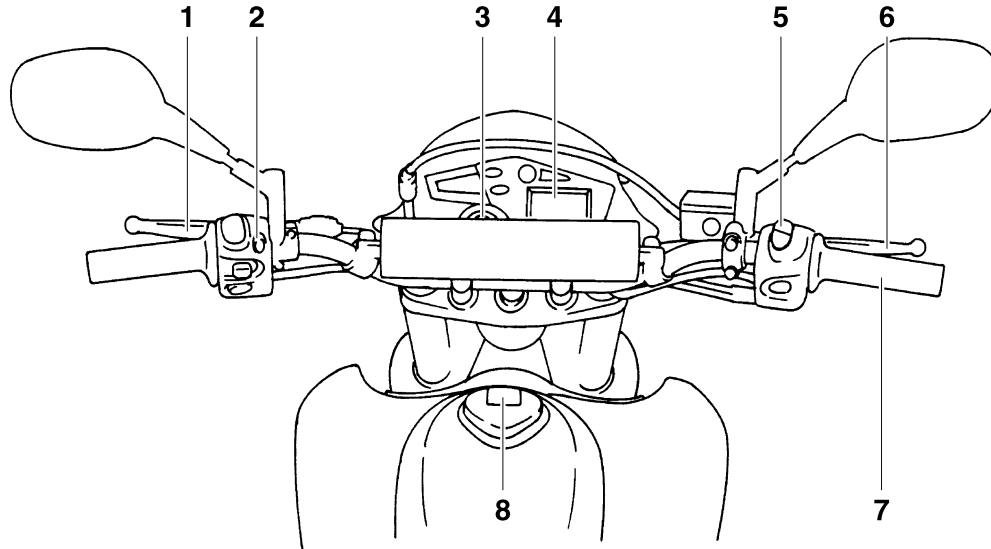

1. Clutch lever (page 3-9)
2. Left handlebar switches (page 3-7)
3. Main switch/steering lock (page 3-2)
4. Multi-function display (page 3-5)
5. Right handlebar switches (page 3-7)
6. Brake lever (page 3-9)
7. Throttle grip (page 6-18)
8. Fuel tank cap (page 3-10)

# INSTRUMENT AND CONTROL FUNCTIONS

## Immobilizer system

EAU10972

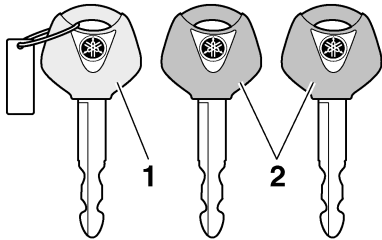

1. Code re-registering key (red bow)
2. Standard keys (black bow)

This vehicle is equipped with an immobilizer system to help prevent theft by re-registering codes in the standard keys. This system consists of the following.

- a code re-registering key (with a red bow)
- two standard keys (with a black bow) that can be re-registered with new codes
- a transponder (which is installed in the code re-registering key)
- an immobilizer unit
- an ECU

- an immobilizer system indicator light (See page 3-3.)

The key with the red bow is used to register codes in each standard key. Since re-registering is a difficult process, take the vehicle along with all three keys to a Yamaha dealer to have them re-registered. Do not use the key with the red bow for driving. It should only be used for re-registering the standard keys. Always use a standard key for driving.

ECA11820

### CAUTION:

- **DO NOT LOSE THE CODE RE-REGISTERING KEY! CONTACT YOUR DEALER IMMEDIATELY IF IT IS LOST!** If the code re-registering key is lost, registering new codes in the standard keys is impossible. The standard keys can still be used to start the vehicle, however if code re-registering is required (i.e., if a new standard key is made or all keys are lost) the entire immobilizer system must be replaced. Therefore, it is highly recom-

mended to use either standard key and keep the code re-registering key in a safe place.

- Do not submerge any key in water.
- Do not expose any key to excessively high temperatures.
- Do not place any key close to magnets (this includes, but not limited to, products such as speakers, etc.).
- Do not place heavy items on any key.
- Do not grind any key or alter its shape.
- Do not disassemble the plastic part of any key.
- Do not put two keys of any immobilizer system on the same key ring.
- Keep the standard keys as well as keys of other immobilizer systems away from this vehicle's code re-registering key.
- Keep other immobilizer system keys away from the main switch as they may cause signal interference.



## Main switch/steering lock

EAU10471

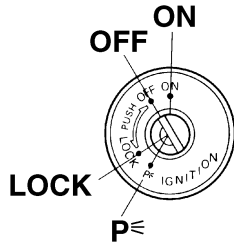

The main switch/steering lock controls the ignition and lighting systems, and is used to lock the steering.

**NOTE:** \_\_\_\_\_  
Be sure to use the standard key (black bow) for regular use of the vehicle. To minimize the risk of losing the code registering key (red bow), keep it in a safe place and only use it for code registering.

### ON

EAU10570

All electrical circuits are supplied with power; the meter lighting, taillight and auxiliary light come on, and the engine can be started. The key cannot be removed.

**NOTE:** \_\_\_\_\_  
The headlight comes on automatically when the engine is started and stays on until the key is turned to "OFF".

### OFF

EAU10660

All electrical systems are off. The key can be removed.

### LOCK

EAU10680

The steering is locked, and all electrical systems are off. The key can be removed.

## To lock the steering

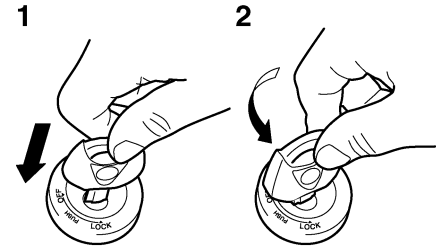

1. Push.
2. Turn.

1. Turn the handlebars all the way to the left.
2. Push the key in from the "OFF" position, and then turn it to "LOCK" while still pushing it.
3. Remove the key.

# INSTRUMENT AND CONTROL FUNCTIONS

## To unlock the steering

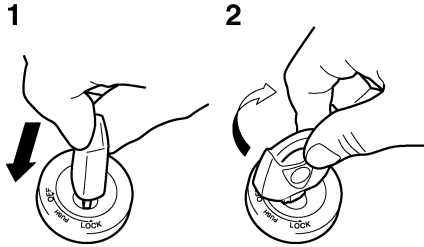

1. Push.
2. Turn.

Push the key in, and then turn it to “OFF” while still pushing it.

EWA10060

### **! WARNING**

Never turn the key to “OFF” or “LOCK” while the vehicle is moving, otherwise the electrical systems will be switched off, which may result in loss of control or an accident. Make sure that the vehicle is stopped before turning the key to “OFF” or “LOCK”.

## p< (Parking)

EAU33001

The steering is locked, and the taillight and auxiliary light are on. The hazard lights and turn signal lights can be turned on, but all other electrical systems are off. The key can be removed. The steering must be locked before the key can be turned to “p<”.

ECA11020

### **CAUTION:**

**Do not use the parking position for an extended length of time, otherwise the battery may discharge.**

## Indicator and warning lights

EAU11003

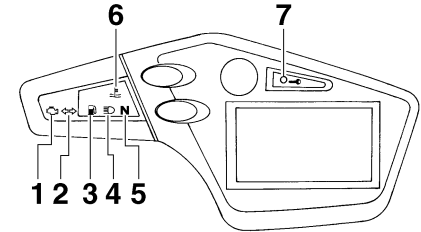

1. Engine trouble warning light “”
2. Turn signal indicator light “ ”
3. Fuel level warning light “”
4. High beam indicator light “”
5. Neutral indicator light “**N**”
6. Coolant temperature warning light “”
7. Immobilizer system indicator light “”

### Turn signal indicator light “ ”

EAU11020

This indicator light flashes when the turn signal switch is pushed to the left or right.

### Neutral indicator light “**N**”

EAU11060

This indicator light comes on when the transmission is in the neutral position.

**High beam indicator light** “”<sup>EAU11080</sup>  
This indicator light comes on when the high beam of the headlight is switched on.

**Fuel level warning light** “”<sup>EAU11361</sup>  
This warning light comes on when the fuel level drops below approximately 5.0 L (1.32 US gal) (1.10 Imp.gal). When this occurs, refuel as soon as possible.  
The electrical circuit of the warning light can be checked by turning the key to “ON”.  
If the warning light does not come on for a few seconds, and then go off, have a Yamaha dealer check the electrical circuit.

**NOTE:** \_\_\_\_\_  
This model is also equipped with a self-diagnosis device for the fuel level detection circuit. If the fuel level detection circuit is defective, the following cycle will be repeated until the malfunction is corrected: The fuel level warning light

will flash eight times, and then go off for 3.0 seconds. If this occurs, have a Yamaha dealer check the vehicle.

**Coolant temperature warning light** “”<sup>EAU11440</sup>

This warning light comes on when the engine overheats. When this occurs, stop the engine immediately and allow the engine to cool.  
The electrical circuit of the warning light can be checked by turning the key to “ON”.  
If the warning light does not come on for a few seconds, then go off, have a Yamaha dealer check the electrical circuit.

**CAUTION:** \_\_\_\_\_

**Do not operate the engine if it is overheated.**

**Engine trouble warning light** “”<sup>EAU11530</sup>

This warning light comes on or flashes when an electrical circuit monitoring the engine is defective. When this occurs, have a Yamaha dealer check the self-

diagnosis system. (See page 3-5 for an explanation of the self-diagnosis device.)

The electrical circuit of the warning light can be checked by turning the key to “ON”. If the warning light does not come on for a few seconds, then go off, have a Yamaha dealer check the electrical circuit.

**Immobilizer system indicator light** “”<sup>EAU26873</sup>

The electrical circuit of the indicator light can be checked by turning the key to “ON”.  
If the indicator light does not come on for a few seconds, then go off, have a Yamaha dealer check the electrical circuit.

When the key is turned to “OFF” and 30 seconds have passed, the indicator light will start flashing indicating the immobilizer system is enabled. After 24 hours have passed, the indicator light will stop flashing, however the immobilizer system is still enabled.

# INSTRUMENT AND CONTROL FUNCTIONS

This model is also equipped with a self-diagnosis device for the immobilizer system. (See page 3-5 for an explanation of the self-diagnosis device.)

## Multi-function display

EAM1662

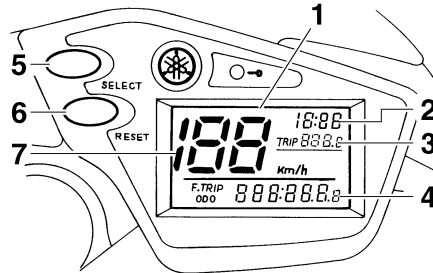

1. Multi-function display
2. Clock
3. Tripmeter 1
4. Odometer/fuel reserve tripmeter/tripmeter 2
5. "SELECT" button
6. "RESET" button
7. Speedometer

The multi-function display is equipped with the following:

- a speedometer (which shows the riding speed)
- an odometer (which shows the total distance traveled)
- two tripmeters (which show the distance traveled since they were last set to zero)

- a fuel reserve tripmeter (which shows the distance traveled since the fuel level warning light came on)
- a clock
- a self-diagnosis device

### NOTE:

- Be sure to turn the key to "ON" before using the "SELECT" and "RESET" buttons.
- For the U.K. only: To switch the speedometer and odometer/tripmeter displays between kilometers and miles, press the "SELECT" button for at least two seconds.

### Odometer and tripmeter modes

Pushing the "SELECT" button switches the display between the odometer mode "ODO" and the tripmeter modes "TRIP 1" and "TRIP 2" in the following order:

ODO → TRIP 1 → TRIP 2 → ODO

If the fuel level warning light comes on (see page 3-3), the odometer display will automatically change to the fuel reserve tripmeter mode "F-TRIP" and start counting the distance traveled

# INSTRUMENT AND CONTROL FUNCTIONS

from that point. In that case, pushing the “SELECT” button switches the display between the various tripmeter and odometer modes in the following order: F-TRIP → TRIP 1 → TRIP 2 → ODO → F-TRIP

To reset a tripmeter, select it by pushing the “SELECT” button, and then push the “RESET” button for at least one second while the selected tripmeter is flashing. If you do not reset the fuel reserve tripmeter manually, it will reset itself automatically and the display will return to the prior mode after refueling and traveling 5 km (3 mi).

## Clock mode

Turn the key to “ON”.

### To set the clock:

1. Push the “SELECT” button and “RESET” button together for at least two seconds.
2. When the hour digits start flashing, push the “RESET” button to set the hours.
3. Push the “SELECT” button to fix the hours, and the minute digits will start flashing.

4. Push the “RESET” button to set the minutes.
5. Push the “SELECT” button to fix the minutes, and then release it to start the clock.

## Self-diagnosis device

This model is equipped with a self-diagnosis device for various electrical circuits.

If any of those circuits are defective, the engine trouble warning light will come on, and then the multi-function display will indicate a two-digit error code (e.g., 11, 12, 13).

If the multi-function display indicates such an error code, note the code number, and then have a Yamaha dealer check the vehicle.

ECA11590

## CAUTION:

**If the display indicates an error code, the vehicle should be checked as soon as possible in order to avoid engine damage.**

This model is also equipped with a self-diagnosis device for the immobilizer system.

If any of the immobilizer system circuits are defective, the immobilizer system indicator light will flash, and then the multi-function display will indicate a two-digit error code (e.g., 51, 52, 53) when the key is turned to “ON”.

## NOTE:

If the multi-function display indicates error code 52, this could be caused by transponder interference. If this error appears, try the following.

1. Use the code re-registering key to start the engine.

## NOTE:

Make sure there are no other immobilizer keys close to the main switch, and do not keep more than one immobilizer key on the same key ring! Immobilizer system keys may cause signal interference, which may prevent the engine from starting.

2. If the engine starts, turn it off, and try starting the engine with the standard keys.
3. If one or both of the standard keys do not start the engine, take the vehicle, the code re-registering

# INSTRUMENT AND CONTROL FUNCTIONS

key and both standard keys to a Yamaha dealer and have the standard keys re-registered.

If the multi-function display indicates any error codes, note the code number, and then have a Yamaha dealer check the vehicle.

3

## Anti-theft alarm (optional)

EAU12331

This model can be equipped with an optional anti-theft alarm by a Yamaha dealer. Contact a Yamaha dealer for more information.

## Handlebar switches

EAU12347

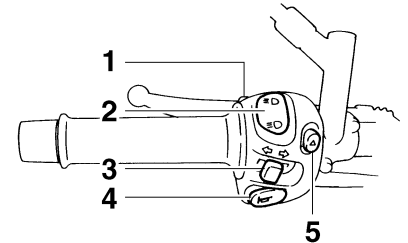

Left

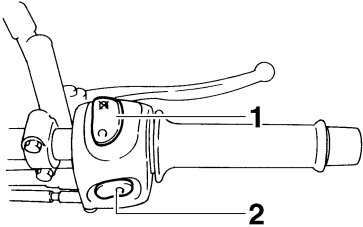

1. Pass switch “≡○”
2. Dimmer switch “≡○/≡○”
3. Turn signal switch “←/→”
4. Horn switch “🔊”
5. Hazard switch “△”

## Right



1. Engine stop switch “/”
2. Start switch “”



EAU12350

### Pass switch “”

Press this switch to flash the headlight.



EAU12400

### Dimmer switch “/”

Set this switch to “” for the high beam and to “” for the low beam.

EAU12460

### Turn signal switch “/”

To signal a right-hand turn, push this switch to “”. To signal a left-hand turn, push this switch to “”. When released, the switch returns to the center

position. To cancel the turn signal lights, push the switch in after it has returned to the center position.



EAU12500

### Horn switch “”

Press this switch to sound the horn.

EAU12660

### Engine stop switch “/”

Set this switch to “” before starting the engine. Set this switch to “” to stop the engine in case of an emergency, such as when the vehicle overturns or when the throttle cable is stuck.

EAU12710

### Start switch “”

Push this switch to crank the engine with the starter.

ECA10050

### CAUTION:

**See page 5-1 for starting instructions prior to starting the engine.**

EAU12733

### Hazard switch “”

With the key in the “ON” or “P<” position, use this switch to turn on the hazard lights (simultaneous flashing of all turn signal lights).

The hazard lights are used in case of an emergency or to warn other drivers when your vehicle is stopped where it might be a traffic hazard.

ECA10061

### CAUTION:

**Do not use the hazard lights for an extended length of time with the engine not running, otherwise the battery may discharge.**

# INSTRUMENT AND CONTROL FUNCTIONS

## Clutch lever

EAU12820

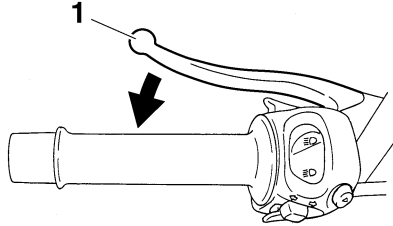

### 1. Clutch lever

The clutch lever is located at the left handlebar grip. To disengage the clutch, pull the lever toward the handlebar grip. To engage the clutch, release the lever. The lever should be pulled rapidly and released slowly for smooth clutch operation.

The clutch lever is equipped with a clutch switch, which is part of the ignition circuit cut-off system. (See page 3-15.)

## Shift pedal

EAU12870

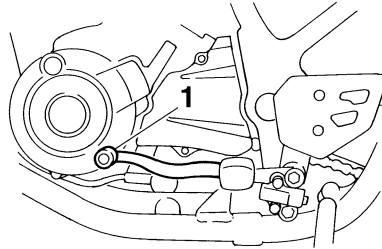

### 1. Shift pedal

The shift pedal is located on the left side of the engine and is used in combination with the clutch lever when shifting the gears of the 5-speed constant-mesh transmission equipped on this motorcycle.

## Brake lever

EAU12890

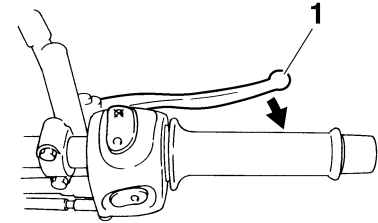

### 1. Brake lever

The brake lever is located at the right handlebar grip. To apply the front brake, pull the lever toward the handlebar grip.



# INSTRUMENT AND CONTROL FUNCTIONS

## Brake pedal

EAU12941

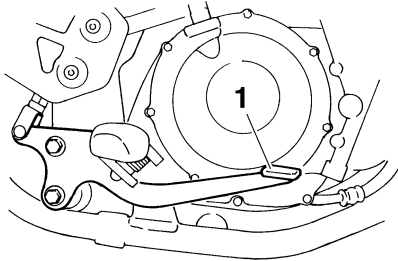

1. Brake pedal

The brake pedal is on the right side of the motorcycle. To apply the rear brake, press down on the brake pedal.

## Fuel tank cap

EAUM1791

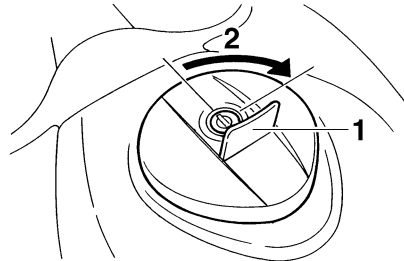

1. Fuel tank cap lock cover
2. Unlock.

### To remove the fuel tank cap

1. Open the fuel tank cap lock cover.
2. Insert the key into the lock and turn it 1/4 turn clockwise. The lock will be released and the fuel tank cap can be removed.

### To install the fuel tank cap

1. Push and install the fuel tank cap into position with the key inserted in the lock.
2. Turn the key counterclockwise to the original position, and then remove it.

### NOTE: \_\_\_\_\_

The fuel tank cap cannot be installed unless the key is in the lock. In addition, the key cannot be removed if the cap is not properly installed and locked.

EWA11140



**WARNING** \_\_\_\_\_

**Make sure that the fuel tank cap is properly installed before riding.**

# INSTRUMENT AND CONTROL FUNCTIONS

## Fuel

EAU13211

ECA10070

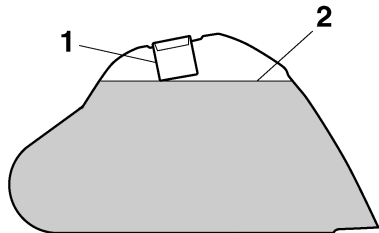

3

1. Fuel tank filler tube
2. Fuel level

Make sure that there is sufficient fuel in the tank. Fill the fuel tank to the bottom of the filler tube as shown.

EWA10880

### **⚠ WARNING**

- Do not overfill the fuel tank, otherwise it may overflow when the fuel warms up and expands.
- Avoid spilling fuel on the hot engine.

### **CAUTION:**

Immediately wipe off spilled fuel with a clean, dry, soft cloth, since fuel may deteriorate painted surfaces or plastic parts.

EAU13390

### **Recommended fuel:**

PREMIUM UNLEADED GASOLINE ONLY

### **Fuel tank capacity:**

15.0 L (3.96 US gal) (3.30 Imp.gal)

### **Fuel reserve amount (when the fuel level warning light comes on):**

5.0 L (1.32 US gal) (1.10 Imp.gal)

ECA11400

### **CAUTION:**

Use only unleaded gasoline. The use of leaded gasoline will cause severe damage to internal engine parts, such as the valves and piston rings, as well as to the exhaust system.

Your Yamaha engine has been designed to use premium unleaded gasoline with a research octane number of 95 or higher. If knocking (or pinging) oc-

curs, use a gasoline of a different brand. Use of unleaded fuel will extend spark plug life and reduce maintenance costs.

# INSTRUMENT AND CONTROL FUNCTIONS

## Catalytic converter

EAU13431

This model is equipped with a catalytic converter in the exhaust system.

EWA10860

### **WARNING**

The exhaust system is hot after operation. Make sure that the exhaust system has cooled down before doing any maintenance work.

ECA10700

### **CAUTION:**

The following precautions must be observed to prevent a fire hazard or other damages.

- Use only unleaded gasoline. The use of leaded gasoline will cause unreparable damage to the catalytic converter.
- Never park the vehicle near possible fire hazards such as grass or other materials that easily burn.
- Do not allow the engine to idle too long.

## Seat

EAU13900

### To remove the seat

1. Insert the key into the seat lock, and then turn it as shown.

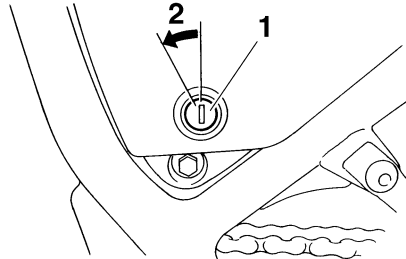

1. Seat lock
2. Unlock.

2. Pull the seat off.

### To install the seat

1. Insert the projection on the front of the seat into the seat holder as shown.

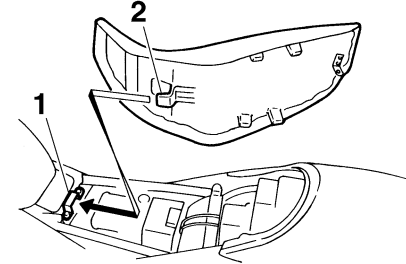

1. Seat holder
2. Projection

2. Push the rear of the seat down to lock it in place.
3. Remove the key.

### **NOTE:**

Make sure that the seat is properly secured before riding.

# INSTRUMENT AND CONTROL FUNCTIONS

## Storage compartment

EAU14422

- Do not exceed the maximum load of 186 kg (410 lb) for the vehicle.

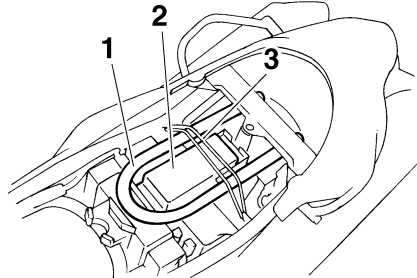

1. CYCLELOK bar (optional)
2. Yamaha CYCLELOK (optional)
3. Strap

This storage compartment is designed to hold a genuine Yamaha CYCLELOK. (Other locks may not fit.) When placing a CYCLELOK in the storage compartment, securely fasten it with the straps. When the CYCLELOK is not in the storage compartment, be sure to secure the straps to prevent losing them.

EWA10961

### **WARNING**

- Do not exceed the load limit of 3 kg (7 lb) for the storage compartment.

## Adjusting the shock absorber assembly

EAU14830

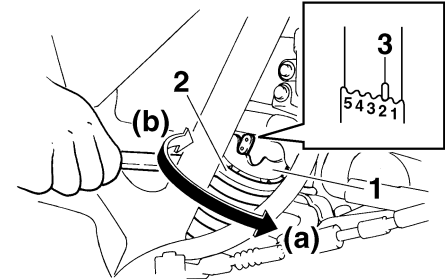

1. Spring preload adjusting ring
2. Special wrench
3. Position indicator

This shock absorber assembly is equipped with a spring preload adjusting ring.

ECA10100

### **CAUTION:**

**Never attempt to turn an adjusting mechanism beyond the maximum or minimum settings.**

Adjust the spring preload as follows. To increase the spring preload and thereby harden the suspension, turn the adjusting ring in direction (a). To de-

crease the spring preload and thereby soften the suspension, turn the adjusting ring in direction (b).

**NOTE:** \_\_\_\_\_

Align the appropriate notch in the adjusting ring with the position indicator on the shock absorber.

**Spring preload setting:**

- Minimum (soft):  
1
- Standard:  
2
- Maximum (hard):  
5

EWA10220

 **WARNING** \_\_\_\_\_

This shock absorber contains highly pressurized nitrogen gas. For proper handling, read and understand the following information before handling the shock absorber. The manufacturer cannot be held responsible for property damage or personal injury that may result from improper handling.

- Do not tamper with or attempt to open the gas cylinder.

- Do not subject the shock absorber to an open flame or other high heat sources, otherwise it may explode due to excessive gas pressure.
- Do not deform or damage the gas cylinder in any way, as this will result in poor damping performance.
- Always have a Yamaha dealer service the shock absorber.

## Sidestand

The sidestand is located on the left side of the frame. Raise the sidestand or lower it with your foot while holding the vehicle upright.

**NOTE:** \_\_\_\_\_

The built-in sidestand switch is part of the ignition circuit cut-off system, which cuts the ignition in certain situations. (See further down for an explanation of the ignition circuit cut-off system.)

EWA10240

 **WARNING** \_\_\_\_\_

The vehicle must not be ridden with the sidestand down, or if the sidestand cannot be properly moved up (or does not stay up), otherwise the sidestand could contact the ground and distract the operator, resulting in a possible loss of control. Yamaha's ignition circuit cut-off system has been designed to assist the operator in fulfilling the responsibility of raising the sidestand before starting off. Therefore, check this system regularly as described

# INSTRUMENT AND CONTROL FUNCTIONS

---

below and have a Yamaha dealer repair it if it does not function properly.

---

3

EAU15311

## Ignition circuit cut-off system

The ignition circuit cut-off system (comprising the sidestand switch, clutch switch and neutral switch) has the following functions.

- It prevents starting when the transmission is in gear and the sidestand is up, but the clutch lever is not pulled.
- It prevents starting when the transmission is in gear and the clutch lever is pulled, but the sidestand is still down.
- It cuts the running engine when the transmission is in gear and the sidestand is moved down.

Periodically check the operation of the ignition circuit cut-off system according to the following procedure.

EWA10250



**If a malfunction is noted, have a Yamaha dealer check the system before riding.**

---

# INSTRUMENT AND CONTROL FUNCTIONS

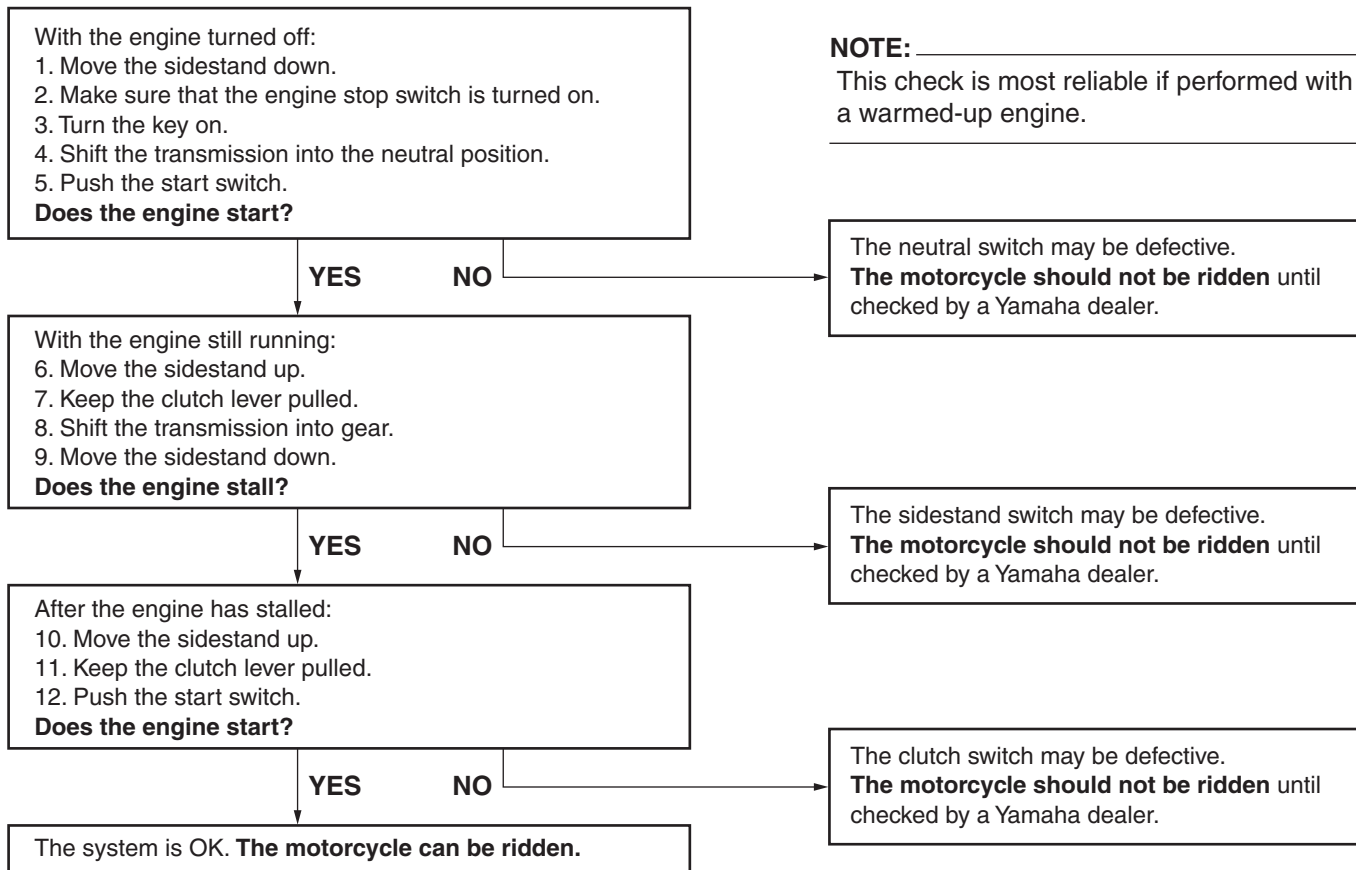

# PRE-OPERATION CHECKS

---

---

EAU15591

The condition of a vehicle is the owner's responsibility. Vital components can start to deteriorate quickly and unexpectedly, even if the vehicle remains unused (for example, as a result of exposure to the elements). Any damage, fluid leakage or loss of tire air pressure could have serious consequences. Therefore, it is very important, in addition to a thorough visual inspection, to check the following points before each ride.

## NOTE:

Pre-operation checks should be made each time the vehicle is used. Such an inspection can be accomplished in a very short time; and the added safety it assures is more than worth the time involved.

EWA11150

4



**If any item in the Pre-operation check list is not working properly, have it inspected and repaired before operating the vehicle.**

---



# PRE-OPERATION CHECKS

EAU15605

## Pre-operation check list

ITEM	CHECKS	PAGE
<b>Fuel</b>	<ul style="list-style-type: none"><li>• Check fuel level in fuel tank.</li><li>• Refuel if necessary.</li><li>• Check fuel line for leakage.</li></ul>	3-11
<b>Engine oil</b>	<ul style="list-style-type: none"><li>• Check oil level in oil tank.</li><li>• If necessary, add recommended oil to specified level.</li><li>• Check vehicle for oil leakage.</li></ul>	6-10
<b>Coolant</b>	<ul style="list-style-type: none"><li>• Check coolant level in reservoir.</li><li>• If necessary, add recommended coolant to specified level.</li><li>• Check cooling system for leakage.</li></ul>	6-13
<b>Front brake</b>	<ul style="list-style-type: none"><li>• Check operation.</li><li>• If soft or spongy, have Yamaha dealer bleed hydraulic system.</li><li>• Check brake pads for wear.</li><li>• Replace if necessary.</li><li>• Check fluid level in reservoir.</li><li>• If necessary, add recommended brake fluid to specified level.</li><li>• Check hydraulic system for leakage.</li></ul>	6-22, 6-23
<b>Rear brake</b>	<ul style="list-style-type: none"><li>• Check operation.</li><li>• If soft or spongy, have Yamaha dealer bleed hydraulic system.</li><li>• Check brake pads for wear.</li><li>• Replace if necessary.</li><li>• Check fluid level in reservoir.</li><li>• If necessary, add recommended brake fluid to specified level.</li><li>• Check hydraulic system for leakage.</li></ul>	6-22, 6-23
<b>Clutch</b>	<ul style="list-style-type: none"><li>• Check operation.</li><li>• Lubricate cable if necessary.</li><li>• Check lever free play.</li><li>• Adjust if necessary.</li></ul>	6-21

# PRE-OPERATION CHECKS

ITEM	CHECKS	PAGE
<b>Throttle grip</b>	<ul style="list-style-type: none"> <li>• Make sure that operation is smooth.</li> <li>• Check cable free play.</li> <li>• If necessary, have Yamaha dealer adjust cable free play and lubricate cable and grip housing.</li> </ul>	6-18, 6-27
<b>Control cables</b>	<ul style="list-style-type: none"> <li>• Make sure that operation is smooth.</li> <li>• Lubricate if necessary.</li> </ul>	6-27
<b>Drive chain</b>	<ul style="list-style-type: none"> <li>• Check chain slack.</li> <li>• Adjust if necessary.</li> <li>• Check chain condition.</li> <li>• Lubricate if necessary.</li> </ul>	6-24, 6-26
<b>Wheels and tires</b>	<ul style="list-style-type: none"> <li>• Check for damage.</li> <li>• Check tire condition and tread depth.</li> <li>• Check air pressure.</li> <li>• Correct if necessary.</li> </ul>	6-18, 6-21
<b>Brake pedal</b>	<ul style="list-style-type: none"> <li>• Make sure that operation is smooth.</li> <li>• Lubricate pedal pivoting point if necessary.</li> </ul>	6-28
<b>Brake and clutch levers</b>	<ul style="list-style-type: none"> <li>• Make sure that operation is smooth.</li> <li>• Lubricate lever pivoting points if necessary.</li> </ul>	6-27
<b>Sidestand</b>	<ul style="list-style-type: none"> <li>• Make sure that operation is smooth.</li> <li>• Lubricate pivot if necessary.</li> </ul>	6-28
<b>Chassis fasteners</b>	<ul style="list-style-type: none"> <li>• Make sure that all nuts, bolts and screws are properly tightened.</li> <li>• Tighten if necessary.</li> </ul>	—
<b>Instruments, lights, signals and switches</b>	<ul style="list-style-type: none"> <li>• Check operation.</li> <li>• Correct if necessary.</li> </ul>	—
<b>Sidestand switch</b>	<ul style="list-style-type: none"> <li>• Check operation of ignition circuit cut-off system.</li> <li>• If system is defective, have Yamaha dealer check vehicle.</li> </ul>	3-14

# OPERATION AND IMPORTANT RIDING POINTS

EAU15950

EWA10270

## **WARNING**

- Become thoroughly familiar with all operating controls and their functions before riding. Consult a Yamaha dealer regarding any control or function that you do not thoroughly understand.
- Never start the engine or operate it in a closed area for any length of time. Exhaust fumes are poisonous, and inhaling them can cause loss of consciousness and death within a short time. Always make sure that there is adequate ventilation.
- Before starting out, make sure that the sidestand is up. If the sidestand is not raised completely, it could contact the ground and distract the operator, resulting in a possible loss of control.

## Starting the engine

In order for the ignition circuit cut-off system to enable starting, one of the following conditions must be met:

- The transmission is in the neutral position.
- The transmission is in gear with the clutch lever pulled and the sidestand up.

EAM1670

## **WARNING**

- Before starting the engine, check the function of the ignition circuit cut-off system according to the procedure described on page 3-15.
- Never ride with the sidestand down.

EWA10290

1. Turn the key to "ON" and make sure that the engine stop switch is set to "○".

ECAM1030

## **CAUTION:**

The following warning lights and indicator light should come on for a few seconds, then go off.

- Fuel level warning light

- Coolant temperature warning light
- Engine trouble warning light
- Immobilizer system indicator light

If a warning or indicator light does not go off, see page 3-3 for the corresponding warning and indicator light circuit check.

2. Shift the transmission into the neutral position.

## **NOTE:**

When the transmission is in the neutral position, the neutral indicator light should be on, otherwise have a Yamaha dealer check the electrical circuit.

3. Start the engine by pushing the start switch.

## **NOTE:**

If the engine fails to start, release the start switch, wait a few seconds, and then try again. Each starting attempt should be as short as possible to pre-

# OPERATION AND IMPORTANT RIDING POINTS

serve the battery. Do not crank the engine more than 10 seconds on any one attempt.

ECA11040

## CAUTION:

For maximum engine life, never accelerate hard when the engine is cold!

## NOTE:

The engine is warm when it quickly responds to the throttle.

5

## Shifting

EAU16671

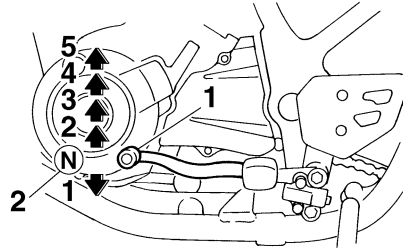

1. Shift pedal
2. Neutral position

Shifting gears lets you control the amount of engine power available for starting off, accelerating, climbing hills, etc.

The gear positions are shown in the illustration.

## NOTE:

To shift the transmission into the neutral position, press the shift pedal repeatedly until it reaches the end of its travel, and then slightly raise it.

ECA10260

## CAUTION:

- Even with the transmission in the neutral position, do not coast for long periods of time with the engine off, and do not tow the motorcycle for long distances. The transmission is properly lubricated only when the engine is running. Inadequate lubrication may damage the transmission.
- Always use the clutch while changing gears to avoid damaging the engine, transmission, and drive train, which are not designed to withstand the shock of forced shifting.

# OPERATION AND IMPORTANT RIDING POINTS

## Tips for reducing fuel consumption

EAU16810

Fuel consumption depends largely on your riding style. Consider the following tips to reduce fuel consumption:

- Shift up swiftly, and avoid high engine speeds during acceleration.
- Do not rev the engine while shifting down, and avoid high engine speeds with no load on the engine.
- Turn the engine off instead of letting it idle for an extended length of time (e.g., in traffic jams, at traffic lights or at railroad crossings).

## Engine break-in

EAU16841

There is never a more important period in the life of your engine than the period between 0 and 1600 km (1000 mi). For this reason, you should read the following material carefully.

Since the engine is brand new, do not put an excessive load on it for the first 1600 km (1000 mi). The various parts in the engine wear and polish themselves to the correct operating clearances. During this period, prolonged full-throttle operation or any condition that might result in engine overheating must be avoided.

EAU17030

### 0–1000 km (0–600 mi)

Avoid prolonged operation above 1/3 throttle.

### 1000–1600 km (600–1000 mi)

Avoid prolonged operation above 1/2 throttle.

ECA11440

### CAUTION:

**After 1000 km (600 mi) of operation, the engine oil must be changed, and the oil filter element cleaned.**

### 1600 km (1000 mi) and beyond

The vehicle can now be operated normally.

ECA10270

### CAUTION:

**If any engine trouble should occur during the engine break-in period, immediately have a Yamaha dealer check the vehicle.**

# OPERATION AND IMPORTANT RIDING POINTS

---

EAU17212

## Parking

When parking, stop the engine, and then remove the key from the main switch.

EWA10310

### **WARNING**

- Since the engine and exhaust system can become very hot, park in a place where pedestrians or children are not likely to touch them.
- Do not park on a slope or on soft ground, otherwise the vehicle may overturn.

ECA10380

### **CAUTION:**

Never park in an area where there are fire hazards such as grass or other flammable materials.

# PERIODIC MAINTENANCE AND MINOR REPAIR

EAU17240

Safety is an obligation of the owner. Periodic inspection, adjustment and lubrication will keep your vehicle in the safest and most efficient condition possible. The most important points of inspection, adjustment, and lubrication are explained on the following pages. The intervals given in the periodic maintenance and lubrication chart should be simply considered as a general guide under normal riding conditions. However, DEPENDING ON THE WEATHER, TERRAIN, GEOGRAPHICAL LOCATION, AND INDIVIDUAL USE, THE MAINTENANCE INTERVALS MAY NEED TO BE SHORTENED.

EWA10320



**WARNING**

**If you are not familiar with maintenance work, have a Yamaha dealer do it for you.**

## Owner's tool kit

EAU17520

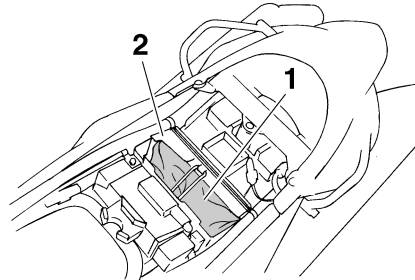

1. Owner's tool kit
2. Engine oil drain attachment

The owner's tool kit is located inside the storage compartment under the seat. (See page 3-12.)

The service information included in this manual and the tools provided in the owner's tool kit are intended to assist you in the performance of preventive maintenance and minor repairs. However, additional tools such as a torque wrench may be necessary to perform certain maintenance work correctly.

**NOTE:** \_\_\_\_\_

If you do not have the tools or experience required for a particular job, have a Yamaha dealer perform it for you.

EWA10350



**WARNING**

**Modifications not approved by Yamaha may cause loss of performance and render the vehicle unsafe for use. Consult a Yamaha dealer before attempting any changes.**

# PERIODIC MAINTENANCE AND MINOR REPAIR

EAU17705

## Periodic maintenance and lubrication chart

### NOTE:

- The annual checks must be performed every year, except if a kilometer-based maintenance is performed instead.
- From 50000 km, repeat the maintenance intervals starting from 10000 km.
- Items marked with an asterisk should be performed by a Yamaha dealer as they require special tools, data and technical skills.

NO.	ITEM	CHECK OR MAINTENANCE JOB	ODOMETER READING (× 1000 km)					ANNUAL CHECK
			1	10	20	30	40	
1	* Fuel line	• Check fuel hoses for cracks or damage.		√	√	√	√	√
2	Spark plug	• Check condition. • Clean and regap.		√		√		
		• Replace.			√		√	
3	* Valves	• Check valve clearance. • Adjust.			√		√	
4	Air filter element	• Replace.			√		√	
5	Clutch	• Check operation. • Adjust.	√	√	√	√	√	
6	* Front brake	• Check operation, fluid level and vehicle for fluid leakage.	√	√	√	√	√	√
		• Replace brake pads.	Whenever worn to the limit					
7	* Rear brake	• Check operation, fluid level and vehicle for fluid leakage.	√	√	√	√	√	√
		• Replace brake pads.	Whenever worn to the limit					
8	* Brake hoses	• Check for cracks or damage.		√	√	√	√	√
		• Replace.	Every 4 years					



# PERIODIC MAINTENANCE AND MINOR REPAIR

NO.	ITEM	CHECK OR MAINTENANCE JOB	ODOMETER READING (× 1000 km)					ANNUAL CHECK
			1	10	20	30	40	
9	* Wheels	<ul style="list-style-type: none"> <li>• Check runout, spoke tightness and for damage.</li> <li>• Tighten spokes if necessary.</li> </ul>	√	√	√	√	√	
10	* Tires	<ul style="list-style-type: none"> <li>• Check tread depth and for damage.</li> <li>• Replace if necessary.</li> <li>• Check air pressure.</li> <li>• Correct if necessary.</li> </ul>		√	√	√	√	√
11	* Wheel bearings	<ul style="list-style-type: none"> <li>• Check bearing for looseness or damage.</li> </ul>		√	√	√	√	
12	* Swingarm	<ul style="list-style-type: none"> <li>• Check operation and for excessive play.</li> </ul>		√	√	√	√	
13	Drive chain	<ul style="list-style-type: none"> <li>• Check chain slack, alignment and condition.</li> <li>• Adjust and lubricate chain with a special O-ring chain lubricant thoroughly.</li> </ul>	Every 500 km and after washing the motorcycle or riding in the rain					
14	* Steering bearings	<ul style="list-style-type: none"> <li>• Check bearing play and steering for roughness.</li> <li>• Lubricate with lithium-soap-based grease.</li> </ul>	√	√	√	√	√	
15	* Chassis fasteners	<ul style="list-style-type: none"> <li>• Make sure that all nuts, bolts and screws are properly tightened.</li> </ul>		√	√	√	√	√
16	Sidestand	<ul style="list-style-type: none"> <li>• Check operation.</li> <li>• Lubricate.</li> </ul>		√	√	√	√	√
17	* Sidestand switch	<ul style="list-style-type: none"> <li>• Check operation.</li> </ul>	√	√	√	√	√	√
18	* Front fork	<ul style="list-style-type: none"> <li>• Check operation and for oil leakage.</li> </ul>		√	√	√	√	
19	* Shock absorber assembly	<ul style="list-style-type: none"> <li>• Check operation and shock absorber for oil leakage.</li> </ul>		√	√	√	√	
20	* Rear suspension relay arm and connecting arm pivoting points	<ul style="list-style-type: none"> <li>• Check operation.</li> </ul>		√	√	√	√	
21	* Fuel injection	<ul style="list-style-type: none"> <li>• Adjust engine idling speed.</li> </ul>	√	√	√	√	√	√
22	Engine oil	<ul style="list-style-type: none"> <li>• Change.</li> <li>• Check oil level and vehicle for oil leakage.</li> </ul>	√	√	√	√	√	√

# PERIODIC MAINTENANCE AND MINOR REPAIR

NO.	ITEM	CHECK OR MAINTENANCE JOB	ODOMETER READING (× 1000 km)					ANNUAL CHECK
			1	10	20	30	40	
23	Engine oil filter element	• Replace.	√		√		√	
24	* Cooling system	• Check coolant level and vehicle for coolant leakage.		√	√	√	√	√
		• Change.	Every 3 years					
25	* Front and rear brake switches	• Check operation.	√	√	√	√	√	√
26	Moving parts and cables	• Lubricate.		√	√	√	√	√
27	* Throttle grip housing and cable	• Check operation and free play. • Adjust the throttle cable free play if necessary. • Lubricate the throttle grip housing and cable.		√	√	√	√	√
28	* Air induction system	• Check the air cut-off valve, reed valve, and hose for damage. • Replace the entire air induction system if necessary.		√	√	√	√	√
29	* Mufflers and exhaust pipes	• Check the screw clamps for looseness.	√	√	√	√	√	√
30	* Lights, signals and switches	• Check operation. • Adjust headlight beam.	√	√	√	√	√	√

EAUM1890

## NOTE:

- Replace the air filter element more frequently if you are riding in unusually wet or dusty areas.
- Hydraulic brake service
  - Regularly check and, if necessary, correct the brake fluid level.
  - Every two years replace the internal components of the brake master cylinder, and change the brake fluid.
  - Replace the brake hoses every four years and if cracked or damaged.

# PERIODIC MAINTENANCE AND MINOR REPAIR

## Removing and installing cowlings and panels

EAU18712

The cowlings and panels shown need to be removed to perform some of the maintenance jobs described in this chapter. Refer to this section each time a cawling or panel needs to be removed and installed.

### XT660R

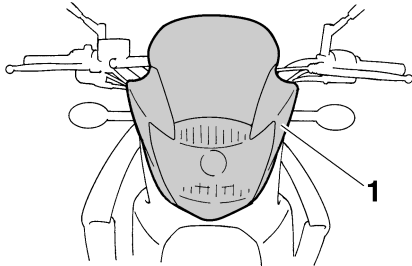

1. Cowling A

### XT660X

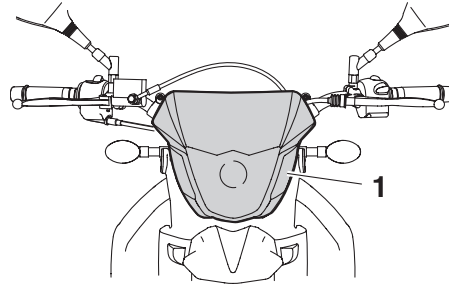

1. Cowling A

### XT660R

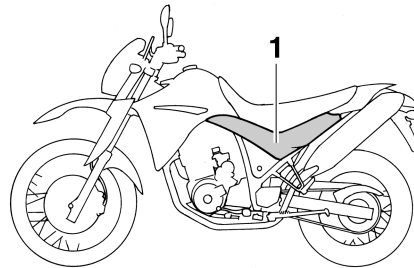

1. Panel A

### XT660X

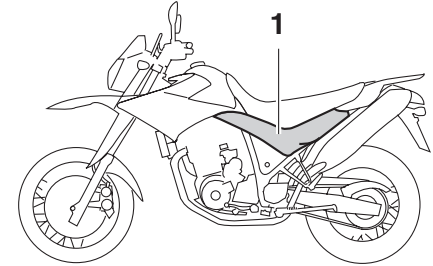

1. Panel A

### XT660R

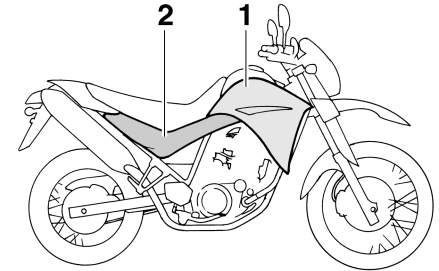

1. Cowling B  
2. Panel B

# PERIODIC MAINTENANCE AND MINOR REPAIR

## XT660X

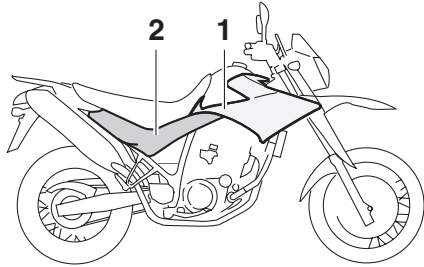

1. Cowling B
2. Panel B

### Cowling A

EAUM1682

#### To remove the cowling

Remove the bolts and spacers, and then lift the cowling up to remove it.

## XT660R

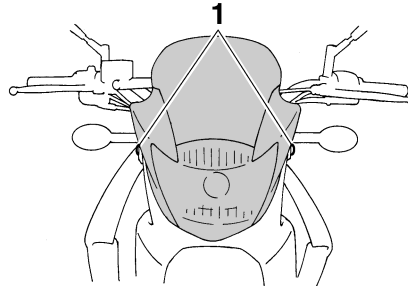

1. Bolt

## XT660X

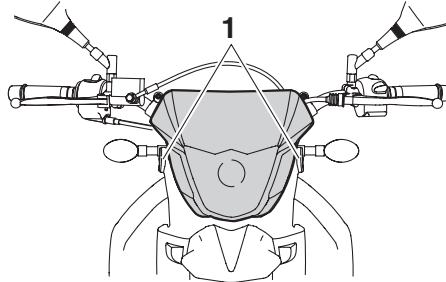

1. Bolt

#### To install the cowling

1. Place the cowling bracket tab between the protector and the bracket on each side.

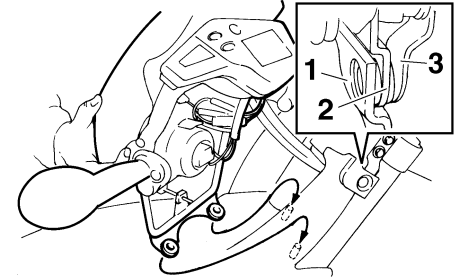

1. Protector
2. Cowling bracket tab
3. Bracket

2. Place the cowling in the original position, and then install the bolts and spacers.

### Cowling B (XT660R)

EAUM1692

#### To remove the cowling

1. Remove the seat and panel B. (See pages 3-12 and 6-5.)
2. Remove the bolts, and then remove the quick fastener screws by turning them 1/4 turn counterclockwise.
3. Pull the cowling off at the area shown.

# PERIODIC MAINTENANCE AND MINOR REPAIR

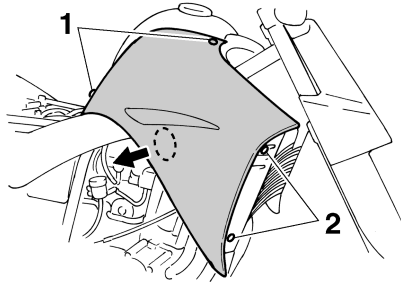

1. Bolt
2. Quick fastener screw

## To install the cowling

1. Place the cowling in the original position, and then install the quick fastener screws and the bolts.

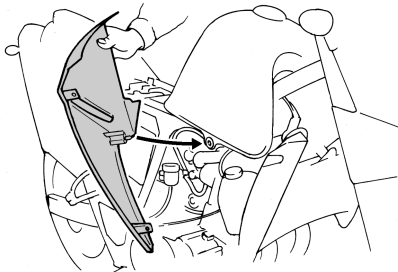

2. Install the panel.
3. Install the seat.

## Cowling B (XT660X)

EAUM2130

### To remove the cowling

1. Remove the seat and panel B. (See pages 3-12 and 6-5.)
2. Remove the bolts, and then remove the quick fastener screw by turning it 1/4 turn counterclockwise.
3. Pull the cowling off at the area shown.

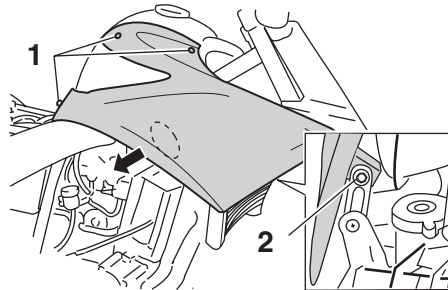

1. Bolt
2. Quick fastener screw

### To install the cowling

1. Place the cowling in the original position, and then install the quick fastener screw and the bolts.

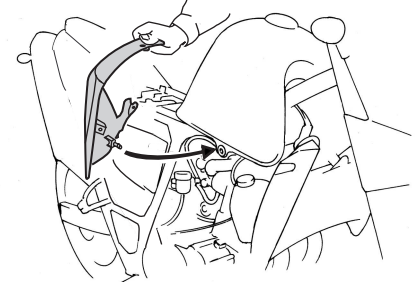

2. Install the panel.
3. Install the seat.

## Panel A

EAUM1701

### To remove the panel

1. Remove the seat. (See page 3-12.)
2. Remove the bolts and the spacer, and then pull the panel off at the area shown.

# PERIODIC MAINTENANCE AND MINOR REPAIR

EAUM1710

## Panel B

### To remove the panel

1. Remove the seat. (See page 3-12.)
2. Remove the bolt, and then pull the panel off at the areas shown.

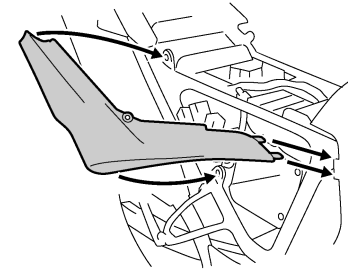

2. Install the seat.

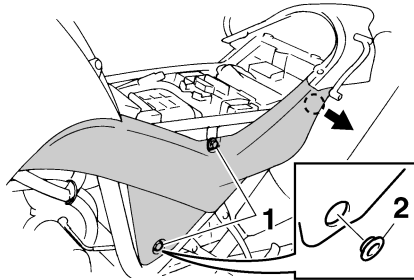

1. Bolt
2. Spacer

### To install the panel

1. Place the panel in the original position, install spacer, and then install the bolts.

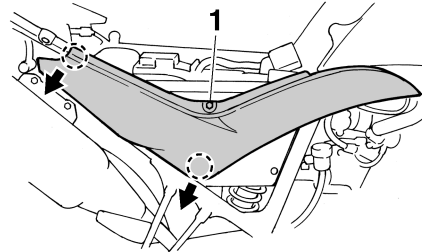

1. Bolt

### To install the panel

1. Place the panel in the original position, and then install the bolt.

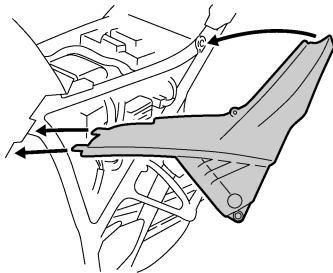

2. Install the seat.

# PERIODIC MAINTENANCE AND MINOR REPAIR

EAU19603

## Checking the spark plug

The spark plug is an important engine component, which is easy to check. Since heat and deposits will cause any spark plug to slowly erode, the spark plug should be removed and checked in accordance with the periodic maintenance and lubrication chart. In addition, the condition of the spark plug can reveal the condition of the engine.

### To remove the spark plug

1. Remove the spark plug cap.

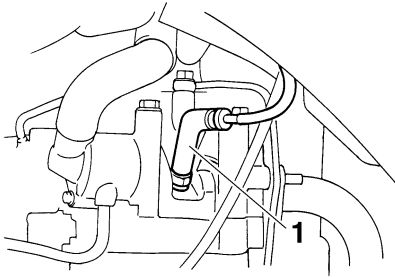

1. Spark plug cap

2. Remove the spark plug as shown, with the spark plug wrench included in the owner's tool kit.

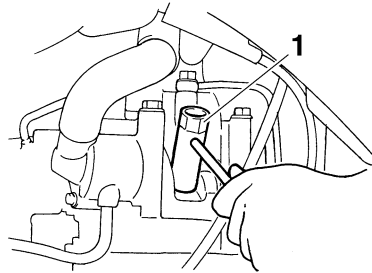

1. Spark plug wrench

### To check the spark plug

1. Check that the porcelain insulator around the center electrode of the spark plug is a medium-to-light tan (the ideal color when the vehicle is ridden normally).

#### NOTE: \_\_\_\_\_

If the spark plug shows a distinctly different color, the engine could be operating improperly. Do not attempt to diagnose such problems yourself. Instead, have a Yamaha dealer check the vehicle.

\_\_\_\_\_

2. Check the spark plug for electrode erosion and excessive carbon or other deposits, and replace it if necessary.

**Specified spark plug:**  
NGK/CR7E

### To install the spark plug

1. Measure the spark plug gap with a wire thickness gauge and, if necessary, adjust the gap to specification.

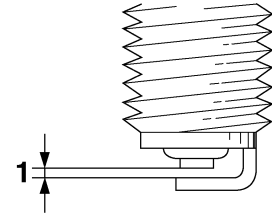

1. Spark plug gap

**Spark plug gap:**  
0.7–0.8 mm (0.028–0.031 in)

# PERIODIC MAINTENANCE AND MINOR REPAIR

2. Clean the surface of the spark plug gasket and its mating surface, and then wipe off any grime from the spark plug threads.
3. Install the spark plug with the spark plug wrench, and then tighten it to the specified torque.

## Tightening torque:

Spark plug:

12.5 Nm (1.25 m·kgf, 9.0 ft·lbf)

## NOTE:

If a torque wrench is not available when installing a spark plug, a good estimate of the correct torque is 1/4–1/2 turn past finger tight. However, the spark plug should be tightened to the specified torque as soon as possible.

4. Install the spark plug cap.

## Engine oil and oil filter element

EAM1841

The engine oil level should be checked before each ride. In addition, the oil must be changed and the oil filter element replaced at the intervals specified in the periodic maintenance and lubrication chart.

## To check the engine oil level

1. Place the vehicle on a level surface and hold it in an upright position.

## NOTE:

Make sure that the vehicle is positioned straight up when checking the oil level. A slight tilt to the side can result in a false reading.

2. Start the engine, warm it up for 10–15 minutes, and then turn it off.
3. Wait a few minutes until the oil settles, remove the oil filler cap, wipe the dipstick clean, insert it back into the oil filler hole (without screwing it in), and then remove it again to check the oil level.

## NOTE:

- The engine oil tank is located inside of the frame.
- The engine oil should be between the minimum and maximum level marks.

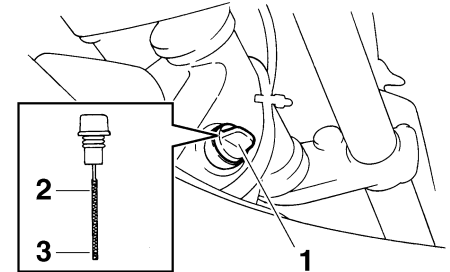

1. Engine oil filler cap
2. Maximum level mark
3. Minimum level mark

## CAUTION:

Do not operate the vehicle until you know that the engine oil level is sufficient.

ECA10010



# PERIODIC MAINTENANCE AND MINOR REPAIR

EWA10360

## WARNING

Never remove the engine oil tank cap after high-speed operation, otherwise hot engine oil could spout out and cause damage or injury. Always let the engine oil cool down sufficiently before removing the oil tank cap.

4. If the engine oil is below the minimum level mark, add sufficient oil of the recommended type to raise it to the correct level.
5. Install the oil filler cap.

### To change the engine oil (with or without oil filter element replacement)

1. Start the engine, warm it up for several minutes, and then turn it off.
2. Install the engine oil drain attachment, provided with the owner's tool kit, under the drain bolt of the crankcase.

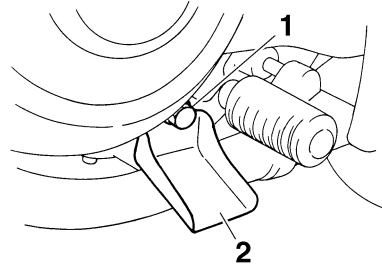

1. Engine oil drain bolt (crankcase)
2. Engine oil drain attachment
3. Place an oil pan under the engine to collect the used oil.
4. Remove the engine oil filler cap and the drain bolt to drain the oil from the crankcase.
5. Remove the drain bolt to drain the oil from the oil tank.

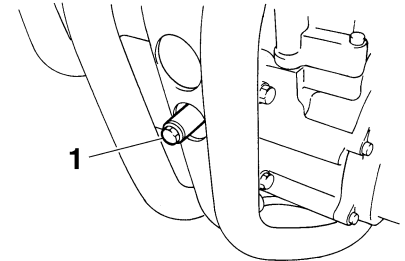

1. Engine oil drain bolt (oil tank)
6. Remove the oil filter element drain bolt to drain the oil from the oil filter element.

### NOTE:

Skip steps 7–9 if the oil filter element is not being replaced.

7. Remove the oil filter element cover by removing the bolts.

# PERIODIC MAINTENANCE AND MINOR REPAIR

ECAM1060

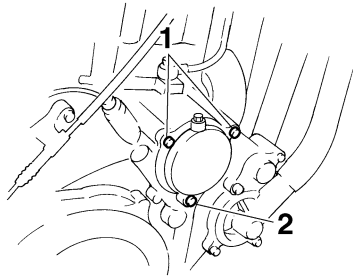

1. Oil filter element cover bolt
2. Oil filter element drain bolt

8. Remove and replace the oil filter element and O-rings.

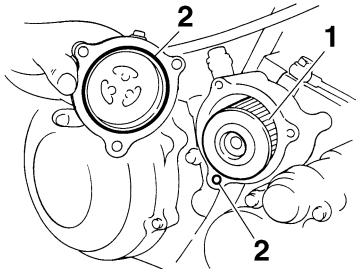

1. Oil filter element
2. O-ring

9. Install the oil filter element cover by installing the bolts and the oil filter element drain bolt, then tightening them to the specified torques.

### Tightening torques:

- Oil filter element cover bolt:  
10 Nm (1.0 m·kgf, 7.2 ft·lbf)
- Oil filter element drain bolt:  
10 Nm (1.0 m·kgf, 7.2 ft·lbf)

**NOTE:** \_\_\_\_\_  
Make sure that the O-rings are properly seated.

10. Install the oil drain bolts, and then tighten them to the specified torques.

### Tightening torques:

- Engine oil drain bolt (crankcase):  
30 Nm (3.0 m·kgf, 22 ft·lbf)
- Engine oil drain bolt (oil tank):  
18 Nm (1.8 m·kgf, 13 ft·lbf)

11. Add the specified amount of the recommended engine oil, and then install and tighten the oil filler cap.

### CAUTION:

The engine oil tank must be filled in 2 steps. First, fill the engine oil tank with 1.90 L (2.0 US qt) (1.67 Imp.qt) of the recommended engine oil. Then, start the engine, race it 5 or 6 times, turn it off, and then add the remainder of the engine oil.

### Recommended engine oil:

See page 8-1.

### Oil quantity:

Without oil filter element replacement:

2.50 L (2.64 US qt) (2.20 Imp.qt)

With oil filter element replacement:

2.60 L (2.75 US qt) (2.29 Imp.qt)

ECA11620

### CAUTION:

- In order to prevent clutch slippage (since the engine oil also lubricates the clutch), do not mix any chemical additives. Do not use oils with a diesel specification of “CD” or oils of a higher quality than specified. In

# PERIODIC MAINTENANCE AND MINOR REPAIR

addition, do not use oils labeled “ENERGY CONSERVING II” or higher.

- **Make sure that no foreign material enters the crankcase.**

12. Start the engine, and then let it idle for several minutes while checking it for oil leakage. If oil is leaking, immediately turn the engine off and check for the cause.
13. Turn the engine off, and then check the oil level and correct it if necessary.

## Coolant

The coolant level should be checked before each ride. In addition, the coolant must be changed at the intervals specified in the periodic maintenance and lubrication chart.

### To check the coolant level

1. Place the vehicle on a level surface and hold it in an upright position.

**NOTE:** \_\_\_\_\_

- The coolant level must be checked on a cold engine since the level varies with engine temperature.
- Make sure that the vehicle is positioned straight up when checking the coolant level. A slight tilt to the side can result in a false reading.

2. Check the coolant level in the coolant reservoir.

**NOTE:** \_\_\_\_\_

The coolant should be between the minimum and maximum level marks.

EAU20070

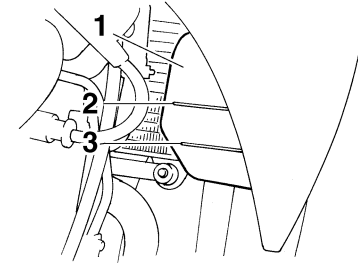

EAUM1722

1. Coolant reservoir
2. Maximum level mark
3. Minimum level mark

3. If the coolant is at or below the minimum level mark, remove cowl-  
ing B (See page 6-5.), and then  
open the reservoir cap.
4. Add coolant to the maximum level  
mark, and then close the reservoir  
cap.

**Coolant reservoir capacity (up to the maximum level mark):**

0.25 L (0.26 US qt) (0.22 Imp.qt)

# PERIODIC MAINTENANCE AND MINOR REPAIR

ECA10471

## CAUTION:

- If coolant is not available, use distilled water or soft tap water instead. Do not use hard water or salt water since it is harmful to the engine.
- If water has been used instead of coolant, replace it with coolant as soon as possible, otherwise the cooling system will not be protected against frost and corrosion.
- If water has been added to the coolant, have a Yamaha dealer check the antifreeze content of the coolant as soon as possible, otherwise the effectiveness of the coolant will be reduced.

EWA10380

## WARNING

Never attempt to remove the radiator cap when the engine is hot.

5. Install the cowling.

## NOTE:

- The radiator fan is automatically switched on or off according to the coolant temperature in the radiator.
- If the engine overheats, see page 6-40 for further instructions.

EAUM1802

## To change the coolant

1. Place the vehicle on a level surface and let the engine cool if necessary.
2. Remove the seat and panel B. (See pages 3-12 and 6-5.)
3. Remove cowling B. (See page 6-5.)
4. Place a container under the engine to collect the used coolant.
5. Loosen the radiator cap retainer screw.
6. Remove the radiator cap and coolant reservoir cap.

EWA10380

## WARNING

Never attempt to remove the radiator cap when the engine is hot.

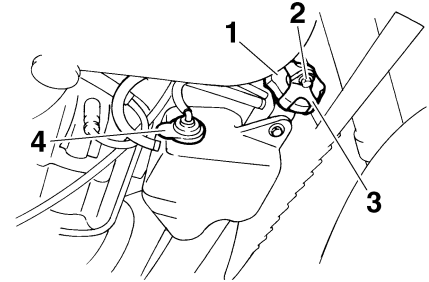

1. Radiator cap
2. Radiator cap retaining screw
3. Radiator cap retainer
4. Coolant reservoir cap
7. Remove the coolant reservoir bolts, and then turn the coolant reservoir upside down to empty it.
8. Install the coolant reservoir by placing it in the original position, then installing the bolts.

# PERIODIC MAINTENANCE AND MINOR REPAIR

ECA10471

## CAUTION:

- If coolant is not available, use distilled water or soft tap water instead. Do not use hard water or salt water since it is harmful to the engine.
- If water has been used instead of coolant, replace it with coolant as soon as possible, otherwise the cooling system will not be protected against frost and corrosion.
- If water has been added to the coolant, have a Yamaha dealer check the antifreeze content of the coolant as soon as possible, otherwise the effectiveness of the coolant will be reduced.

13. Install the coolant reservoir cap.
14. Install the radiator cap and radiator cap retainer by installing the screw.
15. Start the engine, let it idle for several minutes, and then turn it off.

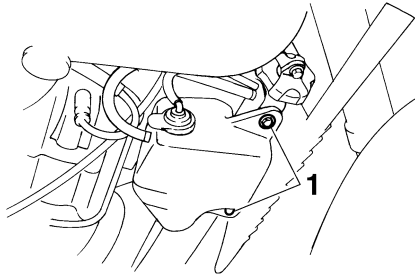

1. Bolt

9. Remove the coolant drain bolt to drain the cooling system.

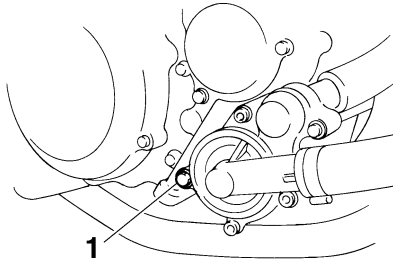

1. Coolant drain bolt

10. After the coolant is completely drained, thoroughly flush the cooling system with clean tap water.

11. Install the coolant drain bolt, and then tighten it to the specified torque.

## NOTE:

Check the washer for damage and replace it if necessary.

### Tightening torque:

Coolant drain bolt:  
11 Nm (1.1 m·kgf, 8.0 ft·lbf)

12. Pour the specified amount of the recommended coolant into the radiator and reservoir.

### Antifreeze/water mixture ratio:

1:1

### Recommended antifreeze:

High-quality ethylene glycol antifreeze containing corrosion inhibitors for aluminum engines

### Coolant quantity:

Radiator capacity (including all routes):

1.00 L (1.06 US qt) (0.88 Imp.qt)

Coolant reservoir capacity (up to the maximum level mark):

0.25 L (0.26 US qt) (0.22 Imp.qt)

# PERIODIC MAINTENANCE AND MINOR REPAIR

16. Check the coolant level in the reservoir. If necessary, remove the coolant reservoir cap, add coolant to the maximum level mark, and then install the cap.
17. Start the engine, and then check the vehicle for coolant leakage. If coolant is leaking, have a Yamaha dealer check the cooling system.
18. Install the cowling, the panel and the seat.

## Replacing the air filter element and cleaning the check hose

EAUM1833

The air filter element should be replaced at the intervals specified in the periodic maintenance and lubrication chart. Replace the air filter element more frequently if you are riding in unusually wet or dusty areas. In addition, the air filter check hose must be frequently checked and cleaned if necessary.

### To replace the air filter element

1. Remove the seat. (See page 3-12.)
2. Remove panel B. (See page 6-5.)
3. Remove the air filter case cover by removing the screws.

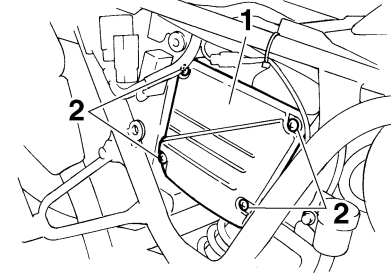

1. Air filter case cover
2. Screw

4. Pull the air filter element out.
5. Insert a new air filter element into the air filter case as shown.

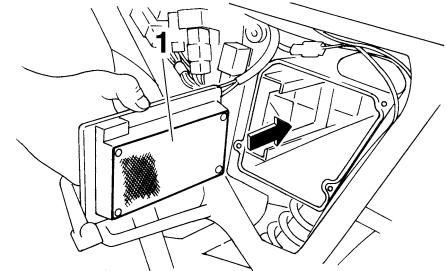

1. Air filter element

# PERIODIC MAINTENANCE AND MINOR REPAIR

ECA10480

## CAUTION:

- Make sure that the air filter element is properly seated in the air filter case.
- The engine should never be operated without the air filter element installed, otherwise the piston(s) and/or cylinder(s) may become excessively worn.

6. Install the air filter case cover by installing the screws.
7. Install the panel.
8. Install the seat.

## To clean the air filter check hose

1. Check the hose on the side of the air filter case for accumulated dirt or water.

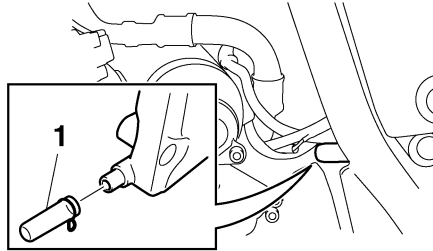

1. Air filter check hose

2. If dirt or water is visible, remove the hose, clean it, and then install it.

## Adjusting the engine idling speed

The engine idling speed must be checked and, if necessary, adjusted as follows at the intervals specified in the periodic maintenance and lubrication chart.

The engine should be warm before making this adjustment.

## NOTE:

- The engine is warm when it quickly responds to the throttle.
- A diagnostic tachometer is needed to make this adjustment.

1. Attach the tachometer to the spark plug lead.
2. Check the engine idling speed and, if necessary, adjust it to specification by turning the idle adjusting screw. To increase the engine idling speed, turn the screw in direction (a). To decrease the engine idling speed, turn the screw in direction (b).

# PERIODIC MAINTENANCE AND MINOR REPAIR

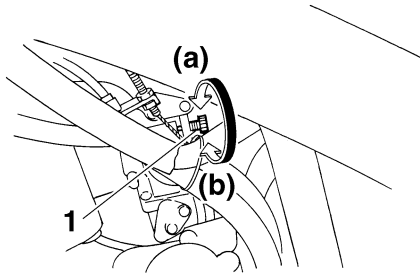

1. Idle adjusting screw

**Engine idling speed:**  
1400–1500 r/min

6

**NOTE:** \_\_\_\_\_  
If the specified idling speed cannot be obtained as described above, have a Yamaha dealer make the adjustment.  
\_\_\_\_\_

## Checking the throttle cable free play

EAU21381

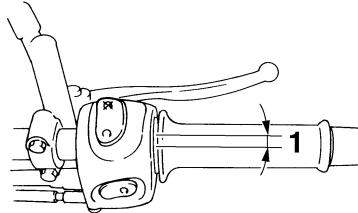

1. Throttle cable free play

The throttle cable free play should measure 3.0–5.0 mm (0.12–0.20 in) at the throttle grip. Periodically check the throttle cable free play and, if necessary, have a Yamaha dealer adjust it.

EAU21640

## Tires

To maximize the performance, durability, and safe operation of your motorcycle, note the following points regarding the specified tires.

### Tire air pressure

The tire air pressure should be checked and, if necessary, adjusted before each ride.

EWA10500

### **⚠ WARNING**

- The tire air pressure must be checked and adjusted on cold tires (i.e., when the temperature of the tires equals the ambient temperature).
- The tire air pressure must be adjusted in accordance with the riding speed and with the total weight of rider, passenger, cargo, and accessories approved for this model.



# PERIODIC MAINTENANCE AND MINOR REPAIR

EWA11020

- Check the tire condition and air pressure before each ride.

**Tire air pressure (measured on cold tires):**

**0–90 kg (0–198 lb):**

Front:

XT660R 200 kPa (29 psi) (2.00 kgf/cm<sup>2</sup>)

XT660X 210 kPa (30 psi) (2.10 kgf/cm<sup>2</sup>)

Rear:

XT660R 200 kPa (29 psi) (2.00 kgf/cm<sup>2</sup>)

XT660X 210 kPa (30 psi) (2.10 kgf/cm<sup>2</sup>)

**90–186 kg (198–410 lb):**

Front:

XT660R 200 kPa (29 psi) (2.00 kgf/cm<sup>2</sup>)

XT660X 220 kPa (32 psi) (2.20 kgf/cm<sup>2</sup>)

Rear:

XT660R 225 kPa (33 psi) (2.25 kgf/cm<sup>2</sup>)

XT660X 230 kPa (33 psi) (2.30 kgf/cm<sup>2</sup>)

**Off-road riding:**

Front:

XT660R 200 kPa (29 psi) (2.00 kgf/cm<sup>2</sup>)

Rear:

XT660R 200 kPa (29 psi) (2.00 kgf/cm<sup>2</sup>)

**Maximum load\*:**

186 kg (410 lb)

\* Total weight of rider, passenger, cargo and accessories

## **WARNING**

Because loading has an enormous impact on the handling, braking, performance and safety characteristics of your motorcycle, you should keep the following precautions in mind.

- **NEVER OVERLOAD THE MOTORCYCLE!** Operation of an overloaded motorcycle may result in tire damage, loss of control, or severe injury. Make sure that the total weight of rider, passenger, cargo, and accessories does not exceed the specified maximum load for the vehicle.
- Do not carry along loosely packed items, which can shift during a ride.
- Securely pack the heaviest items close to the center of the motorcycle and distribute the weight evenly on both sides.
- Adjust the suspension and tire air pressure with regard to the load.

## Tire inspection

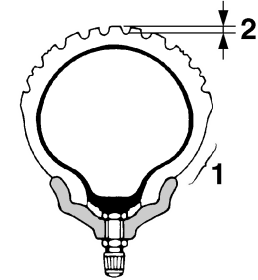

1. Tire sidewall
2. Tire tread depth

The tires must be checked before each ride. If the center tread depth reaches the specified limit, if the tire has a nail or glass fragments in it, or if the sidewall is cracked, have a Yamaha dealer replace the tire immediately.

**Minimum tire tread depth (front and rear):**  
1.6 mm (0.06 in)

# PERIODIC MAINTENANCE AND MINOR REPAIR

EWA10570

## NOTE: \_\_\_\_\_

The tire tread depth limits may differ from country to country. Always comply with the local regulations.

## Tire information

This motorcycle is equipped with tube tires.

EWA10460

### **WARNING**

- The front and rear tires should be of the same make and design, otherwise the handling characteristics of the vehicle cannot be guaranteed.
- After extensive tests, only the tires listed below have been approved for this model by Yamaha Motor Co., Ltd.

### Front tire:

#### Size:

XT660R 90/90-21M/C 54S,  
90/90-21M/C 54T  
XT660X 120/70R17 M/C 58H,  
120/70ZR17 M/C 58W,  
120/70ZR17 M/C 58W

#### Manufacturer/model:

XT660R METZELER/TOURANCE  
FRONT,  
MICHELIN/SIRAC  
XT660X PIRELLI/Dragon,  
METZELER/SPORTEC M1,  
MICHELIN/RADIAL PILOT  
SPORT

### Rear tire:

#### Size:

XT660R 130/80-17M/C 65S,  
130/80-17M/C 65T  
XT660X 160/60R17 M/C 69H,  
160/60ZR17 M/C 69W,  
160/60ZR17 M/C 69W

#### Manufacturer/model:

XT660R METZELER/TOU-  
RANCE,  
MICHELIN/SIRAC  
XT660X PIRELLI/Dragon,  
METZELER/SPORTEC M1,  
MICHELIN/RADIAL PILOT  
SPORT

### **WARNING**

- Have a Yamaha dealer replace excessively worn tires. Besides being illegal, operating the motorcycle with excessively worn tires decreases riding stability and can lead to loss of control.
- The replacement of all wheel- and brake-related parts, including the tires, should be left to a Yamaha dealer, who has the necessary professional knowledge and experience.
- It is not recommended to patch a punctured tube. If unavoidable, however, patch the tube very carefully and replace it as soon as possible with a high-quality product.

# PERIODIC MAINTENANCE AND MINOR REPAIR

## Spoke wheels

EAU21940

To maximize the performance, durability, and safe operation of your motorcycle, note the following points regarding the specified wheels.

- The wheel rims should be checked for cracks, bends or warpage, and the spokes for looseness or damage before each ride. If any damage is found, have a Yamaha dealer replace the wheel. Do not attempt even the smallest repair to the wheel. A deformed or cracked wheel must be replaced.
- The wheel should be balanced whenever either the tire or wheel has been changed or replaced. An unbalanced wheel can result in poor performance, adverse handling characteristics, and a shortened tire life.
- Ride at moderate speeds after changing a tire since the tire surface must first be “broken in” for it to develop its optimal characteristics.

## Adjusting the clutch lever free play

EAU22041

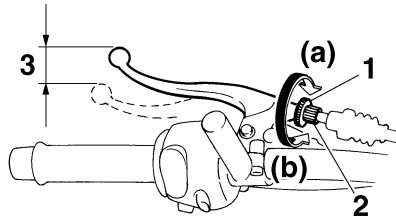

1. Locknut
2. Clutch lever free play adjusting bolt
3. Clutch lever free play

The clutch lever free play should measure 10.0–15.0 mm (0.39–0.59 in) as shown. Periodically check the clutch lever free play and, if necessary, adjust it as follows.

1. Loosen the locknut at the clutch lever.
2. To increase the clutch lever free play, turn the adjusting bolt in direction (a). To decrease the clutch lever free play, turn the adjusting bolt in direction (b).

## NOTE: \_\_\_\_\_

If the specified clutch lever free play could be obtained as described above, tighten the locknut and skip the rest of the procedure, otherwise proceed as follows.

3. Fully turn the adjusting bolt at the clutch lever in direction (a) to loosen the clutch cable.
4. Loosen the locknut at the crankcase.

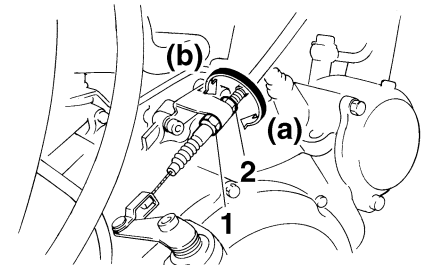

1. Locknut
2. Clutch lever free play adjusting nut (crankcase)

# PERIODIC MAINTENANCE AND MINOR REPAIR

5. To increase the clutch lever free play, turn the adjusting nut in direction (a). To decrease the clutch lever free play, turn the adjusting nut in direction (b).
6. Tighten the locknut at the clutch lever and the crankcase.

## Adjusting the rear brake light switch

EAU22270

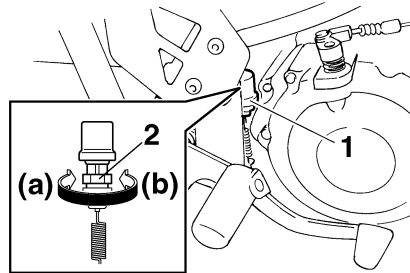

1. Rear brake light switch
2. Rear brake light switch adjusting nut

The rear brake light switch, which is activated by the brake pedal, is properly adjusted when the brake light comes on just before braking takes effect. If necessary, adjust the brake light switch as follows.

Turn the adjusting nut while holding the rear brake light switch in place. To make the brake light come on earlier, turn the adjusting nut in direction (a). To make the brake light come on later, turn the adjusting nut in direction (b).

## Checking the front and rear brake pads

EAU22390

The front and rear brake pads must be checked for wear at the intervals specified in the periodic maintenance and lubrication chart.

### Front brake pads

EAU22430

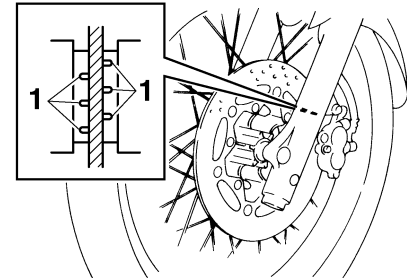

1. Brake pad wear indicator groove

Each front brake pad is provided with wear indicator grooves, which allow you to check the brake pad wear without having to disassemble the brake. To check the brake pad wear, check the wear indicator grooves. If a brake pad has worn to the point that the wear

# PERIODIC MAINTENANCE AND MINOR REPAIR

indicator grooves have almost disappeared, have a Yamaha dealer replace the brake pads as a set.

## Rear brake pads

EAU22500

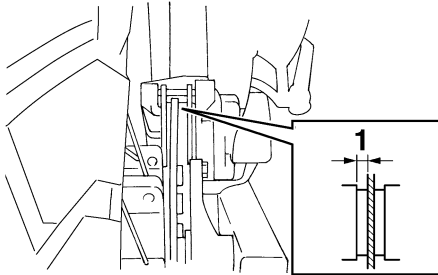

1. Lining thickness

Check each rear brake pad for damage and measure the lining thickness. If a brake pad is damaged or if the lining thickness is less than 1.0 mm (0.04 in), have a Yamaha dealer replace the brake pads as a set.

## Checking the brake fluid level

EAU22580

### Front brake

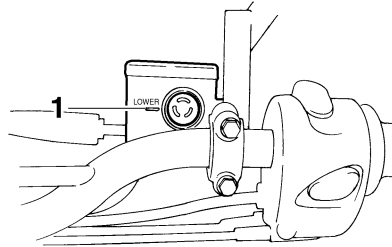

1. Minimum level mark

### Rear brake

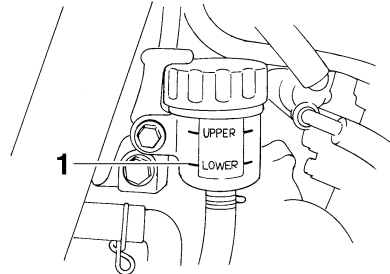

1. Minimum level mark

Insufficient brake fluid may allow air to enter the brake system, possibly causing it to become ineffective.

Before riding, check that the brake fluid is above the minimum level mark and replenish if necessary. A low brake fluid level may indicate worn brake pads and/or brake system leakage. If the brake fluid level is low, be sure to check the brake pads for wear and the brake system for leakage.

Observe these precautions:

- When checking the fluid level, make sure that the top of the brake fluid reservoir is level.
- Use only the recommended quality brake fluid, otherwise the rubber seals may deteriorate, causing leakage and poor braking performance.

**Recommended brake fluid:**  
DOT 4

- Refill with the same type of brake fluid. Mixing fluids may result in a harmful chemical reaction and lead to poor braking performance.

# PERIODIC MAINTENANCE AND MINOR REPAIR

- Be careful that water does not enter the brake fluid reservoir when refilling. Water will significantly lower the boiling point of the fluid and may result in vapor lock.
- Brake fluid may deteriorate painted surfaces or plastic parts. Always clean up spilled fluid immediately.
- As the brake pads wear, it is normal for the brake fluid level to gradually go down. However, if the brake fluid level goes down suddenly, have a Yamaha dealer check the cause.

## Drive chain slack

EAU22760

The drive chain slack should be checked before each ride and adjusted if necessary.

## To check the drive chain slack

EAU22782

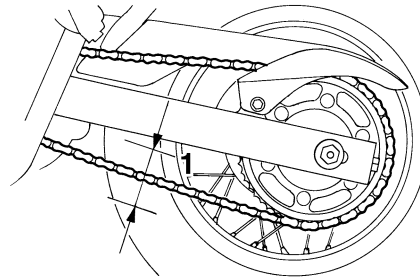

1. Drive chain slack

1. Place the motorcycle on the side-stand.

**NOTE:** \_\_\_\_\_

When checking and adjusting the drive chain slack, there should be no weight on the motorcycle.

2. Shift the transmission into the neutral position.

3. Move the rear wheel by pushing the motorcycle to locate the tightest portion of the drive chain, and then measure the drive chain slack as shown.

### Drive chain slack:

40.0–55.0 mm (1.57–2.17 in)

4. If the drive chain slack is incorrect, adjust it as follows.

**NOTE:** \_\_\_\_\_

When checking the drive chain slack, the chain tensioner should not be touching the drive chain.

## To adjust the drive chain slack (XT660R)

EAU22932

1. Loosen the axle nut, then loosen the locknut at each end of the swingarm.
2. To tighten the drive chain, turn the adjusting nut at each end of the swingarm in direction (a). To loosen the drive chain, turn the adjusting nut at each end of the swingarm in direction (b), and then push the rear wheel forward.

# PERIODIC MAINTENANCE AND MINOR REPAIR

## NOTE:

Using the alignment marks on each side of the swingarm, make sure that both adjusting nuts are in the same position for proper wheel alignment.

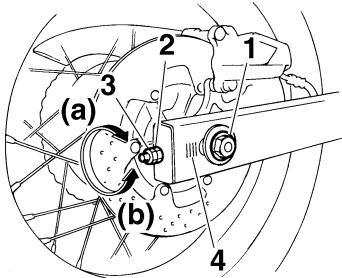

1. Axle nut
2. Drive chain slack adjusting nut
3. Locknut
4. Alignment marks

ECA10570

## CAUTION:

**Improper drive chain slack will overload the engine as well as other vital parts of the motorcycle and can lead to chain slippage or breakage. To prevent this from occurring, keep the drive chain slack within the specified limits.**

3. Tighten the locknuts, and then tighten the axle nut to the specified torque.

### Tightening torque:

Locknut:

16 Nm (1.6 m-kgf, 11 ft-lbf)

Axle nut:

104 Nm (10.4 m-kgf, 75 ft-lbf)

EAU34311

## To adjust the drive chain slack (XT660X)

1. Loosen the axle nut and the locknut on each side of the swingarm.
2. To tighten the drive chain, turn the adjusting bolt on each side of the swingarm in direction (a). To loosen the drive chain, turn the adjusting bolt on each side of the swingarm in direction (b), and then push the rear wheel forward.

## NOTE:

Using the alignment marks on each side of the swingarm, make sure that both chain pullers are in the same position for proper wheel alignment.

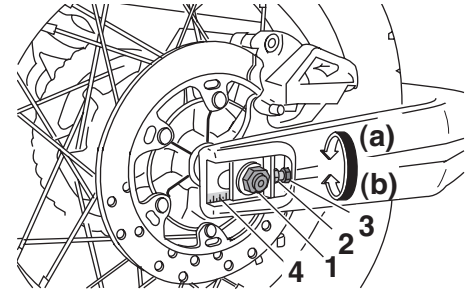

1. Axle nut
2. Drive chain slack adjusting bolt
3. Locknut
4. Alignment marks

ECA10570

## CAUTION:

**Improper drive chain slack will overload the engine as well as other vital parts of the motorcycle and can lead to chain slippage or breakage. To prevent this from occurring, keep the drive chain slack within the specified limits.**

3. Tighten the locknuts, then the axle nut to their specified torques.

# PERIODIC MAINTENANCE AND MINOR REPAIR

## Tightening torques:

Locknut:

16 Nm (1.6 m·kgf, 11 ft·lbf)

Axle nut:

104 Nm (10.4 m·kgf, 75 ft·lbf)

EAU23022

ECA11110

## Cleaning and lubricating the drive chain

The drive chain must be cleaned and lubricated at the intervals specified in the periodic maintenance and lubrication chart, otherwise it will quickly wear out, especially when riding in dusty or wet areas. Service the drive chain as follows.

ECA10581

### CAUTION:

**The drive chain must be lubricated after washing the motorcycle and riding in the rain.**

1. Clean the drive chain with kerosene and a small soft brush.

ECA11120

### CAUTION:

**To prevent damaging the O-rings, do not clean the drive chain with steam cleaners, high-pressure washers or inappropriate solvents.**

2. Wipe the drive chain dry.
3. Thoroughly lubricate the drive chain with a special O-ring chain lubricant.

### CAUTION:

**Do not use engine oil or any other lubricants for the drive chain, as they may contain substances that could damage the O-rings.**



# PERIODIC MAINTENANCE AND MINOR REPAIR

## Checking and lubricating the cables

EAU23100

The operation of all control cables and the condition of the cables should be checked before each ride, and the cables and cable ends should be lubricated if necessary. If a cable is damaged or does not move smoothly, have a Yamaha dealer check or replace it.

**Recommended lubricant:**  
Engine oil

EWA10720

### **WARNING**

Damage to the outer sheath may interfere with proper cable operation and will cause the inner cable to rust. Replace a damaged cable as soon as possible to prevent unsafe conditions.

## Checking and lubricating the throttle grip and cable

EAU23111

The operation of the throttle grip should be checked before each ride. In addition, the cable should be lubricated at the intervals specified in the periodic maintenance chart.

## Checking and lubricating the brake and clutch levers

EAU23140

### Brake lever

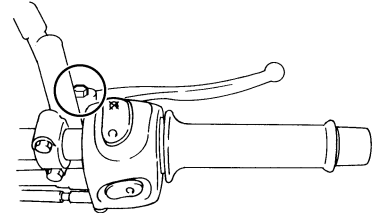

### Clutch lever

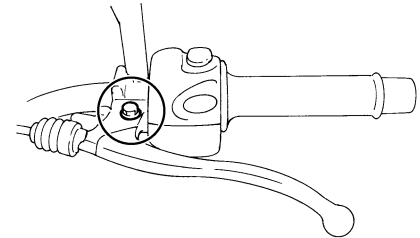

The operation of the brake and clutch levers should be checked before each ride, and the lever pivots should be lubricated if necessary.

# PERIODIC MAINTENANCE AND MINOR REPAIR

## Recommended lubricant:

Lithium-soap-based grease (all-purpose grease)

## Lubricating the brake pedal

EAU23180

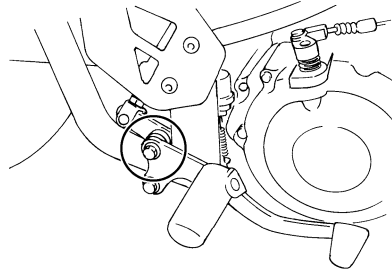

The operation of the brake pedal should be checked before each ride, and the pedal pivot should be lubricated if necessary.

## Recommended lubricant:

Lithium-soap-based grease (all-purpose grease)

## Checking and lubricating the sidestand

EAU23200

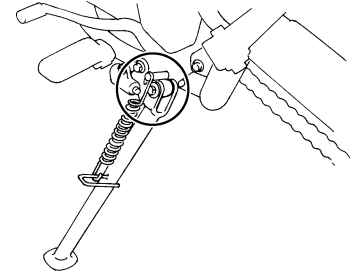

The operation of the sidestand should be checked before each ride, and the sidestand pivot and metal-to-metal contact surfaces should be lubricated if necessary.

EWA10730

## **⚠ WARNING**

**If the sidestand does not move up and down smoothly, have a Yamaha dealer check or repair it.**

## Recommended lubricant:

Lithium-soap-based grease (all-purpose grease)

EAU23271

## Checking the front fork

The condition and operation of the front fork must be checked as follows at the intervals specified in the periodic maintenance and lubrication chart.

### To check the condition

EWA10750



**WARNING**

**Securely support the vehicle so that there is no danger of it falling over.**

Check the inner tubes for scratches, damage and excessive oil leakage.

### To check the operation

1. Place the vehicle on a level surface and hold it in an upright position.
2. While applying the front brake, push down hard on the handlebars several times to check if the front fork compresses and rebounds smoothly.

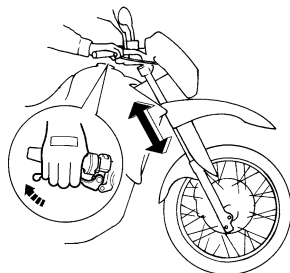

ECA10590

### CAUTION:

**If any damage is found or the front fork does not operate smoothly, have a Yamaha dealer check or repair it.**

EAU23280

## Checking the steering

Worn or loose steering bearings may cause danger. Therefore, the operation of the steering must be checked as follows at the intervals specified in the periodic maintenance and lubrication chart.

1. Place a stand under the engine to raise the front wheel off the ground.

EWA10750



**WARNING**

**Securely support the vehicle so that there is no danger of it falling over.**

2. Hold the lower ends of the front fork legs and try to move them forward and backward. If any free play can be felt, have a Yamaha dealer check or repair the steering.

# PERIODIC MAINTENANCE AND MINOR REPAIR

---

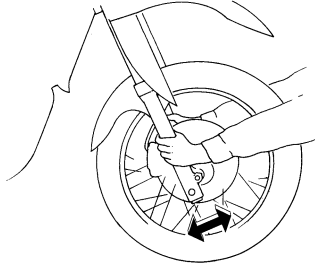

EAU23290

## Checking the wheel bearings

The front and rear wheel bearings must be checked at the intervals specified in the periodic maintenance and lubrication chart. If there is play in the wheel hub or if the wheel does not turn smoothly, have a Yamaha dealer check the wheel bearings.

EAUM1730

## Battery

This model is equipped with a sealed-type (MF) battery, which does not require any maintenance. There is no need to check the electrolyte or to add distilled water.

ECA10620

### **CAUTION:**

**Never attempt to remove the battery cell seals, as this would permanently damage the battery.**

---

### To access the battery

1. Remove the seat. (See page 3-12.)
2. Remove the battery cover by removing the bolts.

# PERIODIC MAINTENANCE AND MINOR REPAIR

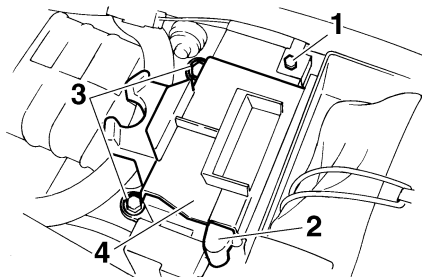

1. Negative battery terminal
2. Positive battery terminal
3. Bolt
4. Battery cover

## To charge the battery

Have a Yamaha dealer charge the battery as soon as possible if it seems to have discharged. Keep in mind that the battery tends to discharge more quickly if the vehicle is equipped with optional electrical accessories.

EWA10760

### **WARNING**

- **Electrolyte is poisonous and dangerous since it contains sulfuric acid, which causes severe burns. Avoid any contact with skin, eyes or clothing and always shield your eyes when**

**working near batteries. In case of contact, administer the following FIRST AID.**

- **EXTERNAL:** Flush with plenty of water.
  - **INTERNAL:** Drink large quantities of water or milk and immediately call a physician.
  - **EYES:** Flush with water for 15 minutes and seek prompt medical attention.
- **Batteries produce explosive hydrogen gas. Therefore, keep sparks, flames, cigarettes, etc., away from the battery and provide sufficient ventilation when charging it in an enclosed space.**
  - **KEEP THIS AND ALL BATTERIES OUT OF THE REACH OF CHILDREN.**

## To store the battery

1. If the vehicle will not be used for more than one month, remove the battery, fully charge it, and then place it in a cool, dry place.

2. If the battery will be stored for more than two months, check it at least once a month and fully charge it if necessary.
3. Fully charge the battery before installation.
4. After installation, make sure that the battery leads are properly connected to the battery terminals.

ECA10630

### **CAUTION:**

- **Always keep the battery charged. Storing a discharged battery can cause permanent battery damage.**
- **To charge a sealed-type (MF) battery, a special (constant-voltage) battery charger is required. Using a conventional battery charger will damage the battery. If you do not have access to a sealed-type (MF) battery charger, have a Yamaha dealer charge your battery.**

# PERIODIC MAINTENANCE AND MINOR REPAIR

EAUM1740

## Replacing the fuses

The main fuse is located behind panel A. (See page 6-5.)

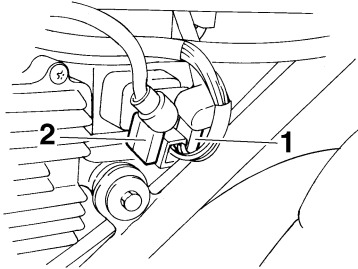

1. Main fuse
2. Spare main fuse

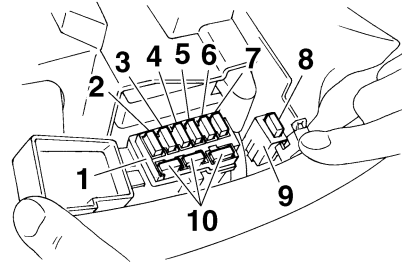

1. Fuse box 1
2. Signaling system fuse
3. Headlight fuse
4. Ignition fuse
5. Fuel injection system fuse
6. Radiator fan fuse
7. Backup fuse (for odometer, clock and immobilizer system)
8. Parking lighting fuse
9. Fuse box 2
10. Spare fuse

If a fuse is blown, replace it as follows.

1. Turn the key to "OFF" and turn off the electrical circuit in question.
2. Remove the blown fuse, and then install a new fuse of the specified amperage.

### Specified fuses:

Main fuse:  
30.0 A

#### Fuse box 1:

Headlight fuse:  
20.0 A

Signaling system fuse:  
10.0 A

Radiator fan fuse:  
7.5 A

Ignition fuse:  
10.0 A

Fuel injection system fuse:  
10.0 A

Backup fuse:  
10.0 A

#### Fuse box 2:

Parking lighting fuse:  
10.0 A

ECA10640

### CAUTION:

**Do not use a fuse of a higher amperage rating than recommended to avoid causing extensive damage to the electrical system and possibly a fire.**

3. Turn the key to "ON" and turn on the electrical circuit in question to check if the device operates.

Fuse box 1 and fuse box 2 are located under the seat. (See page 3-12.)

# PERIODIC MAINTENANCE AND MINOR REPAIR

4. If the fuse immediately blows again, have a Yamaha dealer check the electrical system.

## Replacing the headlight bulb EAUM1750

This model is equipped with a quartz bulb headlight. If the headlight bulb burns out, replace it as follows.

1. Remove cowling A together with the headlight unit. (See page 6-5.)
2. Disconnect the headlight coupler, and then remove the headlight bulb cover.

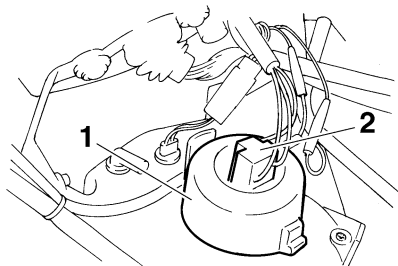

1. Headlight bulb cover
2. Headlight coupler

3. Remove the headlight bulb holder by turning it counterclockwise, and then remove the defective bulb.

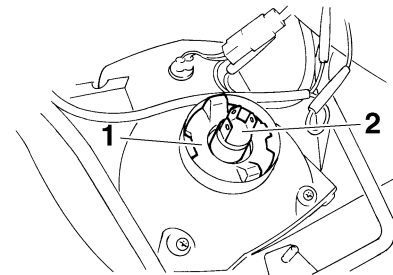

1. Headlight bulb holder
2. Headlight bulb

### **WARNING**

Headlight bulbs get very hot. Therefore, keep flammable products away from a lit headlight bulb, and do not touch the bulb until it has cooled down.

4. Place a new bulb into position, and then secure it with the bulb holder.

### **CAUTION:**

Do not touch the glass part of the headlight bulb to keep it free from oil, otherwise the transparency of the glass, the luminosity of the bulb, and the bulb life will be adversely af-

# PERIODIC MAINTENANCE AND MINOR REPAIR

ected. Thoroughly clean off any dirt and fingerprints on the headlight bulb using a cloth moistened with alcohol or thinner.

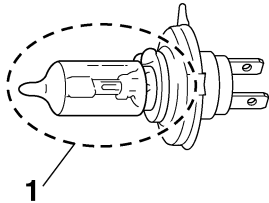

1. Do not touch the glass part of the bulb.

5. Install the bulb cover, and then connect the coupler.
6. Install the cowling together with the headlight unit.
7. Have a Yamaha dealer adjust the headlight beam if necessary.

## Replacing a turn signal light bulb or the tail/brake light bulb

EAU24281

1. Remove the lens by removing the screws.

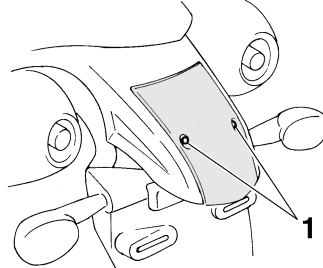

1. Screw

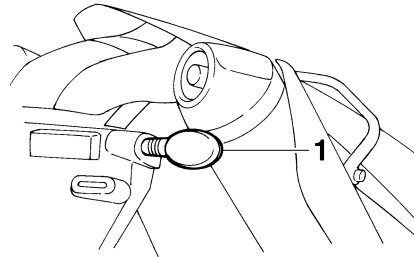

1. Screw

2. Remove the defective bulb by pushing it in and turning it counter-clockwise.
3. Insert a new bulb into the socket, push it in, and then turn it clockwise until it stops.
4. Install the lens by installing the screws.

ECA10680

### CAUTION:

**Do not overtighten the screws, otherwise the lens may break.**



## Replacing an auxiliary light bulb

EAUM1820

If the auxiliary light bulb burns out, replace it as follows.

1. Remove cowling A together with the headlight unit. (See page 6-5.)
2. Remove the auxiliary light socket (together with the bulb) by pulling it out.

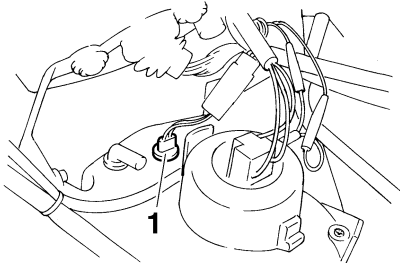

1. Auxiliary light bulb socket
3. Remove the defective bulb by pulling it out.
4. Insert a new bulb into the socket.
5. Install the auxiliary light socket (together with the bulb) by pushing it in.
6. Install the cowling together with the headlight unit.

## Supporting the motorcycle

EAU24350

Since this model is not equipped with a centerstand, follow these precautions when removing the front and rear wheel or performing other maintenance requiring the motorcycle to stand upright. Check that the motorcycle is in a stable and level position before starting any maintenance. A strong wooden box can be placed under the engine for added stability.

### To service the front wheel

1. Stabilize the rear of the motorcycle by using a motorcycle stand or, if an additional motorcycle stand is not available, by placing a jack under the frame in front of the rear wheel.
2. Raise the front wheel off the ground by using a motorcycle stand.

### To service the rear wheel

Raise the rear wheel off the ground by using a motorcycle stand or, if a motorcycle stand is not available, by placing

a jack either under each side of the frame in front of the rear wheel or under each side of the swingarm.

# PERIODIC MAINTENANCE AND MINOR REPAIR

## Front wheel

EAU24360

### XT660X

EAM1761

EWA10820

### To remove the front wheel

#### **WARNING**

- It is advisable to have a Yamaha dealer service the wheel.
- Securely support the motorcycle so that there is no danger of it falling over.

1. Loosen the front wheel axle pinch bolts, then the wheel axle and the brake caliper bolts.

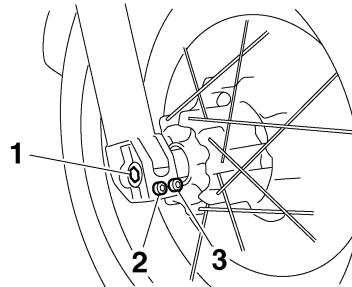

1. Wheel axle
2. Front wheel axle pinch bolt A
3. Front wheel axle pinch bolt B

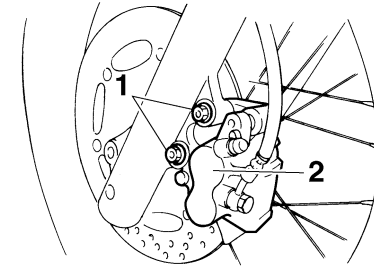

1. Bolt
2. Brake caliper

ECA11070

#### **CAUTION:**

**Do not apply the brake after the wheel has been removed together with the brake disc, otherwise the brake pads will be forced shut.**

4. Pull the wheel axle out, and then remove the wheel.

EAM1811

### To install the front wheel

1. Lift the wheel up between the fork legs.
2. Insert the wheel axle.
3. Lower the front wheel so that it is on the ground.

6

### XT660R

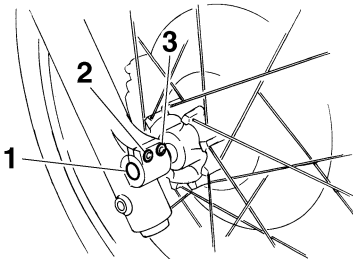

1. Wheel axle
2. Front wheel axle pinch bolt A
3. Front wheel axle pinch bolt B

# PERIODIC MAINTENANCE AND MINOR REPAIR

4. Install the brake caliper by installing the bolts.

**NOTE:** \_\_\_\_\_  
Make sure that there is enough space between the brake pads before installing the brake caliper onto the brake disc.

5. Tighten the wheel axle to the specified torque.
6. Tighten the wheel axle pinch bolt A and pinch bolt B to the specified torques.
7. Retighten the wheel axle pinch bolt A to the specified torque.
8. Tighten the brake caliper bolts to the specified torques.

## Tightening torques:

Wheel axle:

59 Nm (5.9 m·kgf, 43 ft·lbf)

Front wheel axle pinch bolt:

18 Nm (1.8 m·kgf, 13 ft·lbf)

Brake caliper bolt:

40 Nm (4.0 m·kgf, 29 ft·lbf)

9. Push down hard on the handlebar several times to check for proper fork operation.

## Rear wheel

EAU25080

XT660X

### To remove the rear wheel

EAUM1773

EWA10820

#### **WARNING**

- It is advisable to have a Yamaha dealer service the wheel.
- Securely support the motorcycle so that there is no danger of it falling over.

1. Remove the drive chain guard by removing the bolts.

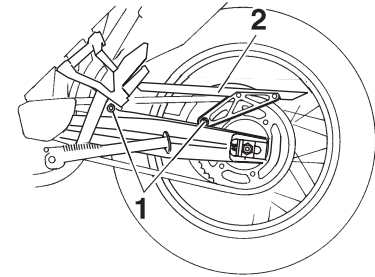

1. Bolt

2. Drive chain guard

2. Loosen the axle nut.

## XT660R

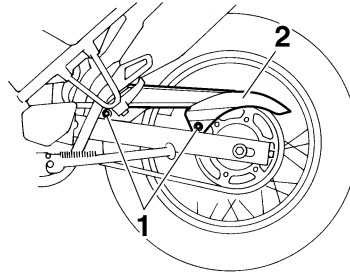

1. Bolt

2. Drive chain guard

## XT660R

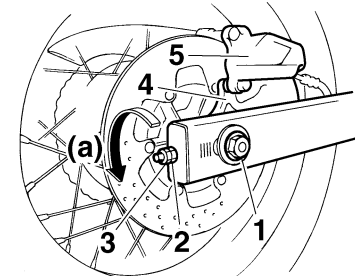

1. Axle nut

2. Drive chain slack adjusting nut

3. Locknut

4. Brake caliper bracket

5. Brake caliper

# PERIODIC MAINTENANCE AND MINOR REPAIR

## XT660X

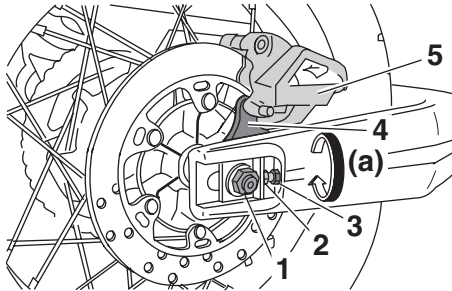

1. Axle nut
  2. Drive chain slack adjusting bolt
  3. Locknut
  4. Brake caliper bracket
  5. Brake caliper
3. Lift the rear wheel off the ground according to the procedure on page 6-35.
  4. Loosen the locknut on each side of the swingarm.
  5. Turn the drive chain slack adjusting nuts (or bolts according to the model) fully in direction (a).
  6. Remove the wheel axle by removing the axle nut.
  7. Push the wheel forward, and then remove the drive chain from the rear sprocket.

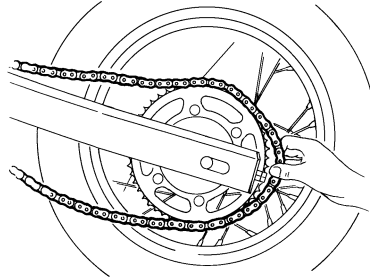

**NOTE:** \_\_\_\_\_  
The drive chain cannot be disassembled.

8. Pull the wheel backward and move the brake caliper away from the wheel.

ECA11070

**CAUTION:** \_\_\_\_\_  
**Do not apply the brake after the wheel has been removed together with the brake disc, otherwise the brake pads will be forced shut.**

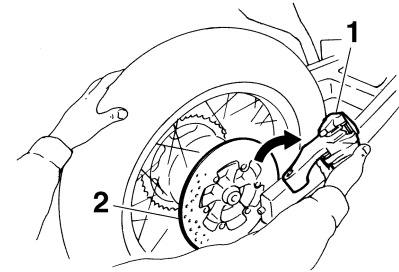

1. Brake caliper
2. Brake disc

EAM2140

### To install the rear wheel

1. Install the drive chain onto the rear sprocket.
2. Install the wheel, the washer(s) and the brake caliper bracket by inserting the wheel axle from the left-hand side.

**NOTE:** \_\_\_\_\_

- XT660R: Install the washer with the “N” mark on the right-hand side and the washer with the “O” mark on the left-hand side. Be sure to install both washers with their marks facing outward.

# PERIODIC MAINTENANCE AND MINOR REPAIR

EAU25870

- XT660X: Install the washer on the right-hand side.
- Make sure that the retainer on the swingarm is inserted into the slot in the brake caliper bracket.
- Make sure that there is enough space between the brake pads before installing the wheel.

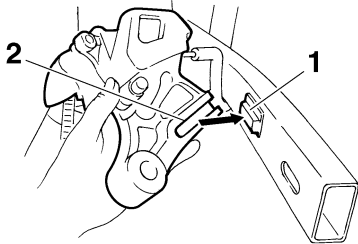

1. Retainer
2. Slot

3. Lower the rear wheel so that it is on the ground.
4. Adjust the drive chain slack. (See page 6-24.)
5. Tighten the axle nut to the specified torque.

## Tightening torque:

Locknut:

16 Nm (1.6 m·kgf, 11 ft·lbf)

Axle nut:

104 Nm (10.4 m·kgf, 75 ft·lbf)

6. Install the drive chain guard by installing the bolts.

## Troubleshooting

Although Yamaha motorcycles receive a thorough inspection before shipment from the factory, trouble may occur during operation. Any problem in the fuel, compression, or ignition systems, for example, can cause poor starting and loss of power.

The following troubleshooting charts represent quick and easy procedures for checking these vital systems yourself. However, should your motorcycle require any repair, take it to a Yamaha dealer, whose skilled technicians have the necessary tools, experience, and know-how to service the motorcycle properly.

Use only genuine Yamaha replacement parts. Imitation parts may look like Yamaha parts, but they are often inferior, have a shorter service life and can lead to expensive repair bills.

# PERIODIC MAINTENANCE AND MINOR REPAIR

EAU25921

## Troubleshooting charts

### Starting problems or poor engine performance

EWA10840



**WARNING**

Keep away open flames and do not smoke while checking or working on the fuel system.

#### 1. Fuel

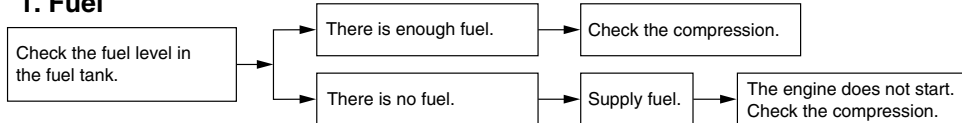

#### 2. Compression

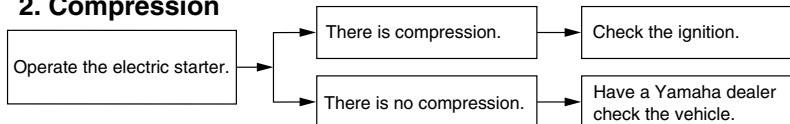

#### 3. Ignition

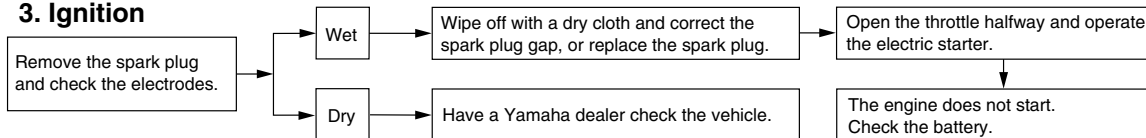

#### 4. Battery

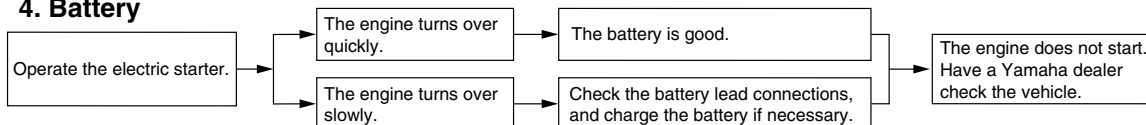

# PERIODIC MAINTENANCE AND MINOR REPAIR

## Engine overheating

EWA10400

### WARNING

- Do not remove the radiator cap when the engine and radiator are hot. Scalding hot fluid and steam may be blown out under pressure, which could cause serious injury. Be sure to wait until the engine has cooled.
- After removing the radiator cap retaining bolt, place a thick rag, like a towel, over the radiator cap, and then slowly rotate the cap counterclockwise to the detent to allow any residual pressure to escape. When the hissing sound has stopped, press down on the cap while turning it counterclockwise, and then remove the cap.

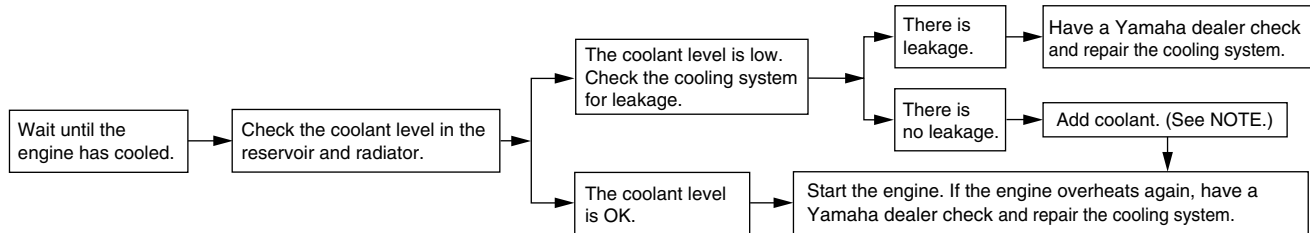

### NOTE:

If coolant is not available, tap water can be temporarily used instead, provided that it is changed to the recommended coolant as soon as possible.

# MOTORCYCLE CARE AND STORAGE

---

EAU26001

## Care

While the open design of a motorcycle reveals the attractiveness of the technology, it also makes it more vulnerable. Rust and corrosion can develop even if high-quality components are used. A rusty exhaust pipe may go unnoticed on a car, however, it detracts from the overall appearance of a motorcycle. Frequent and proper care does not only comply with the terms of the warranty, but it will also keep your motorcycle looking good, extend its life and optimize its performance.

## Before cleaning

1. Cover the muffler outlet with a plastic bag after the engine has cooled down.
2. Make sure that all caps and covers as well as all electrical couplers and connectors, including the spark plug cap, are tightly installed.
3. Remove extremely stubborn dirt, like oil burnt onto the crankcase, with a degreasing agent and a brush, but never apply such prod-

ucts onto seals, gaskets, sprockets, the drive chain and wheel axles. Always rinse the dirt and degreaser off with water.

## Cleaning

ECA10770

### CAUTION:

- **Avoid using strong acidic wheel cleaners, especially on spoked wheels. If such products are used on hard-to-remove dirt, do not leave the cleaner on the affected area any longer than instructed. Also, thoroughly rinse the area off with water, immediately dry it, and then apply a corrosion protection spray.**
- **Improper cleaning can damage windshields, cowlings, panels and other plastic parts. Use only a soft, clean cloth or sponge with mild detergent and water to clean plastic.**
- **Do not use any harsh chemical products on plastic parts. Be sure to avoid using cloths or sponges which have been in contact with strong or abrasive**

cleaning products, solvent or thinner, fuel (gasoline), rust removers or inhibitors, brake fluid, antifreeze or electrolyte.

- **Do not use high-pressure washers or steam-jet cleaners since they cause water seepage and deterioration in the following areas: seals (of wheel and swing-arm bearings, fork and brakes), electric components (couplers, connectors, instruments, switches and lights), breather hoses and vents.**
- **For motorcycles equipped with a windshield: Do not use strong cleaners or hard sponges as they will cause dulling or scratching. Some cleaning compounds for plastic may leave scratches on the windshield. Test the product on a small hidden part of the windshield to make sure that it does not leave any marks. If the windshield is scratched, use a quality plastic polishing compound after washing.**



# MOTORCYCLE CARE AND STORAGE

## After normal use

Remove dirt with warm water, a mild detergent, and a soft, clean sponge, and then rinse thoroughly with clean water. Use a toothbrush or bottlebrush for hard-to-reach areas. Stubborn dirt and insects will come off more easily if the area is covered with a wet cloth for a few minutes before cleaning.

## After riding in the rain, near the sea or on salt-sprayed roads

Since sea salt or salt sprayed on roads during winter are extremely corrosive in combination with water, carry out the following steps after each ride in the rain, near the sea or on salt-sprayed roads.

## **NOTE:** \_\_\_\_\_

Salt sprayed on roads in the winter may remain well into spring.

1. Clean the motorcycle with cold water and a mild detergent, after the engine has cooled down.

## **CAUTION:** \_\_\_\_\_

**Do not use warm water since it increases the corrosive action of the salt.**

2. Apply a corrosion protection spray on all metal, including chrome- and nickel-plated, surfaces to prevent corrosion.

## **After cleaning**

1. Dry the motorcycle with a chamois or an absorbing cloth.
2. Immediately dry the drive chain and lubricate it to prevent it from rusting.
3. Use a chrome polish to shine chrome, aluminum and stainless-steel parts, including the exhaust system. (Even the thermally induced discoloring of stainless-steel exhaust systems can be removed through polishing.)
4. To prevent corrosion, it is recommended to apply a corrosion protection spray on all metal, including chrome- and nickel-plated, surfaces.

ECA10790

5. Use spray oil as a universal cleaner to remove any remaining dirt.
6. Touch up minor paint damage caused by stones, etc.
7. Wax all painted surfaces.
8. Let the motorcycle dry completely before storing or covering it.

EWA11130

## **! WARNING** \_\_\_\_\_

- **Make sure that there is no oil or wax on the brakes or tires.**
- **If necessary, clean the brake discs and brake linings with a regular brake disc cleaner or acetone, and wash the tires with warm water and a mild detergent. Before riding at higher speeds, test the motorcycle's braking performance and cornering behavior.**

ECA10800

## **CAUTION:** \_\_\_\_\_

- **Apply spray oil and wax sparingly and make sure to wipe off any excess.**

# MOTORCYCLE CARE AND STORAGE

---

- Never apply oil or wax to any rubber and plastic parts, but treat them with a suitable care product.
  - Avoid using abrasive polishing compounds as they will wear away the paint.
- 

**NOTE:** \_\_\_\_\_

Consult a Yamaha dealer for advice on what products to use.

---

## Storage

EAM1900

### Short-term

Always store your motorcycle in a cool, dry place and, if necessary, protect it against dust with a porous cover.

ECA10810

### CAUTION:

- Storing the motorcycle in a poorly ventilated room or covering it with a tarp, while it is still wet, will allow water and humidity to seep in and cause rust.
  - To prevent corrosion, avoid damp cellars, stables (because of the presence of ammonia) and areas where strong chemicals are stored.
- 

### Long-term

Before storing your motorcycle for several months:

1. Follow all the instructions in the “Care” section of this chapter.
2. Fill up the fuel tank and add fuel stabilizer (if available) to prevent the fuel tank from rusting and the fuel from deteriorating.

3. Perform the following steps to protect the cylinder, piston rings, etc. from corrosion.
  - a. Remove the spark plug cap and spark plug.
  - b. Pour a teaspoonful of engine oil into the spark plug bore.
  - c. Install the spark plug cap onto the spark plug, and then place the spark plug on the cylinder head so that the electrodes are grounded. (This will limit sparking during the next step.)
  - d. Turn the engine over several times with the starter. (This will coat the cylinder wall with oil.)
  - e. Remove the spark plug cap from the spark plug, and then install the spark plug and the spark plug cap.

EWA10950

### **WARNING**

**To prevent damage or injury from sparking, make sure to ground the spark plug electrodes while turning the engine over.**

---

4. Lubricate all control cables and the pivoting points of all levers and pedals as well as of the side-stand/centerstand.
5. Check and, if necessary, correct the tire air pressure, and then lift the motorcycle so that both of its wheels are off the ground. Alternatively, turn the wheels a little every month in order to prevent the tires from becoming degraded in one spot.
6. Cover the muffler outlets with plastic bags to prevent moisture from entering them.
7. Remove the battery and fully charge it. Store it in a cool, dry place and charge it once a month. Do not store the battery in an excessively cold or warm place [less than 0 °C (30 °F) or more than 30 °C (90 °F)]. For more information on storing the battery, see page 6-30.

**NOTE:** \_\_\_\_\_  
Make any necessary repairs before storing the motorcycle.

---

# SPECIFICATIONS

## Dimensions:

Overall length:

XT660R 2240 mm (88.2 in)

XT660X 2175 mm (85.6 in)

Overall width:

XT660R 845 mm (33.3 in)

XT660X 860 mm (33.9 in)

Overall height:

XT660R 1230 mm (48.4 in)

XT660X 1170 mm (46.1 in)

Seat height:

XT660R 865 mm (34.1 in)

XT660X 875 mm (34.4 in)

Wheelbase:

XT660R 1505 mm (59.3 in)

XT660X 1490 mm (58.7 in)

Ground clearance:

XT660R 210 mm (8.27 in)

XT660X 205 mm (8.07 in)

Minimum turning radius:

2400 mm (94.5 in)

## Weight:

With oil and fuel:

XT660R 181.0 kg (399 lb)

XT660X 186.0 kg (410 lb)

## Engine:

Engine type:

Liquid cooled 4-stroke, SOHC

Cylinder arrangement:

Forward-inclined single cylinder

Displacement:

660.0 cm<sup>3</sup>

Bore × stroke:

100.0 × 84.0 mm (3.94 × 3.31 in)

Compression ratio:

10.00 :1

Starting system:

Electric starter

Lubrication system:

Dry sump

## Engine oil:

Type:

SAE10W30, SAE10W40, SAE15W40,  
SAE20W40 or SAE20W50

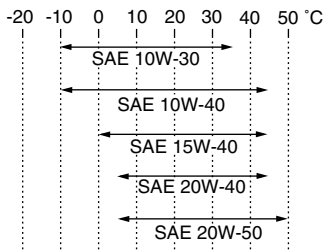

Recommended engine oil grade:

API service SE, SF, SG type or higher

Engine oil quantity:

Without oil filter element replacement:

2.50 L (2.64 US qt) (2.20 Imp.qt)

With oil filter element replacement:

2.60 L (2.75 US qt) (2.29 Imp.qt)

## Cooling system:

Coolant reservoir capacity (up to the maximum level mark):

0.25 L (0.26 US qt) (0.22 Imp.qt)

Radiator capacity (including all routes):

1.00 L (1.06 US qt) (0.88 Imp.qt)

## Air filter:

Air filter element:

Oil-coated paper element

## Fuel:

Recommended fuel:

Premium unleaded gasoline only

Fuel tank capacity:

15.0 L (3.96 US gal) (3.30 Imp.gal)

Fuel reserve amount:

5.0 L (1.32 US gal) (1.10 Imp.gal)

## Fuel injector:

Manufacturer:

DENSO

Model/quantity:

297500-0390

## Spark plug (s):

Manufacturer/model:

NGK/CR7E

Spark plug gap:

0.7–0.8 mm (0.028–0.031 in)

## Clutch:

Clutch type:

Wet, multiple-disc

## Transmission:

Primary reduction system:

Spur gear

Primary reduction ratio:

75/36 (2.083)

Secondary reduction system:

Chain drive

Secondary reduction ratio:

45/15 (3.000)

Transmission type:

Constant mesh 5-speed

# SPECIFICATIONS

Operation:  
Left foot operation

Gear ratio:

1st:  
30/12 (2.500)

2nd:  
26/16 (1.625)

3rd:  
23/20 (1.150)

4th:  
20/22 (0.909)

5th:  
20/26 (0.769)

**Chassis:**

Frame type:  
Diamond

Caster angle:  
XT660R 27.25 °  
XT660X 26.00 °

Trail:  
XT660R 107.0 mm (4.21 in)  
XT660X 94.0 mm (3.70 in)

## Front tire:

Type:  
With tube

Size:  
XT660R 90/90-21M/C 54S,  
90/90-21M/C 54T  
XT660X 120/70R17 M/C 58H,  
120/70ZR17 M/C 58W,  
120/70ZR17 M/C 58W

Manufacturer/model:  
XT660R METZELER/TOURANCE  
FRONT,  
MICHELIN/SIRAC  
XT660X PIRELLI/DRAGON,  
METZELER/SPORTEC M1,  
MICHELIN/RADIAL PILOT SPORT

## Rear tire:

Type:  
With tube

Size:  
XT660R 130/80-17M/C 65S,  
130/80-17M/C 65T  
XT660X 160/60R17 M/C 69H,  
160/60ZR17 M/C 69W,  
160/60ZR17 M/C 69W

Manufacturer/model:  
XT660R METZELER/TOURANCE,  
MICHELIN/SIRAC  
XT660X PIRELLI/DRAGON,  
METZELER/SPORTEC M1,  
MICHELIN/RADIAL PILOT SPORT

## Loading:

Maximum load:  
186 kg (410 lb)  
(Total weight of rider, passenger, cargo and accessories)

## Tire air pressure (measured on cold tires):

Loading condition:  
0–90 kg (0–198 lb)

Front:  
XT660R 200 kPa (29 psi) (2.00 kgf/cm<sup>2</sup>)  
XT660X 210 kPa (30 psi) (2.10 kgf/cm<sup>2</sup>)

Rear:  
XT660R 200 kPa (29 psi) (2.00 kgf/cm<sup>2</sup>)  
XT660X 210 kPa (30 psi) (2.10 kgf/cm<sup>2</sup>)

Loading condition:  
90–186 kg (198–410 lb)

Front:  
XT660R 200 kPa (29 psi) (2.00 kgf/cm<sup>2</sup>)  
XT660X 220 kPa (32 psi) (2.20 kgf/cm<sup>2</sup>)

Rear:  
XT660R 225 kPa (33 psi) (2.25 kgf/cm<sup>2</sup>)  
XT660X 230 kPa (33 psi) (2.30 kgf/cm<sup>2</sup>)

Off-road riding:

Front:  
XT660R 200 kPa (29 psi) (2.00 kgf/cm<sup>2</sup>)

Rear:  
XT660R 200 kPa (29 psi) (2.00 kgf/cm<sup>2</sup>)

## Front wheel:

Wheel type:  
Spoke wheel

Rim size:  
XT660R 21x1.85  
XT660X 17M/C x MT3.50

## Rear wheel:

Wheel type:  
Spoke wheel

Rim size:  
XT660R 17M/C x MT2.75  
XT660X 17M/C x MT4.25

## Front brake:

Type:  
Single disc brake

Operation:  
Right hand operation

# SPECIFICATIONS

---

Recommended fluid:  
DOT 4

## Rear brake:

Type:  
Single disc brake  
Operation:  
Right foot operation

Recommended fluid:  
DOT 4

## Front suspension:

Type:  
Telescopic fork  
Spring/shock absorber type:  
Coil spring/oil damper  
Wheel travel:  
XT660R 225.0 mm (8.86 in)  
XT660X 200.0 mm (7.87 in)

## Rear suspension:

Type:  
Swingarm (monocross)  
Spring/shock absorber type:  
Coil spring/gas-oil damper  
Wheel travel:  
XT660R 200.0 mm (7.87 in)  
XT660X 191.0 mm (7.52 in)

## Electrical system:

Ignition system:  
Transistorized coil ignition (digital)  
Charging system:  
AC magneto

## Battery:

Model:  
GT9B-4

Voltage, capacity:  
12 V, 8.0 Ah

## Headlight:

Bulb type:  
Halogen bulb

## Bulb voltage, wattage × quantity:

Headlight:  
12 V, 55 W/60.0 W × 1  
Tail/brake light:  
12 V, 5.0 W/21.0 W × 1  
Front turn signal light:  
12 V, 10.0 W × 2  
Rear turn signal light:  
12 V, 10.0 W × 2  
Auxiliary light:  
12 V, 5.0 W × 1  
Meter lighting:  
EL

Neutral indicator light:  
LED  
High beam indicator light:  
LED  
Turn signal indicator light:  
LED  
Fuel level warning light:  
LED  
Coolant temperature warning light:  
LED  
Engine trouble warning light:  
LED  
Immobilizer system indicator light:  
LED

## Fuses:

Main fuse:  
30.0 A  
Headlight fuse:  
20.0 A  
Signaling system fuse:  
10.0 A  
Ignition fuse:  
10.0 A  
Parking lighting fuse:  
10.0 A  
Radiator fan fuse:  
7.5 A  
Fuel injection system fuse:  
10.0 A  
Backup fuse:  
10.0 A

EAU26351

## Identification numbers

Record the key identification number, vehicle identification number and model label information in the spaces provided below for assistance when ordering spare parts from a Yamaha dealer or for reference in case the vehicle is stolen.

KEY IDENTIFICATION NUMBER:

VEHICLE IDENTIFICATION NUMBER:

MODEL LABEL INFORMATION:

## Key identification number

EAU26381

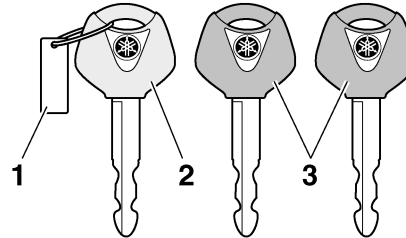

1. Key identification number
2. Code re-registering key (red bow)
3. Standard keys (black bow)

The key identification number is stamped into the key tag. Record this number in the space provided and use it for reference when ordering a new key.

## Vehicle identification number

EAU26410

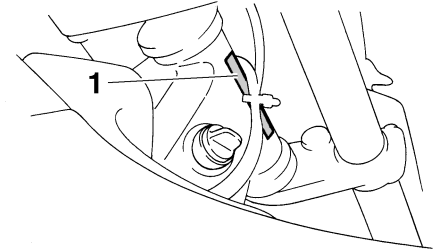

1. Vehicle identification number

The vehicle identification number is stamped into the frame.

**NOTE:** \_\_\_\_\_  
The vehicle identification number is used to identify your vehicle and may be used to register it with the licensing authority in your area.  
\_\_\_\_\_

# CONSUMER INFORMATION

---

EAU26540

## Model label

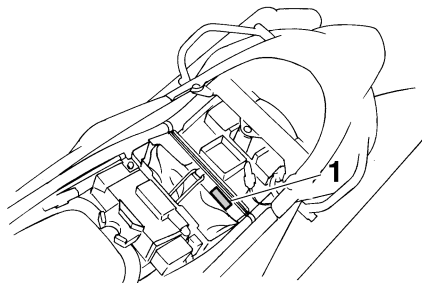

### 1. Model label

The model label is affixed to the frame under the seat. (See page 3-12.) Record the information on this label in the space provided. This information will be needed when ordering spare parts from a Yamaha dealer.



- A**
- Air filter element and check hose,
    - replacing and cleaning ..... 6-16
  - Anti-theft alarm (optional) ..... 3-7
  - Auxiliary light bulb, replacing ..... 6-35
- B**
- Battery ..... 6-30
  - Brake and clutch levers, checking and
    - lubricating ..... 6-27
  - Brake fluid level, checking ..... 6-23
  - Brake lever ..... 3-9
  - Brake pedal ..... 3-10
  - Brake pedal, lubricating ..... 6-28
- C**
- Cables, checking and lubricating ..... 6-27
  - Care ..... 7-1
  - Catalytic converter ..... 3-12
  - Clutch lever ..... 3-9
  - Clutch lever free play, adjusting ..... 6-21
  - Coolant ..... 6-13
  - Coolant temperature warning light ..... 3-4
  - Cowlings and panels, removing and
    - installing ..... 6-5
- D**
- Dimmer switch ..... 3-8
  - Drive chain, cleaning and lubricating .... 6-26
  - Drive chain slack ..... 6-24
- E**
- Engine break-in ..... 5-3
  - Engine idling speed ..... 6-17
  - Engine oil and oil filter element ..... 6-10
  - Engine stop switch ..... 3-8
  - Engine trouble warning light ..... 3-4
- F**
- Front and rear brake pads, checking ....6-22
  - Front fork, checking .....6-29
  - Fuel .....3-11
  - Fuel consumption, tips for reducing .....5-3
  - Fuel level warning light .....3-4
  - Fuel tank cap .....3-10
  - Fuses, replacing .....6-32
- H**
- Handlebar switches .....3-7
  - Hazard switch .....3-8
  - Headlight bulb, replacing .....6-33
  - High beam indicator light .....3-4
  - Horn switch .....3-8
- I**
- Identification numbers .....9-1
  - Ignition circuit cut-off system .....3-15
  - Immobilizer system .....3-1
  - Immobilizer system indicator light .....3-4
  - Indicator and warning lights .....3-3
- K**
- Key identification number .....9-1
- M**
- Main switch/steering lock .....3-2
  - Model label .....9-2
  - Multi-function display .....3-5
- N**
- Neutral indicator light .....3-3
- P**
- Parking .....5-4
  - Part locations .....2-1
  - Pass switch .....3-8
  - Periodic maintenance and lubrication
    - chart .....6-2
  - Pre-operation check list ..... 4-2
- R**
- Rear brake light switch, adjusting ..... 6-22
- S**
- Safety information ..... 1-1
  - Seat ..... 3-12
  - Shifting ..... 5-2
  - Shift pedal ..... 3-9
  - Shock absorber assembly, adjusting .... 3-13
  - Sidestand ..... 3-14
  - Sidestand, checking and lubricating .... 6-28
  - Spark plug, checking ..... 6-9
  - Specifications ..... 8-1
  - Starting the engine ..... 5-1
  - Start switch ..... 3-8
  - Steering, checking ..... 6-29
  - Storage ..... 7-3
  - Storage compartment ..... 3-13
  - Supporting the motorcycle ..... 6-35
- T**
- Throttle cable free play, checking ..... 6-18
  - Throttle grip and cable, checking and
    - lubricating ..... 6-27
  - Tires ..... 6-18
  - Tool kit ..... 6-1
  - Troubleshooting ..... 6-39
  - Troubleshooting charts ..... 6-40
  - Turn signal indicator light ..... 3-3
  - Turn signal light bulb or tail/brake light
    - bulb, replacing ..... 6-34
  - Turn signal switch ..... 3-8
- V**
- Vehicle identification number ..... 9-1

# INDEX

---

## W

Wheel bearings, checking.....	6-30
Wheel (front) .....	6-36
Wheel (rear) .....	6-37
Wheels .....	6-21





PRINTED IN FRANCE  
2006.07 (E)